

# Platform Cylinder

## CXT Series

ø12, ø16, ø20, ø25, ø32, ø40

A highly rigid and highly accurate slide table integrated with an actuator.

- Two types of guide rod bearings to accommodate your application
  - Slide bearing — For heavy loads
  - Ball bushing bearing — For highly accurate and smooth operation

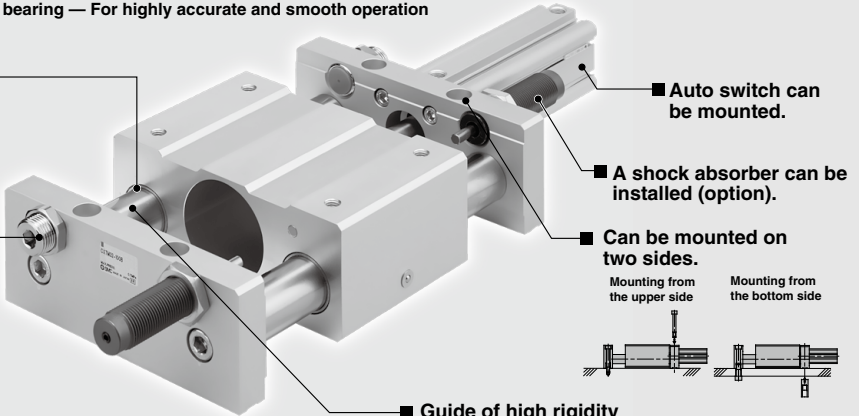

- Adjusting bolt with bumper is standard.
  - Performs the function of a cushion and adjusts the stroke 5 mm on each side, or 10 mm for both sides.

For moving and transferring workpieces.

For moving the receptacle for workpieces used in stamping or press-fitting processes.

For using as a Pick & Place unit in combination with other actuators.

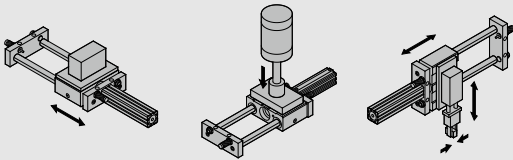

Series	Maximum load weight (kg)	CXTM (Slide bearing)		CXTL (Ball bushing bearing)	
		Table <sup>(1)</sup> displacement (mm)	Allowable <sup>(2)</sup> static mass (kg)	Table <sup>(1)</sup> displacement (mm)	Allowable <sup>(2)</sup> static mass (kg)
CXT□12	3	0.002	350	0.015	60
CXT□16	7	0.004	500	0.019	70
CXT□20	12	0.007	900	0.044	125
CXT□25	20	0.030	900	0.180	125
CXT□32	30	0.032	1100	0.123	140
CXT□40	50	0.025	1900	0.109	170

Note 1) Table displacement

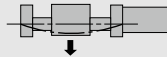

"Table displacement" is the amount of deflection of the guide rod that occurs when a maximum load weight is placed on the maximum stroke table while the table is at the center of the stroke (the amount of looseness is not included).

Note 2) Allowable static weight

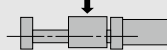

An "allowable static mass" is the allowable amount of static mass that can be applied vertically to the workpiece mounting surface of the table while the table is at the stroke end.

### Series Variations

Bearing type		Bore size (mm)	Stroke (mm)											
Slide bearing	Ball bushing bearing		15	25	50	75	100	125	150	175	200	250	300	
CXTM12	CXTL12	12	●	●	○	○	○	○	○	○	○	○	○	
CXTM16	CXTL16		16	●	●	○	○	○	○	○	○	○	○	
CXTM20	CXTL20	20	●	●	○	○	○	○	○	○	○	○	○	
CXTM25	CXTL25		25	●	●	○	○	○	○	○	○	○	○	
CXTM32	CXTL32	32	●	●	○	○	○	○	○	○	○	○	○	
CXTM40	CXTL40		40	●	●	○	○	○	○	○	○	○	○	

●.....Standard stroke ○.....Long stroke

# CXT Series Model Selection

## Selection Step

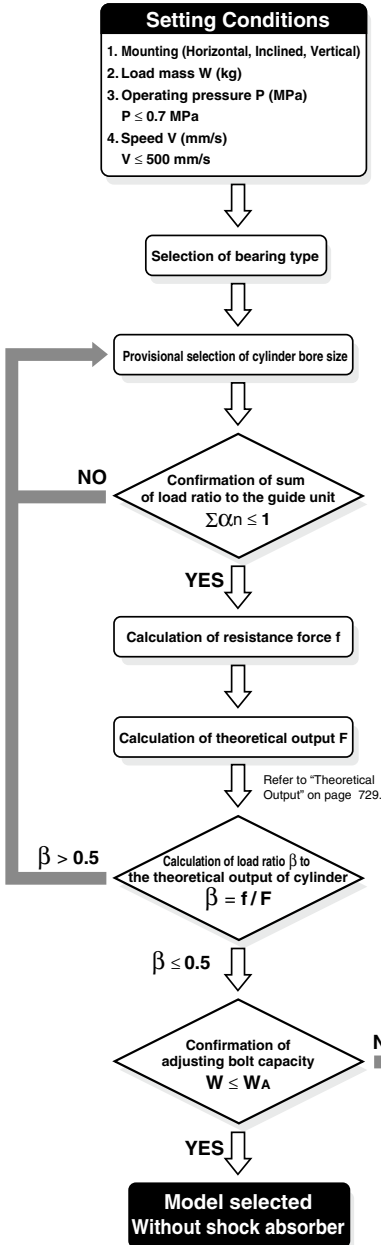

### Guideline for Selection of Bearing Type

Bearing type	Required conditions
Slide bearing	<ul style="list-style-type: none"> <li>• Impact load and vibration load are added.</li> <li>• Change in load is large.</li> <li>• Long life span is required.</li> </ul>
Ball bushing bearing	<ul style="list-style-type: none"> <li>• High accuracy (Little rattle is allowed.)</li> <li>• Smooth operation</li> </ul>

$$\sum \alpha n = \frac{\text{Load mass [W]}}{\text{Maximum load mass [Wmax]}} + \frac{\text{Moment [mN]}}{\text{Allowable moment [Mn]}}$$

Load mass [W] are as follows in compliance to the mounting way.

Horizontal mounting: W

Inclined mounting:  $W \cos \theta$  ( $\theta$ : Angle of inclination, refer to the figure below.)

Vertical mounting: 0 (None)

The moment rate must be calculated in accordance with the above formula for all types, **M1 to M3**.

As for **Wmax** and **Mn**, refer to the maximum load weight and allowable moment table in the next section.

The moment for the inclined mounting must be calculated taking the moment caused by the load into consideration.

Note) Make sure that the distance between the guide shaft center to the center of gravity of the load does not exceed the distance **GP** between the guide shafts given in the table below. If the distance must be exceeded due to unavoidable circumstances, decrease the load rate that is applied to the guide as indicated below in order to determine the distance.

$$\sum \alpha n \leq \frac{1}{(L/GP)^2} \quad (\text{Provided that } L > GP)$$

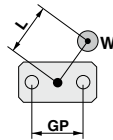

Bore size	12	16	20	25	32	40
Distance between guide rods GP (mm)	50	65	80	90	110	130

Horizontal mounting:  $f = \mu \times W$   
 Inclined mounting:  $f = \mu \times W \cos \theta + W \sin \theta$   
 (Refer to the figure on the right.)  
 Vertical mounting:  $f = W$   
 $\mu = 0.3$  (Slide bearing)  
 $\mu = 0.1$  (Ball bushing bearing)

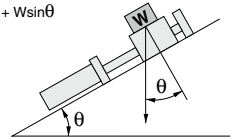

NO

Determine the movable weight **W<sub>A</sub>** which can be operated only by adjusting bolts.

## Non-rotating Accuracy of Slide Block

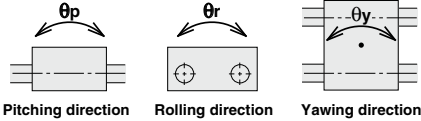

Bore size (mm)	CXTM (Slide bearing)		CXTL (Ball bushing bearing)	
	$\theta_p (= \theta_y)$	$\theta_r$	$\theta_p (= \theta_y)$	$\theta_r$
12	$\pm 0.09^\circ$	$\pm 0.12^\circ$	$\pm 0.05^\circ$	$\pm 0.05^\circ$
16	$\pm 0.08^\circ$	$\pm 0.10^\circ$	$\pm 0.05^\circ$	$\pm 0.04^\circ$
20	$\pm 0.07^\circ$	$\pm 0.08^\circ$	$\pm 0.04^\circ$	$\pm 0.03^\circ$
25	$\pm 0.07^\circ$	$\pm 0.07^\circ$	$\pm 0.04^\circ$	$\pm 0.03^\circ$
32	$\pm 0.08^\circ$	$\pm 0.07^\circ$	$\pm 0.04^\circ$	$\pm 0.03^\circ$
40	$\pm 0.06^\circ$	$\pm 0.06^\circ$	$\pm 0.03^\circ$	$\pm 0.03^\circ$

## Maximum Load Mass and Allowable Moment

Bore size (mm)	Bearing	Maximum load mass $W_{max}$ (kg)	Allowable moment (N·m)	
			M1 (= M3)	M2
12	Slide bearing	3	1.25	1.68
	Ball bushing bearing		0.53	0.70
16	Slide bearing	7	3.34	4.25
	Ball bushing bearing		1.53	2.11
20	Slide bearing	12	11.4	17.1
	Ball bushing bearing		5.60	7.28
25	Slide bearing	20	11.4	19.3
	Ball bushing bearing		5.60	8.19
32	Slide bearing	30	19.8	23.3
	Ball bushing bearing		10.1	14.8
40	Slide bearing	50	37.3	46.2
	Ball bushing bearing		21.3	27.5

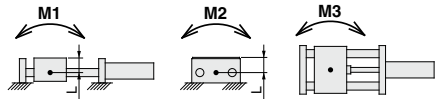

Note) For the purpose of calculating the moment, the length of the arm is the distance that is measured from the guide shaft center (● mark). Dimension L from the guide shaft center to the top surface of the table is indicated below.

Bore size	12	16	20	25	32	40
L dimension	19.5	24	28	31	39.5	47.5

## Allowable Load Only by Adjustment Bolt

If only the adjustment bolt is used for stopping the load, make sure that the load weight and the speed will be below the curve in the graph on the right, taking into consideration the durability of the rubber bumper that is attached to the end of the adjustment bolt and the vibration and noise that are created when stopping (provided that the maximum load weight is not exceeded).

In conditions in which the load weight and the speed will be above the curve, use a shock absorber (provided that the maximum load weight not exceeded).

### ⚠ Caution

In the case of the ball bushing type, the service life could be drastically shortened if shocks or excessive moments are applied. Therefore, even if the conditions given above are not exceeded, the use of a shock absorber is recommended.

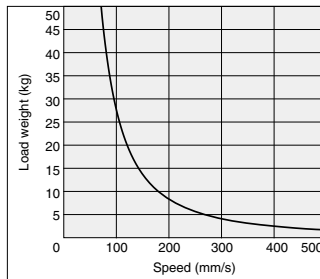

## Static Movable Mass when Stopped

When the CXT series cylinder is used for moving the workpiece receptacle, such as in a stamping or press-fitting process, a vertical load will be applied to the top surface of the stopped slide block (refer to the figure on the right). In this case, the allowable mass is greater than the maximum load weight, as given in the table on the right.

### ⚠ Caution

1. Make sure that the slide block is stopped at the stroke end.
2. Match the center of the mass to be applied with the center of the slide block. The direction of the mass must be vertically downward in relation to the surface on which the workpiece is mounted, as shown in the figure on the right.
3. Do not apply a load that involves shocks such as those caused by pounding (particularly with the ball bushing type).
4. If this mass is applied, the deflection of the guide shaft will also have a large value.

### Allowable Static Mass (kg)

Bore size (mm)	CXTM (Slide bearing)	CXTL (Ball bushing bearing)
12	350	60
16	500	70
20	900	125
25	900	125
32	1100	140
40	1900	170

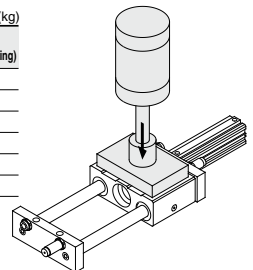

# Platform Cylinder CXT Series

ø12, ø16, ø20, ø25, ø32, ø40

## How to Order

**Port thread type**

Nil	M thread	ø12 to ø25
	Rc	
TN	NPT	ø32, ø40
TF	G	

**CXT M 20 - 100 B - M9BW**

**Platform cylinder**

**Bearing type**

M	Slide bearing
L	Ball bushing bearing

**Bore size/Stroke (mm)**

Bore size (mm)	Stroke (mm)									
	15	25	50	75	100	125	150	175	200	300
12	●	●	○	○	○	○	○	○	○	○
16	●	●	○	○	○	○	○	○	○	○
20	●	●	○	○	○	○	○	○	○	○
25	●	●	○	○	○	○	○	○	○	○
32	●	●	○	○	○	○	○	○	○	○
40	●	●	○	○	○	○	○	○	○	○

●.....Standard stroke ○.....Long stroke

**Auto switch**

Nil	Without auto switch (Built-in magnet)
-----	---------------------------------------

**Made to Order**  
Refer to page 729 for details.

**Number of auto switches**

Nil	2 pcs.
S	1 pc.
n	"n" pcs.

**Option**

Nil	Adjusting bolt with bumper only (Standard)
B	With 2 shock absorbers (Set on the driving cylinder side only when packed.)
BS	With 1 shock absorber (Set on the driving cylinder side when packed.)

## Shock Absorbers

Type	Bore size (mm)			
	12, 16	20	25	32, 40
Standard (shock absorber RB series)	RB0806	RB1007	RB1411	RB2015
Shock absorber soft type RJ series type (-XB22)	RJ0806H	RJ1007H	RJ1412H	—

- \* The shock absorber service life is different from that of the CXT cylinder. Refer to the **Web Catalog** for each shock absorber for the replacement period.
- \* The shock absorber soft type RJ series type (-XB22) is a made to order specification. For details, refer to page 1468.

\* For minimum strokes for auto switch equipped type, refer to page 734.

## Applicable Auto Switches/Refer to pages 1289 to 1383 for further information on auto switches.

Type	Special function	Electrical entry	Indicator light	Wiring (Output)	Load voltage		Auto switch part no.		Lead wire length					Pre-wired connector	Applicable load		
					DC	AC	Perpendicular	In-line	0.5 (Nil)	1 (M)	3 (L)	5 (Z)	None (N)				
									●	●	●	○				—	○
Solid state auto switch	—	Grommet	Yes	3-wire (NPN)	24 V	—	M9NV	M9N	●	●	●	○	—	○	IC circuit		
				3-wire (PNP)					●	●	●	○	—	○			
				2-wire					●	●	●	○	—	○			
				3-wire (NPN)					●	●	●	○	—	○			
	Diagnostic indication (2-color indicator)			Grommet	Yes	3-wire (PNP)	24 V	—	M9PWW	M9PW	●	●	●	○	—	○	IC circuit
						2-wire					●	●	●	○	—	○	
						3-wire (PNP)					●	●	●	○	—	○	
						2-wire					●	●	●	○	—	○	
		3-wire (PNP)	●			●					●	○	—	○			
		2-wire	●			●					●	○	—	○			
Water resistant (2-color indicator)	Grommet	Yes	3-wire (PNP)	24 V	—	M9PAV*1	M9PA*1	○	○	○	●	—	○	IC circuit			
			2-wire					○	○	○	●	—	○				
Magnetic field resistant(2-color indicator)	Grommet	Yes	2-wire (Non-polar)	24 V	—	—	P3DWA	●	●	●	—	—	○	—			
			3-wire (NPN equivalent)					—	—	—	—	—	—		—	—	—
Reed auto switch	—	Grommet	No	2-wire	24 V	5 V, 12 V	A96V	A96	●	●	●	—	—	—	IC circuit		
									12 V	A93V*2	A93	●	●	●		—	—
									5 V, 12 V			A90V	A90	●		●	●
100 V or less	—	—	—	—	—	—	—	—	—	—	IC circuit						

\*1 Water resistant type auto switches can be mounted on the above models, but in such case SMC cannot guarantee water resistance. Consult with SMC regarding water resistant types with the above model numbers.

\*2 1 m type lead wire is only applicable to D-A93.

\* Lead wire length symbols: 0.5 m ..... Nil (Example) M9NW  
1 m ..... M (Example) M9NWM  
3 m ..... L (Example) M9NWL  
5 m ..... Z (Example) M9NWZ

\* Solid state auto switches marked with "○" are produced upon receipt of order.  
\* D-P3DWA□ is compatible with ø25 to ø40.

\* Since there are other applicable auto switches than listed, refer to page 736 for details.

\* For details about auto switches with pre-wired connector, refer to pages 1358 and 1359.

## Specifications

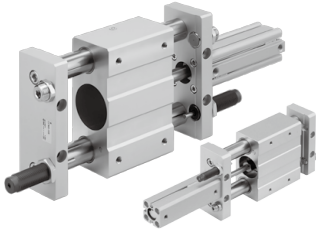

Bore size (mm)	12	16	20	25	32	40
Fluid	Air					
Action	Double acting					
Proof pressure	1.5 MPa					
Maximum operating pressure	0.7 MPa <sup>Note)</sup>					
Minimum operating pressure	0.15 MPa					
Ambient and fluid temperature	-10 to 60°C (No freezing)					
Piston speed	50 to 500 mm/s					
Cushion	Bumper (Both ends/Standard), Shock absorber (Option)					
Lubrication	Not required (Non-lube)					
Stroke adjusting range	-10 mm (Extension end, Retraction end: -5 mm each)					

Note) Maximum operating pressure for this product with the bumper feature.  
The maximum operating pressure for the cylinder alone is 1 MPa.

## Shock Absorber Specifications

For detailed specifications about shock absorber, refer to the [Web Catalog](#).

Model	CXT□ <sup>12</sup> <sub>16</sub>	CXT□20	CXT□25	CXT□ <sup>32</sup> <sub>40</sub>	
Shock absorber model	RB0806	RB1007	RB1411	RB2015	
Max. energy absorption (J)	2.94	5.88	14.7	58.8	
Stroke absorption (mm)	6	7	11	15	
Collision speed	0.05 to 5 m/s				
Max. operating frequency* (cycle/min)	80	70	45	25	
Ambient temperature	-10 to 80°C				
Spring force (N)	Extended	1.96	4.22	6.86	8.34
	Retracted	4.22	6.86	15.30	20.50
Weight (g)	15	25	65	150	

\* It denotes the values at the maximum energy absorption per one cycle. Therefore, the operating frequency can be increased according to the energy absorption.

The shock absorber service life is different from that of the CXT cylinder depending on the operating conditions. Refer to the [Web Catalog](#) for the replacement period.

## Theoretical Output

Bore size (mm)	Operating direction	Piston area (mm <sup>2</sup> )	Operating pressure (MPa)		
			0.3	0.5	0.7
12	IN	84.8	25	42	59
	OUT	113	34	57	79
16	IN	151	45	75	106
	OUT	201	60	101	141
20	IN	236	71	118	165
	OUT	314	94	157	220
25	IN	378	113	189	264
	OUT	491	147	245	344
32	IN	603	181	302	422
	OUT	804	241	402	563
40	IN	1056	317	528	739
	OUT	1257	377	628	880

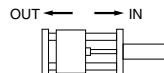

Made to Order

Made to Order: Individual Specifications  
(For details, refer to page 737.)

Symbol	Specifications
X138	Adjustable stroke type
X777	Fluororubber seals (Actuating cylinder unit only)

Made to Order

[Click here for details](#)

Symbol	Specifications
XB13	Low speed cylinder (5 to 50 mm/s)
XB22	Shock absorber soft type RJ series type

# CXT Series

## Weight

### CXTM (Slide bearing)

(kg)

Bore size (mm) \ Stroke (mm)	15	25	50	75	100	125	150	175	200	250	300
12	0.85 (0.35)	0.90 (0.35)	1.02 (0.35)	1.13 (0.36)	1.25 (0.37)	—	—	—	—	—	—
16	1.18 (0.50)	1.24 (0.50)	1.39 (0.51)	1.54 (0.52)	1.68 (0.53)	—	—	—	—	—	—
20	—	2.35 (0.85)	2.61 (0.87)	2.89 (0.88)	3.15 (0.90)	3.41 (0.91)	3.66 (0.93)	3.92 (0.94)	4.18 (0.96)	—	—
25	—	2.76 (1.09)	3.03 (1.11)	3.34 (1.14)	3.62 (1.16)	3.89 (1.18)	4.16 (1.21)	4.43 (1.23)	4.70 (1.25)	5.25 (1.30)	5.79 (1.34)
32	—	4.61 (2.06)	4.96 (2.10)	5.32 (2.14)	5.67 (2.17)	5.95 (2.21)	6.31 (2.25)	6.64 (2.29)	6.99 (2.33)	7.67 (2.41)	8.36 (2.49)
40	—	8.28 (3.71)	8.79 (3.75)	9.29 (3.79)	9.79 (3.83)	10.34 (3.87)	10.84 (3.91)	11.36 (3.95)	11.87 (3.99)	12.88 (4.07)	13.91 (4.15)

### CXTL (Ball bushing bearing)

(kg)

Bore size (mm) \ Stroke (mm)	15	25	50	75	100	125	150	175	200	250	300
12	0.75 (0.41)	0.78 (0.42)	0.85 (0.42)	0.92 (0.42)	0.98 (0.43)	—	—	—	—	—	—
16	1.05 (0.57)	1.08 (0.57)	1.18 (0.58)	1.27 (0.59)	1.35 (0.60)	—	—	—	—	—	—
20	—	2.00 (1.02)	2.15 (1.04)	2.32 (1.05)	2.46 (1.07)	2.60 (1.08)	2.75 (1.10)	2.89 (1.11)	3.03 (1.13)	—	—
25	—	2.41 (1.25)	2.57 (1.28)	2.77 (1.30)	2.92 (1.33)	3.08 (1.35)	3.24 (1.37)	3.40 (1.39)	3.56 (1.42)	3.78 (1.46)	4.19 (1.50)
32	—	4.22 (2.26)	4.45 (2.30)	4.69 (2.34)	4.92 (2.38)	5.08 (2.42)	5.32 (2.46)	5.54 (2.50)	5.77 (2.54)	6.21 (2.62)	6.66 (2.70)
40	—	7.53 (4.31)	7.83 (4.35)	8.13 (4.39)	8.42 (4.43)	8.76 (4.47)	9.06 (4.51)	9.37 (4.55)	9.67 (4.59)	10.27 (4.67)	10.88 (4.74)

Note 1) ( ): Denotes the values of the movable parts weight. (Movable parts weight of a cylinder is included, too.)

Note 2) The weight indicated above does not include a shock absorber.

## Series Applicable to Operating Environments that Do Not Accept Copper

### ● Copper/Fluorine-free specifications.....20- series

\* For details, refer to the SMC website.

**Construction**

**CXTM**  
Guide rod/bearing

**CXTL**  
Guide rod/bearing

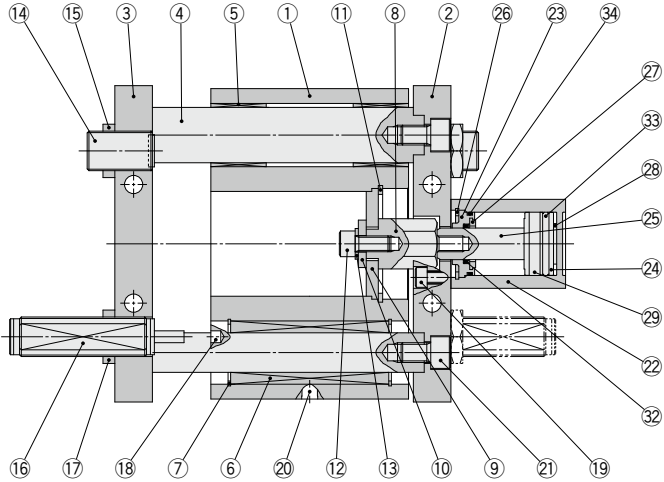

ø32

Long stroke

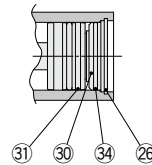
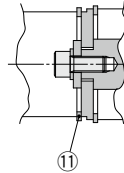

**Component Parts**

No.	Description	Material	Note
1	Slide block	Aluminum alloy	Anodized
2	Plate A	Aluminum alloy	Anodized
3	Plate B	Aluminum alloy	Anodized
4	Guide rod	Carbon steel	Hard chrome plating
5	Slide bearing	Bearing alloy	
6	Ball bushing bearing	—	
7	Type C retaining ring	Carbon tool steel	Phosphate coating
8	Adapter	Carbon steel	Electroless nickel plating
9	Connected disk	Carbon steel	Electroless nickel plating
10	Washer	Carbon steel	Zinc chromated
11	Type C retaining ring	Carbon tool steel	Phosphate coating
12	Hexagon socket head cap screw	Carbon steel	Zinc chromated
13	Spring washer	Steel wire	Zinc chromated
14	Adjusting bolt (With bumper)	Carbon steel, Urethane	Zinc chromated
15	Nut	Carbon steel	Zinc chromated
16	Shock absorber	—	Option
17	Nut	Carbon steel	Zinc chromated
18	Parallel pin	Carbon steel	

**Component Parts**

No.	Description	Material	Note
19	Hexagon socket head cap screw	Carbon steel	Zinc chromated
20	Grease nipple	—	ø16 to ø40   Nickel plating
21	Hexagon socket head cap screw	Carbon steel	Zinc chromated
22	Cylinder tube	Aluminum alloy	Hard anodized
23	Collar	Aluminum alloy	Anodized
24	Piston	Aluminum alloy	Chromated
25	Piston rod	Stainless steel	ø12 to ø25   —
		Carbon steel	ø32, ø40   Hard chrome plating
26	Type C retaining ring	Carbon tool steel	Phosphate coating
27	Bumper A	Urethane	
28	Bumper B	Urethane	
29	Magnet	—	
30	Bottom plate	Aluminum alloy	Anodized
31	Wear ring	Resin	
32	Rod seal	NBR	
33	Piston seal	NBR	
34	Tube gasket	NBR	

**Replacement Parts/Seal Kit**

Model Cylinder	Kit no.					
	CXT□12	CXT□16	CXT□20	CXT□25	CXT□32	CXT□40
Stroke	CDQSB12	CDQSB16	CDQSB20	CDQSB25	CDQ2A32	CDQ2A40
Standard stroke	CQSB12-PS	CQSB16-PS	CQSB20-PS	CQSB25-PS	CQ2B32-PS	CQ2B40-PS
Long stroke	CQSB12-L-PS	CQSB16-L-PS	CQSB20-L-PS	CQSB25-L-PS	CQ2A32-L-PS	CQ2A40-L-PS

\* Seal kit includes 32, 33 and 34. Order the seal kit with the kit number.

\* Since the seal kit does not include a grease pack, order it separately.

Grease pack part no.: GR-S-010 (10 g)

# CXT Series

Dimensions:  $\varnothing 12$  to  $\varnothing 25$

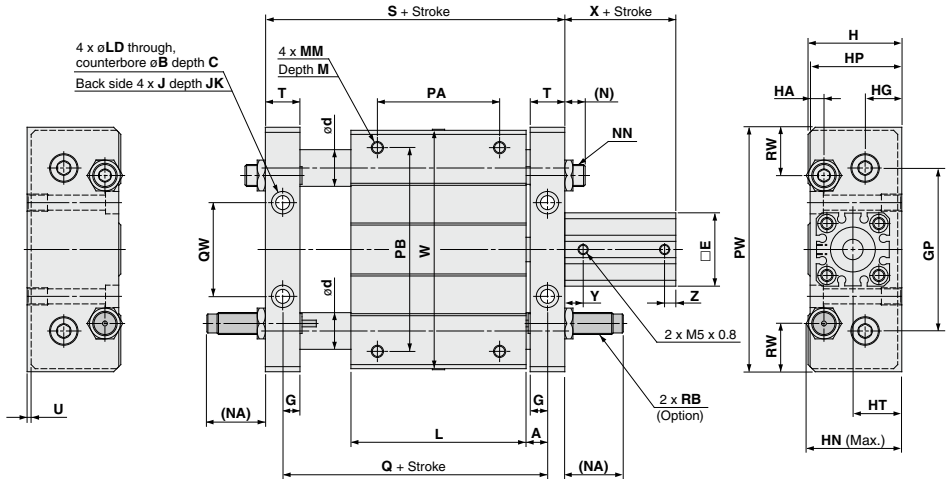

### Cylinder form

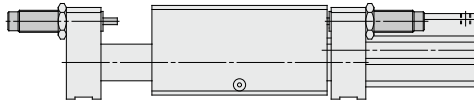

$\varnothing 12$



$\varnothing 16$

Bore size (mm)	Standard stroke (mm)	A	B	C	d		E	G	GP	H	HA	HG	HN	HP	HT	J	JK	L	LD
					Slide	Ball bushing													
12	15, 25	8.5	8	4	16	10	25	7.5	50	34	6	14.5	34	33	18	M5 x 0.8	9.5	68	4.3
16	15, 25	7.5	9.5	5	18	12	29	6.5	65	40	6.5	16	39.5	39	21	M6 x 1	9.5	75	5.2
20	25, 50	9.5	11	6.5	25	16	36	8.5	80	46	9	18	44.1	45	24	M8 x 1.25	10	86	6.9
25	25, 50	9.5	11	6.5	25	16	40	8.5	90	54	9	23	55	53	28	M8 x 1.25	10	86	6.9

Bore size (mm)	MM	M	(N)	(NA)	NN	PA*	PB	PW	Q	QW	RB	RW	S	T	U	W	X	Y	Z
12	M4 x 0.7	6	8	27	M8 x 1.0	30	60	80	85	26	RB0806	17.5	96	13	1	77	22	7.5	5
16	M5 x 0.8	8	8	27	M8 x 1.0	45	70	95	90	40	RB0806	15	103	13	2	92	22	7.5	5
20	M6 x 1	10	10	29	M10 x 1.0	60	100	120	105	46	RB1007	26	122	17	2	117	29.5	8	5.5
25	M6 x 1	10	12	50	M14 x 1.5	60	100	130	105	50	RB1411	22	122	17	2	127	32.5	9	5.5

\* PA dimension is the center sorted factor of the L dimension.

### Long Stroke

Bore size (mm)	Stroke range (mm)	(mm)		
		X	Y	Z
12	50, 75, 100	32	7.5	7.5
16	50, 75, 100	32	7.5	7.5
20	75, 100, 125, 150, 175, 200	41	8	8
25	75, 100, 125, 150, 175, 200, 250, 300	44	9	9



**Dimensions:  $\varnothing 32, \varnothing 40$**

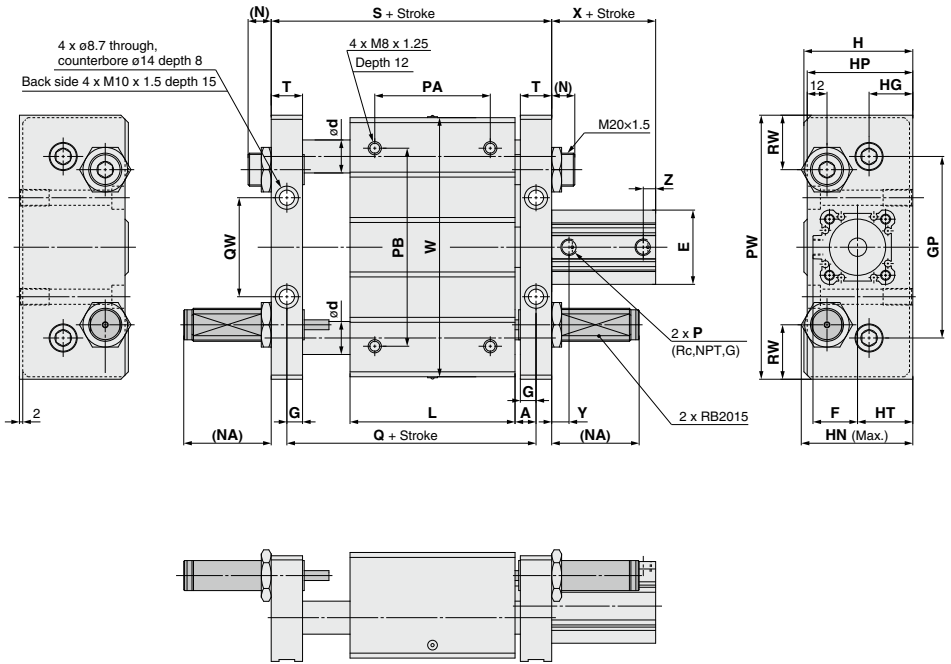

(mm)

Bore size (mm)	Standard stroke (mm)	A	d		E	F	G	GP	H	HG	HN	HP	HT	L	(N)	(NA)	P <sup>(Note)</sup>	PA <sup>*</sup>	PB	PW	Q
			Slide	Ball bushing																	
32	25, 50, 75, 100	10.5	28	20	45	27	9.5	110	66	26.5	67.6	64	33.5	100	14	53	1/8	70	120	160	121
40	25, 50, 75, 100	11.5	36	25	52	31	10.5	130	78	30.5	77.6	74	40.5	136	12	51	1/8	90	140	190	159

Bore size (mm)	QW	RW	S	T	W	X	Y	Z
32	60	33	140	19	157	33	10	7.5
40	84	35	180	21	187	39.5	12.5	7.5

\* PA dimension is the center sorted factor of the L dimension.

Note) Rc, NPT and G ports can be selected.

**Long Stroke**

(mm)

Bore size (mm)	Stroke range (mm)	X	Y	Z
32	125, 150, 175, 200, 250, 300	45.5	10	10
40	125, 150, 175, 200, 250, 300	55	12.5	12.5

## Minimum Stroke for Mounting of Auto Switch

Application	Auto switch model No. of auto switches mounted	(mm)						
		D-M9□V	D-A9□V	D-A9□	D-M9□WV D-M9□AV	D-M9□	D-M9□W D-M9□A	D-P3DWA
CXT□12 to CXT□25	1	5	5	10	10	15	20	15
CXT□32 to CXT□40	1	5	5	10	10	10	15	15
	2	5	10	10	15	10	15	15

\* D-P3DW is compatible with ø25 to ø40.

Application	Auto switch model No. of auto switches mounted	(mm)						
		D-F7□V D-J79C	D-A7□ D-A8□ D-A73C D-A80C	D-F7□WV D-F7BAV	D-A7□H D-A80H D-F7□ D-J79	D-A79W	D-F7□W D-J79W D-F7BA D-F7NT D-F79F	
CXT□32 to CXT□40	1	5	5	10	15	15	20	
	2	5	10	15	15	20	20	

## Proper Auto Switch Mounting Position (Detection at stroke end) and Its Mounting Height

D-M9□  
D-M9□W  
D-M9□A  
D-M9□V  
D-M9□WV  
D-M9□AV  
D-A9□  
D-A9□V  
D-P3DWA□

ø12

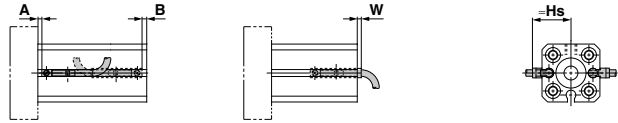

ø16, 20, 25

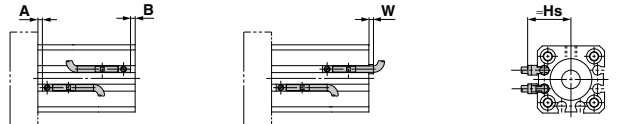

ø32, 40

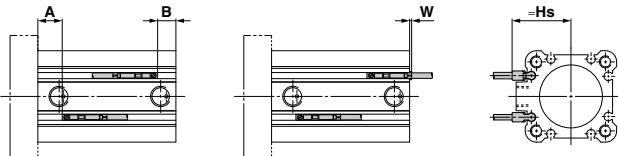

## Proper Auto Switch Mounting Position/Standard Stroke

(mm)

Auto switch model Bore size	D-M9□/M9□V D-M9□W/M9□WV			D-M9□A D-M9□AV			D-A9□ D-A9□V			D-P3DWA	
	A	B	W	A	B	W	A	B	W	A	B
12	5.5	4.5	5.5	5.5	4.5	7.5	1.5	0	1.5(4)	—	—
16	6	4	6	6	4	8	2	0	2(4.5)	—	—
20	10	7.5	2.5	10	7.5	4.5	6	3.5	-1.5(1)	—	—
25	11	9.5	0.5	11	9.5	2.5	7	5.5	-3.5(-1)	6.5	5
32	12	9	1	12	9	3	8	5	-3(-0.5)	7.5	4.5
40	16	11.5	-1.5	16	11.5	0.5	12	7.5	-5.5(-9)	11.5	7

## Auto Switch Mounting Height/Standard Stroke, Long Stroke

(mm)

Auto switch model Bore size	D-M9□V D-M9□WV D-M9□AV	D-A9□V	D-P3DWA
	Hs	Hs	Hs
12	19	17	—
16	21	19	—
20	24	22.5	—
25	26	24.5	33
32	29	27	35.5
40	32.5	30.5	39

## Proper Auto Switch Mounting Position/Long Stroke

(mm)

Auto switch model Bore size	D-M9□/M9□V D-M9□W/M9□WV			D-M9□A D-M9□AV			D-A9□ D-A9□V			D-P3DWA	
	A	B	W	A	B	W	A	B	W	A	B
12	9	11	-1	9	11	1	5	7	-5(-2.5)	—	—
16	9.5	10.5	-0.5	9.5	10.5	1.5	5.5	6	-4.5(-2)	—	—
20	13	16	-6	13	16	-4	9	11.5	-10(-7.5)	—	—
25	14	18	-8	14	18	-6	10	13.5	-12(-9.5)	6.5	5
32	12.5	20.5	-10.5	12.5	20.5	-8.5	8.5	16.5	-14.5(-12)	8	16
40	16	26.5	-16.5	16	26.5	-14.5	12	22.5	-20.5(-18)	11.5	22

Note 1) ( ): Denotes the values of D-A93.

Note 2) W is applicable when mounting D-A9□, D-M9□, D-M9□W and D-M9□A.

Note 3) Adjust the auto switch after confirming the operating conditions in the actual setting.

**Auto Switch Proper Mounting Position (Detection at Stroke End) and Its Mounting Height**

D-A7□ D-F7□ D-F7□V  
 D-A80 D-J79 D-J79C  
 D-A73C D-F7□W D-F7□WV  
 D-A80C D-J79W D-F7BAV  
 D-A79W D-F7BA  
 D-A7□H D-F79F  
 D-A80H D-F7NT

∅32, 40

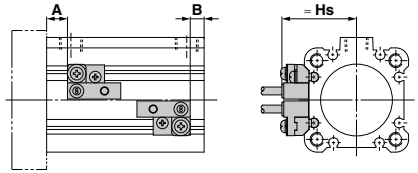

**Auto Switch Proper Mounting Position/Standard Stroke** (mm)

Auto switch model	D-A73 D-A80		D-A72/A7□H D-A80H/A73C D-A80C/F7□/J79 D-F7□W/J79W D-F7□V/F7□WV D-F79F/J79C D-F7BA/F7BAV		D-A79W		D-F7NT	
	A	B	A	B	A	B	A	B
32	9	6	9.5	6.5	6.5	3.5	14.5	10.5
40	13	8.5	13.5	9	10.5	6	18.5	13

**Auto Switch Proper Mounting Position/Long Stroke** (mm)

Auto switch model	D-A73 D-A80		D-A72/A7□H D-A80H/A73C D-A80C/F7□/J79 D-F7□W/J79W D-F7□V/F7□WV D-F79F/J79C D-F7BA/F7BAV		D-A79W		D-F7NT	
	A	B	A	B	A	B	A	B
32	9.5	17.5	10	18	7	15	15	23
40	13	23.5	13.5	24	10.5	21	18.5	29

Note ) Adjust the auto switch after confirming the operating conditions in the actual setting.

**Auto Switch Mounting Height/Standard Stroke, Long Stroke** (mm)

Auto switch model	D-A7□ D-A80		D-A73C D-A80C		D-A79W	D-F7□V D-F7□WV D-F7BV	D-J79C
	Hs	Hs	Hs	Hs	Hs	Hs	Hs
32	31.5	32.5	38.5	34	35	38	
40	35	36	42	37.5	38.5	41.5	

**Operating Range**

Auto switch model	Bore size					
	12	16	20	25	32	40
D-M9□/M9□V D-M9□W/M9□WV D-M9□A/M9□AV	2.5	4	5.5	5.5	6	5.5
D-A9□/A9□V	6	7.5	10	10	9.5	9.5
D-F7□/F7□V D-J79/J79C D-F7□W/F7□WV D-J79W D-F7BA/F7BAV D-F7NT/F79F	—	—	—	—	6	6
D-A7□/A80	—	—	—	—	12	11
D-A79W	—	—	—	—	13	14
D-P3DWA	—	—	—	6	6	6

\* Since this is a guideline including hysteresis, not meant to be guaranteed. (Assuming approximately ±30% dispersion). There may be the case it will vary substantially depending on an ambient environment.  
 \* Auto switch mounting brackets BQ2-012 are not used for sizes over ∅32 of D-A9□(V)/M9□(V)/M9□W(V)/M9□A(V) types. The above values indicate the operating range when mounted with the current auto switch installation groove.

# Auto Switch Mounting 2

## Auto Switch Mounting Bracket: Part No.

Applicable auto switch	D-M9□/M9□V D-M9□W/M9□WV D-M9□A/M9□AV D-A9□/A9□V	D-F7□/F7□V/J79/J79C/F7□W/J79W/F7□WV D-F7BA/F7BAV/F79F/F7NT D-A7□/A80/A7□H/A80H/A73C/A80C/A79W	D-P3DWA											
Bore size (mm)	φ12 to φ40	φ32, φ40	φ25, φ40											
Auto switch mounting bracket part no.	—	BQ5-032	—											
Auto switch mounting bracket fitting parts lineup/Weight	—	<ul style="list-style-type: none"> <li>• Auto switch fixing screw (M2.5 x 10L)</li> <li>• Auto switch mounting screw (M3 x 8L)</li> <li>• Auto switch spacer</li> <li>• Auto switch mounting nut</li> </ul> Weight: 3.5 g	—											
Auto switch mounting surface	Surfaces with auto switch mounting slot	A/B/C side except port side	Surfaces with auto switch mounting slot											
Mounting of auto switch	<p>• When tightening the auto switch mounting screw, use a watchmakers' screwdriver with a handle 5 to 6 mm in diameter.</p> <p><b>Tightening torque for auto switch mounting screw (N·m)</b></p> <table border="1"> <thead> <tr> <th>Auto switch model</th> <th>Tightening torque</th> </tr> </thead> <tbody> <tr> <td>D-M9□(V)</td> <td rowspan="3">0.05 to 0.15</td> </tr> <tr> <td>D-M9□W(V)</td> </tr> <tr> <td>D-A93</td> </tr> <tr> <td>D-M9□A(V)</td> <td>0.05 to 0.10</td> </tr> <tr> <td>D-A9□(V)</td> <td rowspan="2">0.10 to 0.20</td> </tr> <tr> <td>(Excludes the D-A93)</td> </tr> </tbody> </table>	Auto switch model	Tightening torque	D-M9□(V)	0.05 to 0.15	D-M9□W(V)	D-A93	D-M9□A(V)	0.05 to 0.10	D-A9□(V)	0.10 to 0.20	(Excludes the D-A93)	<ol style="list-style-type: none"> <li>Insert the nut into the auto switch mounting slot on the cylinder tube, and place it in the roughly estimated setting position.</li> <li>With the lower tapered part of the auto switch spacer facing the outside of the cylinder tube, line up the M2.5 through hole with the M2.5 female thread of the auto switch mounting nut.</li> <li>Gently screw the auto switch mounting nut fixing screw (M2.5) into the thread of the auto switch mounting nut through the mounting hole.</li> <li>Engage the ridge on the auto switch mounting arm with the recess in the auto switch spacer.</li> <li>Tighten the auto switch mounting screw (M3) to fix the auto switch. The tightening torque of the M3 screw must be 0.35 to 0.45 N·m.</li> <li>Confirm where the mounting position is, and tighten the auto switch fixing screw (M2.5) to fix the auto switch mounting nut. The tightening torque of the M2.5 screw must be 0.25 to 0.35 N·m.</li> <li>The detection position can be changed under the conditions in step ⑤.</li> </ol>	<ol style="list-style-type: none"> <li>Insert the mounting bracket into the mating groove of the cylinder tube.</li> <li>Check the detecting position of the auto switch and fix the auto switch firmly with the hexagon socket head cap screw (M2.5 x 12L).*</li> <li>If the detecting position is changed, go back to step ①.</li> </ol> <p>Note 1) Ensure that the auto switch is covered with the mating groove to protect the auto switch.</p> <p>Note 2) The tightening torque for the hexagon socket head cap screw (M2.5 x 12L) is 0.2 to 0.3 N·m.</p> <p>Hexagon socket head cap screw (M2.5 x 12L) (Included with auto switch)</p>
Auto switch model	Tightening torque													
D-M9□(V)	0.05 to 0.15													
D-M9□W(V)														
D-A93														
D-M9□A(V)	0.05 to 0.10													
D-A9□(V)	0.10 to 0.20													
(Excludes the D-A93)														

Note ) When shipping cylinders, auto switch mounting brackets and auto switches are shipped together.

### Other Applicable Auto Switches refer to pages 1289 to 1383 for the detailed specifications of auto switches.

Auto switch type	Model	Electrical entry (Fitching direction)	Features
Reed	D-A73	Grommet (Perpendicular)	—
	D-A80		Without indicator light
	D-A73H, A76H	Grommet (In-line)	—
	D-A80H		Without indicator light
Solid state	D-F7NV, F7PV, F7BV	Grommet (Perpendicular)	Diagnostic indicator (2-color indicator)
	D-F7NWW, F7BWW		Water resistant (2-color indicator)
	D-F7BAV		Water resistant (2-color indicator)
	D-F79, F7P, J79	Grommet (In-line)	Diagnostic indicator (2-color indicator)
	D-F79W, F7PW, J79W		Water resistant (2-color indicator)
	D-F7BA		Water resistant (2-color indicator)
	D-F7NT		With timer

\* For solid state auto switches, auto switches with a pre-wired connector are also available. Refer to pages 1358 and 1359 for details.

\* Normally closed (NC = b contact) solid state auto switches (D-M9□E(V)) are also available. For details, refer to page 1308.

\* D-A7/A8/F7/J7 types cannot be mounted on φ12 to φ25.

• If the cylinder is used in an application in which a magnetic material is placed in close contact around the cylinder as shown in the graph on the below (including cases in which even one of the sides is in close contact) the operation of auto switches could become unstable. Therefore, please check with SMC for this type of application.

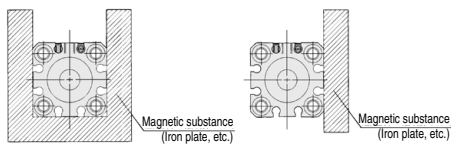

## 1 Adjustable Stroke

Symbol

**-X138**

The stroke adjustment range may be expanded with a long adjustment bolt.

### How to Order

CXT Standard model no. — X138

• Adjustable stroke

### Specifications

Model	CXT□12, 16	CXT□20, 25	CXT□32	CXT□40
Stroke adjustment range	-26 mm (Single side -13 mm)	-28 mm (Single side -14 mm)	-44 mm (Single side -22 mm)	-40 mm (Single side -20 mm)

\* Specifications other than the above are the same as the standard type.

### Dimensions (Dimensions other than those below are the same as the standard type.)

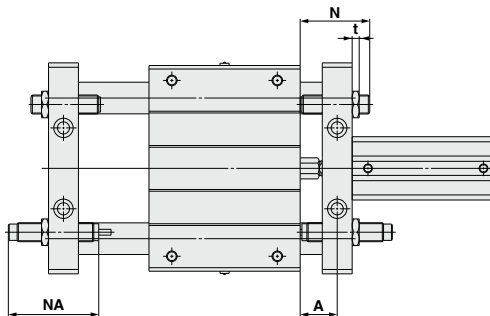

Cylinder bore (mm)	(mm)			
	A	N	NA	t
12	8.5 to 21.5	32	40.8	4
16	7.5 to 20.5	32	40.8	4
20	9.5 to 23.5	37	46.7	4
25	9.5 to 23.5	39	67.3	6
32	10.5 to 32.5	49	73.2	6
40	11.5 to 31.5	49	73.2	6

## 2 Fluororubber Seal (Cylinder unit only)

Symbol

**-X777**

Fluororubber is used only for the cylinder unit seal.

### How to Order

CXT Standard model no. — X777

• Fluororubber seal (Cylinder unit only)

### Specifications

Seal material	Fluororubber (Cylinder unit only)
---------------	-----------------------------------

\* Specifications other than the above are the same as the standard type.



## CXT Series

# Specific Product Precautions

Be sure to read this before handling the products.

Refer to page 8 for safety instructions and pages 9 to 18 for actuator and auto switch precautions.

### Operating Precautions

#### Caution

1. Make sure not to apply to the slide block a load that exceeds the value that has been calculated in the selection procedures.
2. Operate the cylinder securing it by its plates, not by securing it by its slide block.
3. The clearance between the slide block and the plate at the stroke end is approximately 1 mm to 6 mm. It could be extremely dangerous, as there is the risk of getting your fingers caught.  
Install a cover as necessary.
4. At both stroke ends, adjust the damper portion at the end of the adjusting bolt so that it comes in contact with the slide block. (The clearance between the slide block and the plate must be 1 mm or more.)  
If it is operated without making any contact, the piston rod of the actuating cylinder or the connecting hardware (adapter) could become damaged by an excessive impact, or the slide block could collide with the plate and create an abnormal noise.
5. The load weight or operating speed will be limited if only the adjusting bolt is used.  
Refer to the section on "Allowable load when only the adjustment bolt is used" on page 711
6. Please contact SMC if this product will be used in an environment in which the piston rod and the guide shaft surfaces will be exposed to water (hot water), coolant, cutting chips, or dust.
7. The slide block bearings must be greased periodically. Inject grease (Class 1 or 2 lithium soap grease consistency) through the grease inlet.  
Note) On those with a cylinder bore of  $\phi 12$ , apply grease to the guide shaft.
8. To operate the cylinder, use a non-lubricating air supply. Use turbine oil Class 1 (ISO VG32), if lubricated. (Using machine oil or spindle oil are not allowed.)

### Mounting

#### Caution

1. While a high level of flatness is desired for the surface on which the cylinder is to be mounted, if sufficient flatness cannot be attained, use shims to adjust the installation of the cylinder so that the slide block can operate throughout its stroke under the minimum operating pressure.
2. Do not scratch or gouge the piston rod of the actuating cylinder, as this could damage the rod seal and lead to air leaks.  
The same applies to the guide shaft.
3. Make sure not to apply shocks or excessive moment to the slide block of the ball bushing type.
4. The port direction of the actuating cylinder can be changed in 90° increments by removing the four bolts that secure the cylinder in place.  
After changing the direction, verify the operation at the minimum operating pressure.
5. Before the installation, thoroughly flush out the piping to prevent dust or cutting chips from entering the cylinder.
6. The mounting position of the adjusting bolt and the shock absorber cannot be inverted due to the constraints imposed by the locating pin for the shock absorber that is provided on the slide block.  
To invert the position, please contact SMC.

### Handling on Shock Absorber

#### Caution

1. The RB series (SMC made) shock absorbers can absorb a wide range of energy without requiring adjustment. (No adjustment screw is provided.)
2. The screw at the bottom is not for adjustment.  
Never turn this screw as it could cause an oil leak (lowered performance).
3. Do not scratch the surface of the shock absorber rod because doing so could affect the shock absorber's durability or lead to poor retraction.  
  
\* For detailed specifications about the shock absorber, refer to the Web Catalog.

### Service Life and Replacement Period of Shock Absorber

#### Caution

1. Allowable operating cycle under the specifications set in this catalog is shown below.  
1.2 million cycles RB08□□  
2 million cycles RB10□□ to RB2725  
  
Note) Specified service life (suitable replacement period) is the value at room temperature (20 to 25°C). The period may vary depending on the temperature and other conditions. In some cases the absorber may need to be replaced before the allowable operating cycle above.