

# Dual Rod Cylinder

RoHS

ø12, ø16, ø20, ø25, ø32, ø40, ø50, ø63, ø80, ø100

Cylinder suitable for **pushing**, **lifting**, or **clamping**

**Overall length**

Reduced by up to **48%**

**114 mm** → **59.5 mm**

CXSM20  
20 mm stroke  
(ø20 x 2)\*1

JMGPM25  
20 mm stroke  
(ø20 x 2)\*1



**CXSM20**

**JMGP25**

**59.5 mm**

**54.5 mm shorter**  
(Compared at a 20 mm stroke)

**Weight**

Reduced by up to **38%**

**1.28 kg** → **0.8 kg**

CXSM32  
25 mm stroke  
(ø32 x 2)\*1

JMGPM40  
25 mm stroke  
(ø32 x 2)\*1

**Allowable lateral load**

Increased by **6.6 times**

**0.06 kg** → **0.4 kg**

CXSM10  
50 mm stroke  
(ø10 x 2)\*1

JMGPM12  
50 mm stroke  
(ø10 x 2)\*1

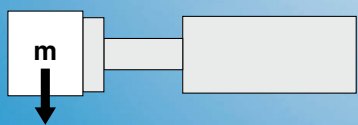

**Non-rotating accuracy**

Improved by up to **40%**

**±0.1°** → **±0.06°**

CXSM32  
25 mm stroke  
(ø32 x 2)\*1

JMGPM40  
25 mm stroke  
(ø32 x 2)\*1

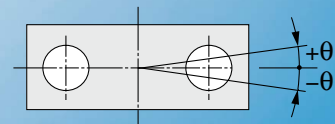

\*1 Both cylinders used in the comparison have almost the same piston area.

**JMGP Series**

**SMC**  
CAT.ES20-238D

# Allowable lateral load increased by 6.6 times

\* Compared with the CXSM series, 50 mm stroke

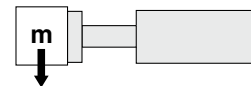
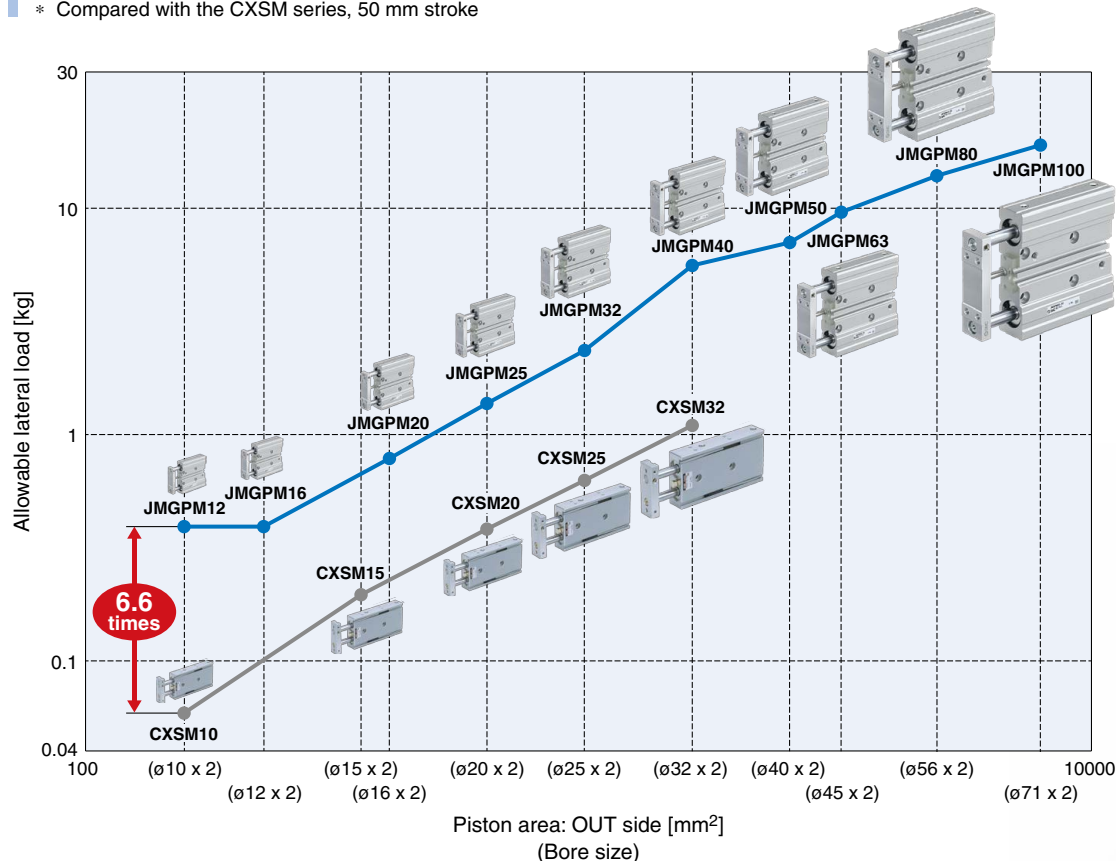

## Short pitch mounting is possible.

Cylinders can be installed adjacent to each other.

Mounting interval: 0 to 15 mm\*1

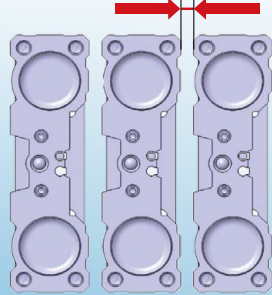
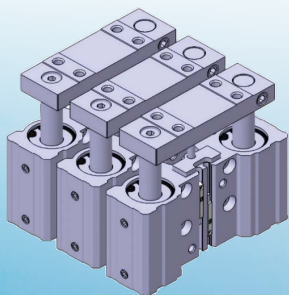

\*1 Differs depending on the bore size  
For details, refer to [p. 11](#)

### Internal structure

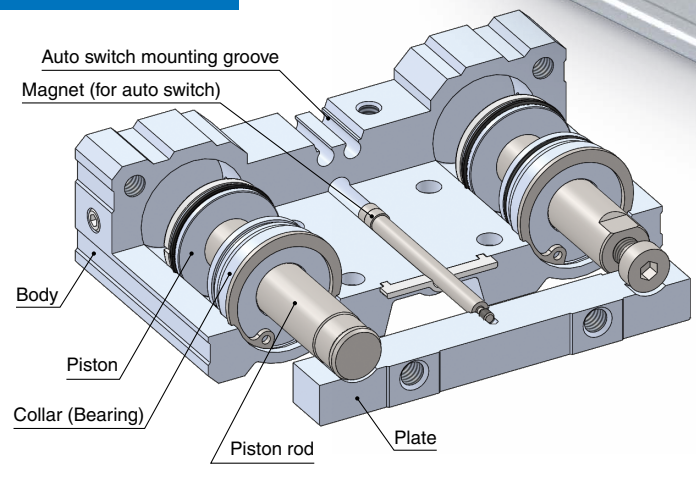

## Series Variations

Model	Bearing	Bore size	Stroke [mm]	Cushion	Piston speed	Port size	Mounting direction
<b>JMGP</b>	Slide bearing	ø12 (ø10 x 2)	10, 20, 30, 50, 100	Rubber bumper on both ends	50 to 300 mm/s	M3 x 0.5	Top Bottom Rear
		ø16 (ø12 x 2)					
		ø20 (ø16 x 2)					
		ø25 (ø20 x 2)	20, 30, 50, 100, 150			M5 x 0.8	
		ø32 (ø25 x 2)					
		ø40 (ø32 x 2)					
		ø50 (ø40 x 2)	25, 50, 100, 150, 200		1/8 (Rc, NPT, G)		
		ø63 (ø45 x 2)					
		ø80 (ø56 x 2)					
ø100 (ø71 x 2)	50 to 250 mm/s	1/4 (Rc, NPT, G)					

D-M9□ solid state auto switches are mountable.



### 3 mounting options

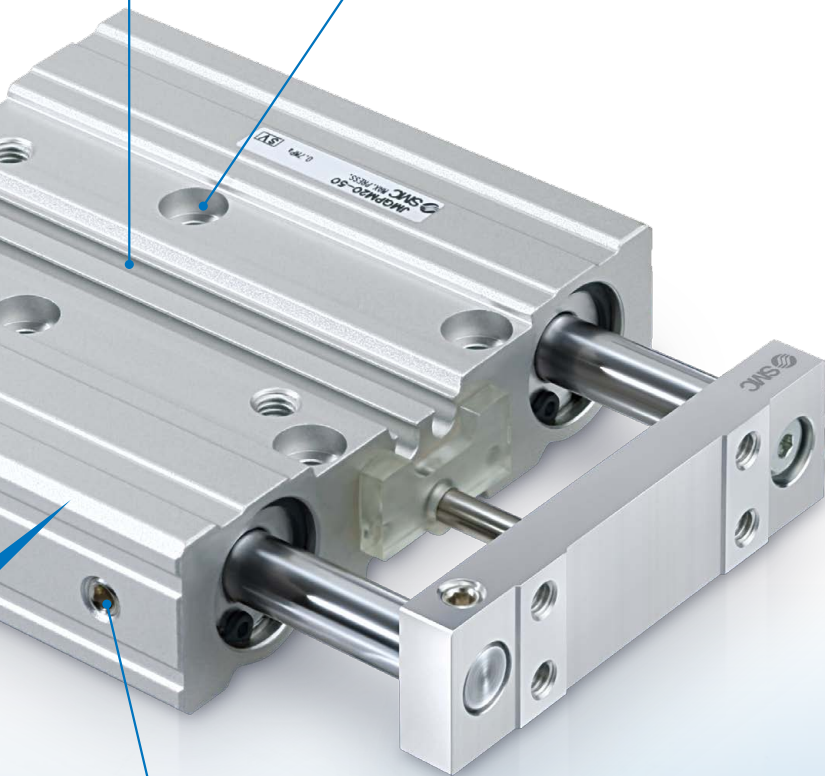
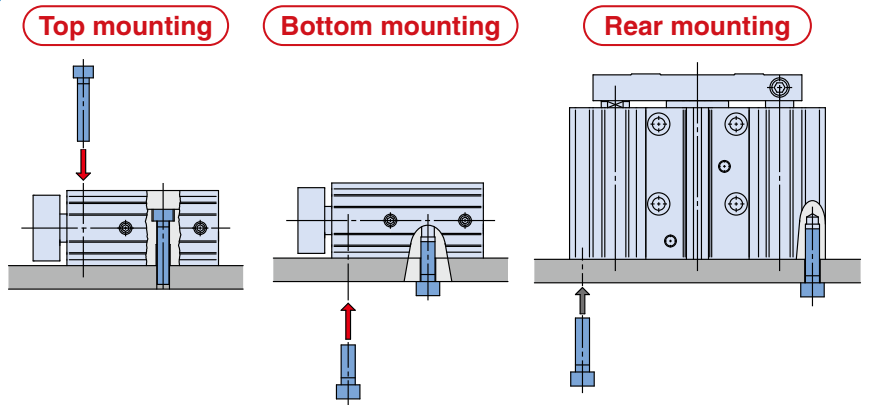

### Application Examples

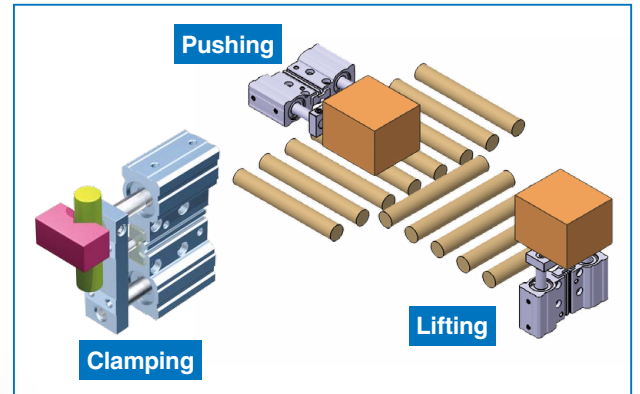

Piping is possible in 4 directions.

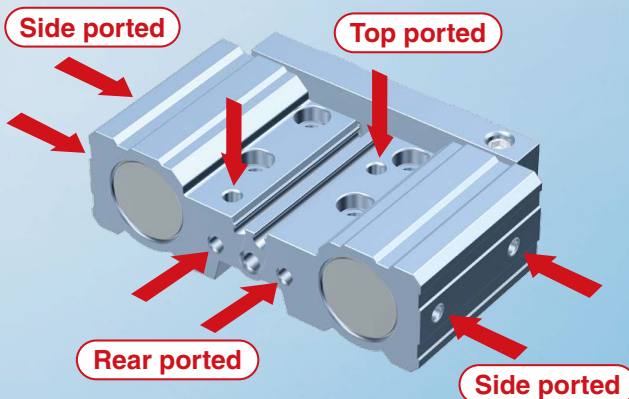

### Related Product

For the  $\phi 12$  and  $\phi 16$  JMGP Speed Controller with One-touch Fitting Elbow Type for M3

p. 13



### CONTENTS

How to Order	p. 3
Specifications	p. 4
Dimensions	p. 6
Auto Switch Mounting	p. 10
Prior to Use	
Auto Switch Connections and Examples	p. 12
Related Product	p. 13
Specific Product Precautions	p. 14
Safety Instructions	Back cover

# Dual Rod Cylinder

## JMGP Series

ø12, ø16, ø20, ø25, ø32, ø40, ø50, ø63, ø80, ø100

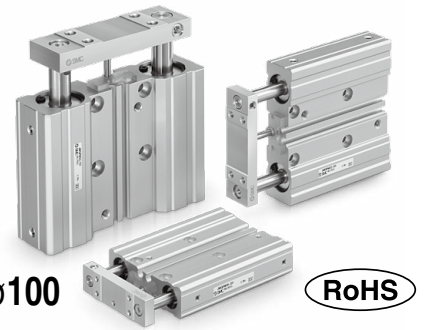

### How to Order

**JMGPM 25** - **30** - **M9BW**

**Bearing type**  
**M** Slide bearing

**Bore size**

12	10 mm x 2
16	12 mm x 2
20	16 mm x 2
25	20 mm x 2
32	25 mm x 2
40	32 mm x 2
50	40 mm x 2
63	45 mm x 2
80	56 mm x 2
100	71 mm x 2

**Port thread type**

Nil	M thread	ø12 to ø32
	Rc	
TN	NPT	ø40 to ø100
TF	G	

**Number of auto switches**

Nil	2
S	1
n	n

**Auto switch**

Nil	Without auto switch (Built-in magnet)
-----	---------------------------------------

\* For applicable auto switches, refer to the table below.

**Cylinder stroke [mm]**

Bore size	Standard stroke [mm]
ø12 (ø10 x 2) ø16 (ø12 x 2)	10, 20, 30, 50, 100
ø20 (ø16 x 2) ø25 (ø20 x 2)	20, 30, 50, 100, 150
ø32 (ø25 x 2) ø40 (ø32 x 2) ø50 (ø40 x 2) ø63 (ø45 x 2) ø80 (ø56 x 2) ø100 (ø71 x 2)	25, 50, 100, 150, 200

\* Refer to page 4 for intermediate strokes.

### Applicable Auto Switches/Refer to the Web Catalog for further information on auto switches.

Type	Special function	Electrical entry	Indicator/light	Wiring (Output)	Load voltage		Auto switch model		Lead wire length [m]				Pre-wired connector	Applicable load		
					DC	AC	Perpendicular	In-line	0.5 (Nil)	1 (M)	3 (L)	5 (Z)				
Solid state auto switch	—	Grommet	Yes	3-wire (NPN)	24 V	5 V, 12 V	—	M9NV	M9N	●	●	●	○	○	IC circuit	Relay, PLC
				3-wire (PNP)				M9PV	M9P	●	●	●	○	○		
				2-wire				M9BV	M9B	●	●	●	○	○		
	3-wire (NPN)			M9NWV				M9NW	●	●	●	○	○	IC circuit		
	3-wire (PNP)			M9PWV				M9PW	●	●	●	○	○			
	2-wire			M9BWV				M9BW	●	●	●	○	○	—		
	Diagnostic indication (2-color indicator)			M9NAV*1	M9NA*1	○	○	●	○	○	IC circuit					
				M9PAV*1	M9PA*1	○	○	●	○	○						
				Water resistant (2-color indicator)	M9BAV*1	M9BA*1	○	○	●	○		○	—			

\*1 Water-resistant type auto switches can be mounted on the above models, but SMC cannot guarantee water resistance. Please contact SMC regarding water-resistant types with the above model numbers.

\* Lead wire length symbols: 0.5 m.....Nil (Example) M9NW  
 1 m.....M (Example) M9NWM  
 3 m.....L (Example) M9NWL  
 5 m.....Z (Example) M9NWZ

\* Solid state auto switches marked with a "○" are produced upon receipt of order.

\* For details on auto switches with pre-wired connectors, refer to the Web Catalog.

\* Auto switches are shipped together with the product but do not come assembled.





**Symbol**  
Rubber bumper

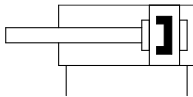

Refer to pages 10 and 11 for cylinders with auto switches.

- Auto Switch Proper Mounting Position (Detection at stroke end) and Mounting Height
- Minimum Stroke for Auto Switch Mounting
- Operating Range
- Auto Switch Mounting

## Specifications

Bore size	ø12 (ø10 x 2)	ø16 (ø12 x 2)	ø20 (ø16 x 2)	ø25 (ø20 x 2)	ø32 (ø25 x 2)	ø40 (ø32 x 2)	ø50 (ø40 x 2)	ø63 (ø45 x 2)	ø80 (ø56 x 2)	ø100 (ø71 x 2)
<b>Action</b>	Double acting									
<b>Fluid</b>	Air									
<b>Proof pressure</b>	1.05 MPa									
<b>Max. operating pressure</b>	0.7 MPa									
<b>Min. operating pressure</b>	0.15 MPa									
<b>Ambient and fluid temperatures</b>	5 to 60°C									
<b>Piston speed</b> *1, *2	50 to 300 mm/s								50 to 250 mm/s	
<b>Cushion</b>	Rubber bumper on both ends									
<b>Lubrication</b>	Not required (Non-lube)									
<b>Stroke length tolerance</b>	$\begin{matrix} +1.5 \\ 0 \end{matrix}$ mm									

\*1 Max. speed with no load

\*2 Depending on the system configuration selected, the specified speed may not be satisfied.

## Manufacturing of Intermediate Strokes

<b>Description</b>	Spacer installation type Spacers are installed in the standard stroke cylinder. · Stroke can be modified in 5 mm increments.	
<b>Part no.</b>	Refer to the standard model numbers.	
<b>Applicable stroke [mm]</b>	ø12 (ø10 x 2)	5 to 95
	ø16 (ø12 x 2)	
	ø20 (ø16 x 2)	5 to 145
	ø25 (ø20 x 2)	
	ø32 (ø25 x 2)	5 to 195
	ø40 (ø32 x 2)	
	ø50 (ø40 x 2)	
	ø63 (ø45 x 2)	
ø80 (ø56 x 2)		
ø100 (ø71 x 2)		
<b>Example</b>	Part no.: JMGP20-45 A 5 mm width spacer is installed in the JMGP20-50. The C dimension is 77.5 mm.	

## Theoretical Output

Bore size	Rod size [mm]	Operating direction	Piston area [mm <sup>2</sup> ]	Operating pressure [MPa]					
				0.2	0.3	0.4	0.5	0.6	0.7
ø12 (ø10 x 2)	6	OUT	157	31	47	63	79	94	110
		IN	101	20	30	40	50	60	70
ø16 (ø12 x 2)	6	OUT	226	45	68	90	113	136	158
		IN	170	34	51	68	85	102	119
ø20 (ø16 x 2)	8	OUT	402	80	121	161	201	241	281
		IN	302	60	90	121	151	181	211
ø25 (ø20 x 2)	10	OUT	628	126	188	251	314	377	440
		IN	471	94	141	188	236	283	330
ø32 (ø25 x 2)	12	OUT	982	196	295	393	491	589	687
		IN	756	151	227	302	378	453	529
ø40 (ø32 x 2)	16	OUT	1608	322	483	643	804	965	1126
		IN	1206	241	362	483	603	724	844
ø50 (ø40 x 2)	18	OUT	2513	503	754	1005	1257	1508	1759
		IN	2004	401	601	802	1002	1203	1403
ø63 (ø45 x 2)	20	OUT	3181	636	954	1272	1590	1909	2227
		IN	2553	511	766	1021	1276	1532	1787
ø80 (ø56 x 2)	25	OUT	4926	985	1478	1970	2463	2956	3448
		IN	3944	789	1183	1578	1972	2367	2761
ø100 (ø71 x 2)	30	OUT	7918	1584	2376	3167	3959	4751	5543
		IN	6505	1301	1951	2602	3252	3903	4553

\* Theoretical output [N] = Pressure [MPa] x Piston area [mm<sup>2</sup>]

## Weight

Bore size [mm]	Stroke [mm]							
	10	20	25	30	50	100	150	200
ø12 (ø10 x 2)	0.09	0.12	—	0.14	0.19	0.30	—	—
ø16 (ø12 x 2)	0.10	0.13	—	0.15	0.20	0.32	—	—
ø20 (ø16 x 2)	—	0.21	—	0.25	0.33	0.53	0.72	—
ø25 (ø20 x 2)	—	0.28	—	0.33	0.43	0.68	0.92	—
ø32 (ø25 x 2)	—	—	0.60	—	0.77	1.11	1.44	1.78
ø40 (ø32 x 2)	—	—	0.80	—	1.07	1.62	2.16	2.70
ø50 (ø40 x 2)	—	—	1.27	—	1.63	2.36	3.09	3.82
ø63 (ø45 x 2)	—	—	1.60	—	2.03	2.89	3.74	4.60
ø80 (ø56 x 2)	—	—	2.81	—	3.47	4.79	6.12	7.44
ø100 (ø71 x 2)	—	—	4.48	—	5.40	7.22	9.05	10.87

# JMGP Series

## Allowable Rotational Torque of Plate

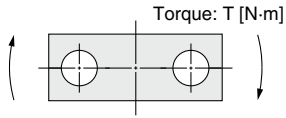

Bore size	Stroke [mm]							
	10	20	25	30	50	100	150	200
ø12 (ø10 x 2)	0.13	0.10	—	0.08	0.06	0.04	—	—
ø16 (ø12 x 2)	0.14	0.11	—	0.09	0.07	0.04	—	—
ø20 (ø16 x 2)	—	0.27	—	0.22	0.16	0.10	0.07	—
ø25 (ø20 x 2)	—	0.54	—	0.45	0.34	0.21	0.15	—
ø32 (ø25 x 2)	—	—	0.93	—	0.66	0.42	0.31	0.24
ø40 (ø32 x 2)	—	—	2.18	—	1.59	1.03	0.77	0.61
ø50 (ø40 x 2)	—	—	3.41	—	2.56	1.70	1.27	1.02
ø63 (ø45 x 2)	—	—	5.09	—	3.86	2.60	1.96	1.57
ø80 (ø56 x 2)	—	—	8.48	—	6.56	4.52	3.45	2.79
ø100 (ø71 x 2)	—	—	13.54	—	10.72	7.56	5.84	4.76

## Non-rotating Accuracy of Plate

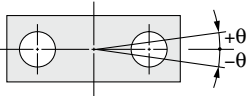

Non-rotating accuracy  $\theta$  when retracted and when no load is applied should be not more than the values shown in the table.

Bore size	Non-rotating accuracy $\theta$
ø12 (ø10 x 2)	±0.07°
ø16 (ø12 x 2)	
ø20 (ø16 x 2)	
ø25 (ø20 x 2)	±0.06°
ø32 (ø25 x 2)	
ø40 (ø32 x 2)	
ø50 (ø40 x 2)	±0.05°
ø63 (ø45 x 2)	
ø80 (ø56 x 2)	
ø100 (ø71 x 2)	±0.04°

## Plate End Deflection

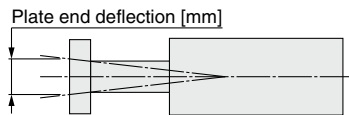

An approximate plate-end deflection without a load is shown in the graph below.

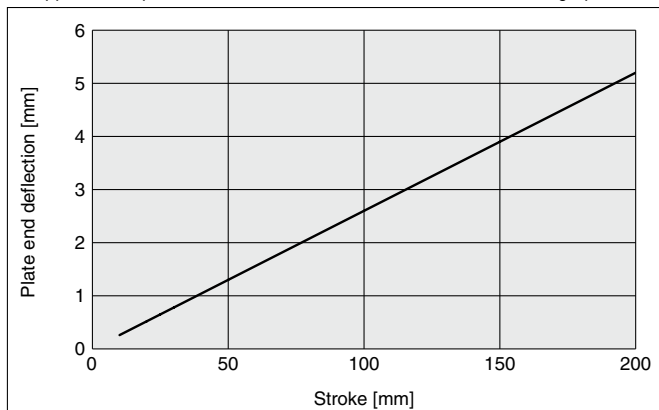

## Allowable Lateral Load

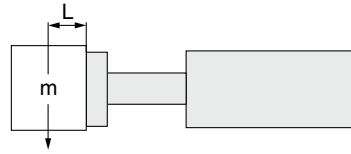

Bore size	Stroke [mm]							
	10	20	25	30	50	100	150	200
ø12 (ø10 x 2)	0.9	0.7	—	0.5	0.4	0.2	—	—
ø16 (ø12 x 2)	0.9	0.7	—	0.6	0.4	0.2	—	—
ø20 (ø16 x 2)	—	1.3	—	1.0	0.8	0.5	0.3	—
ø25 (ø20 x 2)	—	2.3	—	1.9	1.4	0.9	0.6	—
ø32 (ø25 x 2)	—	—	3.4	—	2.4	1.5	1.1	0.9
ø40 (ø32 x 2)	—	—	7.8	—	5.7	3.7	2.7	2.2
ø50 (ø40 x 2)	—	—	9.6	—	7.2	4.8	3.6	2.9
ø63 (ø45 x 2)	—	—	13.0	—	9.8	6.6	5.0	4.0
ø80 (ø56 x 2)	—	—	18.3	—	14.2	9.8	7.5	6.0
ø100 (ø71 x 2)	—	—	24.5	—	19.4	13.7	10.6	8.6

\* Lateral load above is the value when eccentric distance  $L = 0$  mm.

## Allowable Kinetic Energy

### With Rubber Bumper

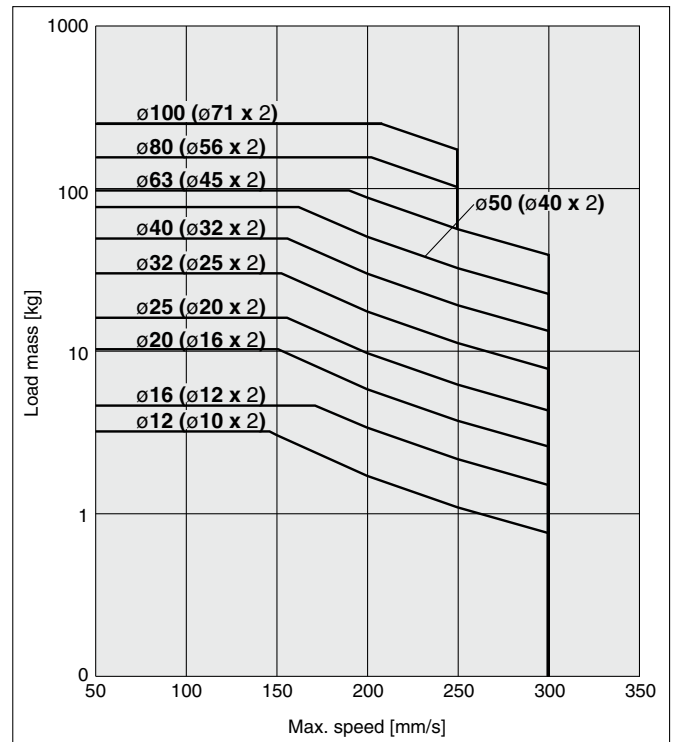

**Bore Size  $\varnothing 12$  ( $\varnothing 10 \times 2$ ),  $\varnothing 16$  ( $\varnothing 12 \times 2$ )**

Standard: JMGP

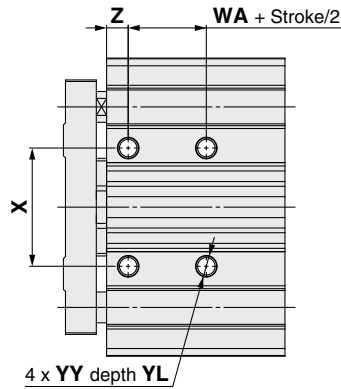

Bottom view

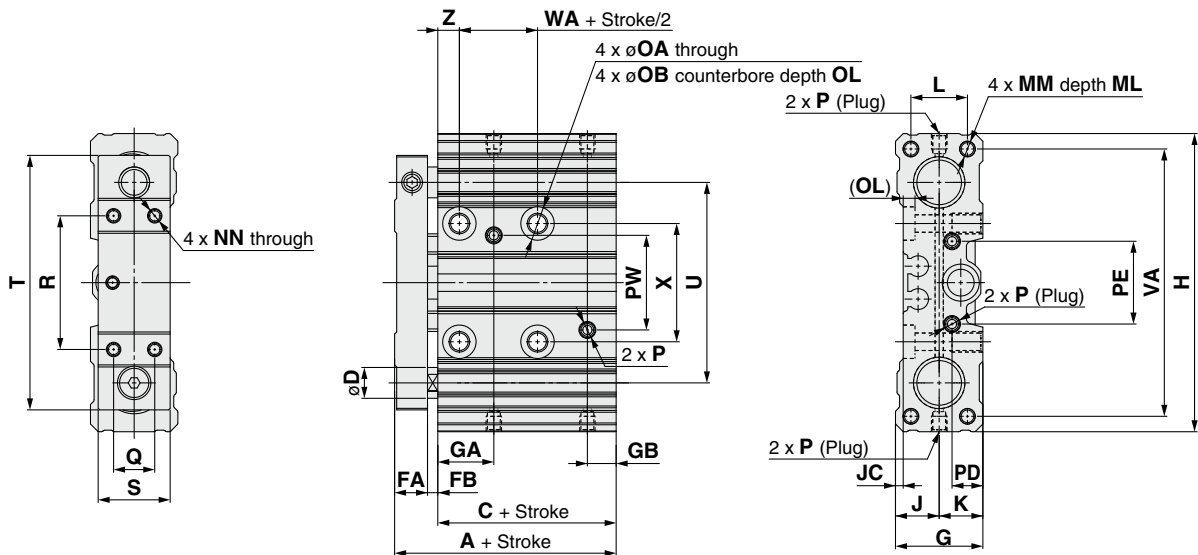

[mm]

Bore size	Standard stroke	A	C	D	FA	FB	G	GA	GB	H	J	JC	K	L	MM	ML	NN
$\varnothing 12$ ( $\varnothing 10 \times 2$ )	10, 20, 30, 50, 100	33	24.5	6	6.5	2	17	11	5.5	58	8.5	1.5	8.5	11	M3 x 0.5	7.5	M2.5 x 0.45
$\varnothing 16$ ( $\varnothing 12 \times 2$ )		33	24.5	6	6.5	2	18	11	5.5	64	9	3	9	11	M4 x 0.7	10	M3 x 0.5

Bore size	OA	OB	OL	P	PD	PE	PW	Q	R	S	T	U	VA	WA	X	YY	YL	Z
$\varnothing 12$ ( $\varnothing 10 \times 2$ )	3.4	6.5	2.5	M3 x 0.5	6	16	18.5	8	26	14	49.5	39	52	10.2	23	M4 x 0.7	6	4.2
$\varnothing 16$ ( $\varnothing 12 \times 2$ )	3.4	6.5	2	M3 x 0.5	6.5	16	18.5	8	28	14	53	42	57	10.2	24	M4 x 0.7	6	4.3

# JMGP Series

Bore Size  $\varnothing 20$  ( $\varnothing 16 \times 2$ ) to  $\varnothing 40$  ( $\varnothing 32 \times 2$ )

Standard: JMGP

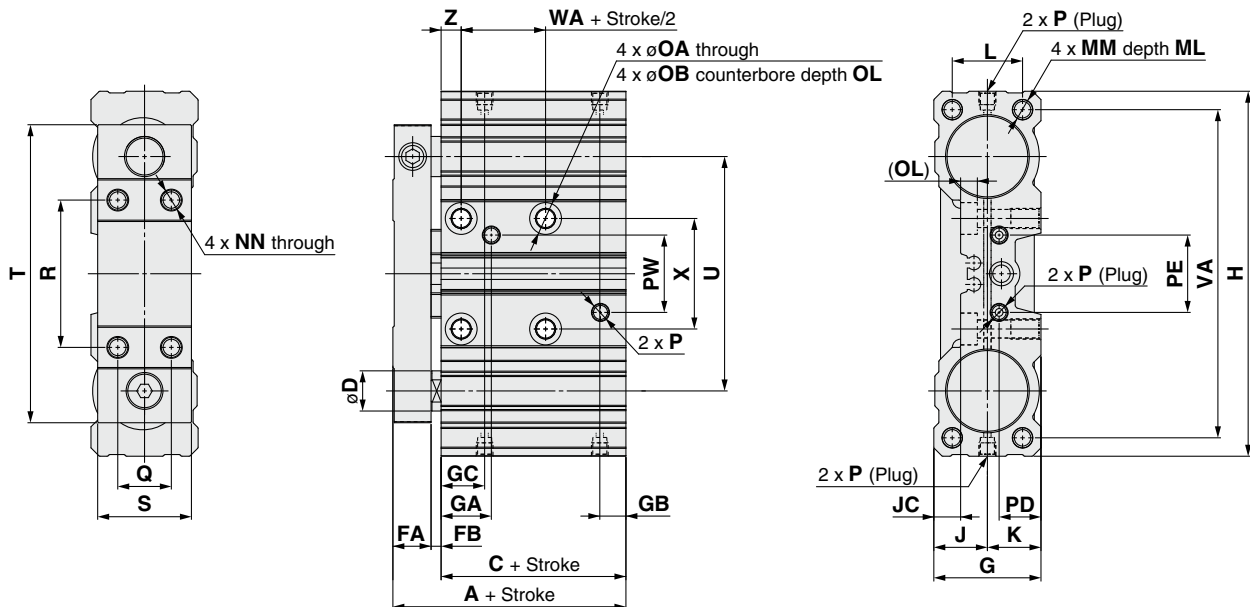
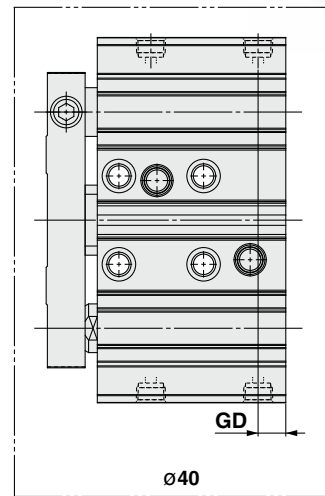
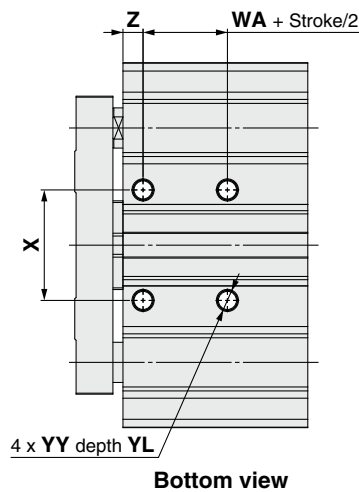

[mm]

Bore size	Standard stroke	A	C	D	FA	FB	G	GA			GB	GC	GD	H	J	JC	K	L	MM	ML	NN
								Nil	TN	TF											
$\varnothing 20$ ( $\varnothing 16 \times 2$ )	20, 30, 50 100, 150	38	27.5	8	7.5	3	22	12.5	—	—	7.5	11	—	83	11	3	11	14	M4 x 0.7	10	M4 x 0.7
$\varnothing 25$ ( $\varnothing 20 \times 2$ )		39.5	28	10	8.5	3	26	12	—	—	7.5	11	—	93	13	4.5	13	17	M5 x 0.8	12.5	M5 x 0.8
$\varnothing 32$ ( $\varnothing 25 \times 2$ )	25, 50, 100 150, 200	44.5	30	12	11.5	3	32	15	—	—	7.5	13	—	109	16	8	16	21	M6 x 1	15	M6 x 1
$\varnothing 40$ ( $\varnothing 32 \times 2$ )		54	37	16	13	4	41	19.5	21	12	17.5	9	120	20.5	4	20.5	27	M8 x 1.25	20	M6 x 1	

Bore size	OA	OB	OL	P			PD	PE	PW			Q	R	S	T	U	VA	WA	X	YY	YL	Z
				Nil	TN	TF			Nil	TN	TF											
$\varnothing 20$ ( $\varnothing 16 \times 2$ )	4.3	8	3.5	M5 x 0.8	—	—	7.5	19	21	—	—	10	36	18	66	54	75	15.9	29	M5 x 0.8	7.5	4.5
$\varnothing 25$ ( $\varnothing 20 \times 2$ )	4.3	8	4	M5 x 0.8	—	—	9.5	22	22	—	—	12	38	22	75	60	84	12.7	31	M5 x 0.8	7.5	4.5
$\varnothing 32$ ( $\varnothing 25 \times 2$ )	5.4	9.5	5	M5 x 0.8	—	—	12.5	23	23	—	—	16	44	28	89	70	98	12.7	33	M6 x 1	9	6
$\varnothing 40$ ( $\varnothing 32 \times 2$ )	6.7	11	6	Rc1/8	NPT1/8	G1/8	13	16.5	26	27.5	20	43	33	97	71	107	15.3	29	M8 x 1.25	10	7.1	



## Bore Size $\varnothing 50$ ( $\varnothing 40 \times 2$ ), $\varnothing 63$ ( $\varnothing 45 \times 2$ )

Standard: JMGP

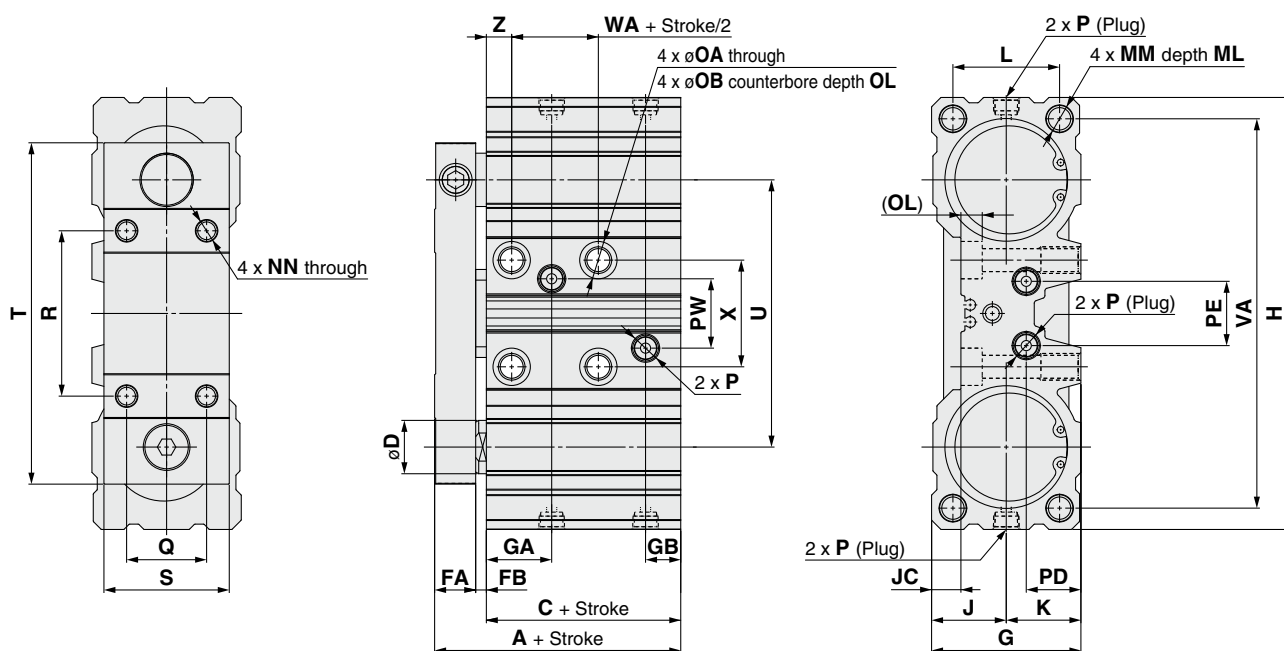
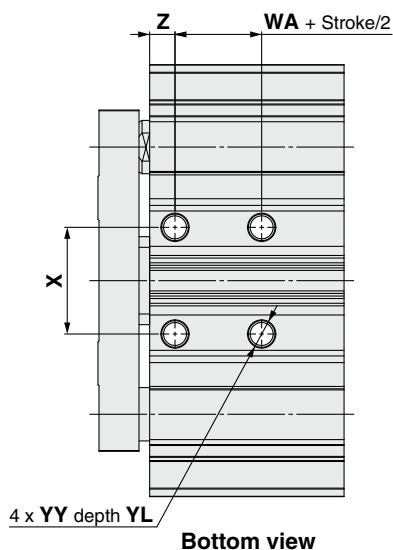

		[mm]															
Bore size	Standard stroke	A	C	D	FA	FB	G	GA	GB	H	J	JC	K	L	MM	ML	NN
$\varnothing 50$ ( $\varnothing 40 \times 2$ )	25, 50, 100, 150, 200	63	43.5	18	15.5	4	51	20.5	12.5	148	25.5	9	25.5	37	M8 x 1.25	20	M8 x 1.25
$\varnothing 63$ ( $\varnothing 45 \times 2$ )		67.5	48	20	15.5	4	56	24.5	13.5	162	28	11	28	40	M10 x 1.5	25	M8 x 1.25

Bore size	OA	OB	OL	P			PD	PE	PW			Q	R	S	T	U	VA	WA	X	YY	YL	Z
				Nil	TN	TF			Nil	TF	TN											
$\varnothing 50$ ( $\varnothing 40 \times 2$ )	6.7	11	6	Rc1/8	NPT1/8	G1/8	18	27	27	30	24	54	39	119	91	135	18.1	40	M8 x 1.25	12	7.6	
$\varnothing 63$ ( $\varnothing 45 \times 2$ )	8.6	14	8	Rc1/8	NPT1/8	G1/8	20.5	24	26	30	30	62	47	128	100	146	20	40	M10 x 1.5	15	9.5	

# JMGP Series

Bore Size  $\varnothing 80$  ( $\varnothing 56 \times 2$ ),  $\varnothing 100$  ( $\varnothing 71 \times 2$ )

Standard: JMGP

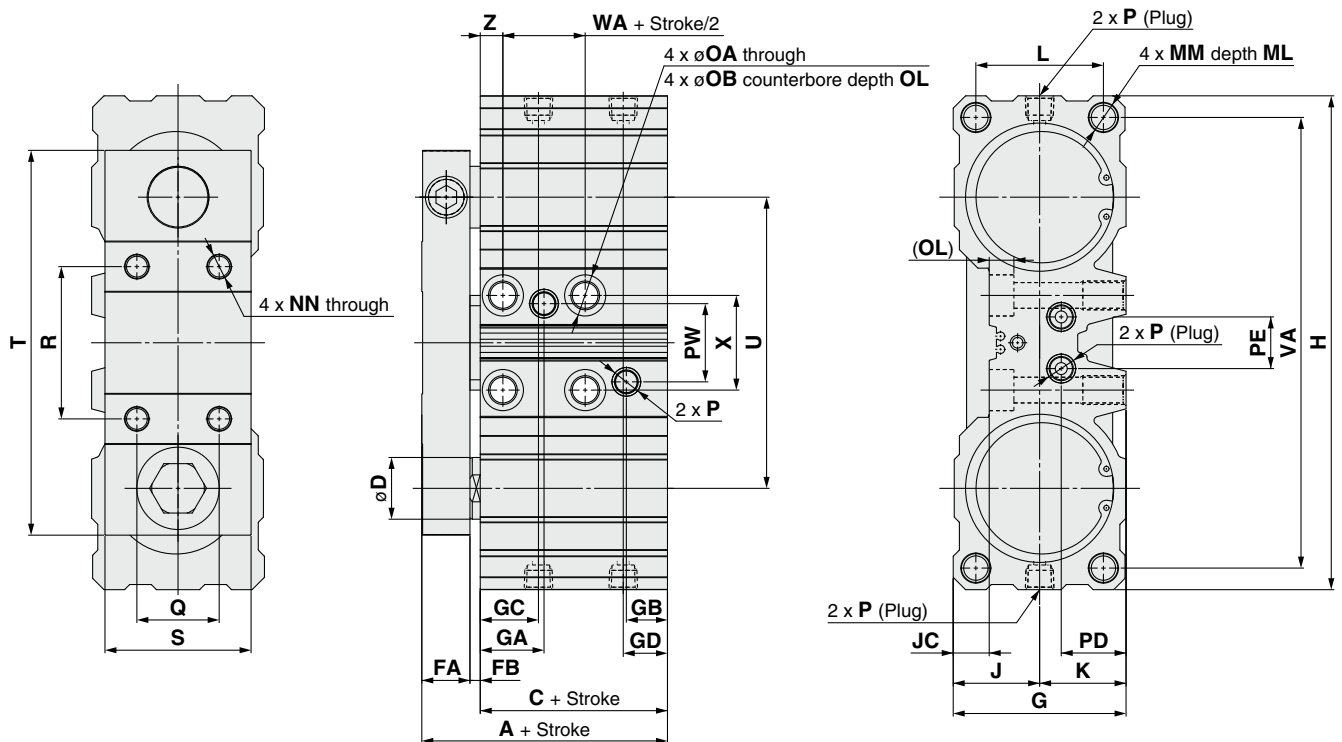
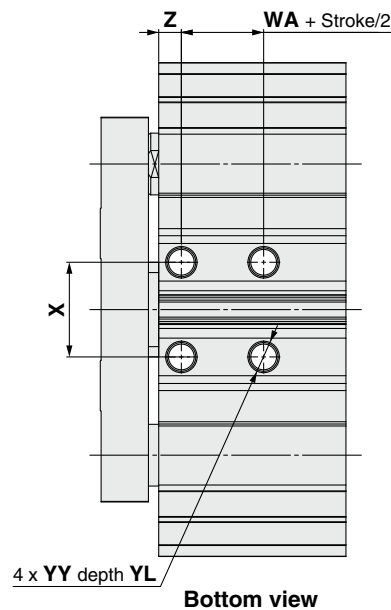

[mm]

Bore size	Standard stroke	A	C	D	FA	FB	G	GA	GB	GC	GD	H	J	JC	K	L	MM	ML	NN
$\varnothing 80$ ( $\varnothing 56 \times 2$ )	25, 50, 100 150, 200	85.5	62	25	19.5	4	69	28.5	20.5	25	22	202	34.5	15.5	34.5	50	M12 x 1.75	30	M10 x 1.5
$\varnothing 100$ ( $\varnothing 71 \times 2$ )		94.5	66	30	23.5	5	84	31	20	28.5	21.5	240	42	17.5	42	62	M14 x 2	35	M12 x 1.75

Bore size	OA	OB	OL	P			PD	PE	PW	Q	R	S	T	U	VA	WA	X	YY	YL	Z
				Nil	TN	TF														
$\varnothing 80$ ( $\varnothing 56 \times 2$ )	10.6	17.5	10	Rc1/4	NPT1/4	G1/4	24.5	23	37	38	64	55	155	118	184	25.5	42	M12 x 1.75	18	9.5
$\varnothing 100$ ( $\varnothing 71 \times 2$ )	12.5	20	12	Rc1/4	NPT1/4	G1/4	31.5	25	38	40	74	71	187	141.5	219	27.5	46	M14 x 2	21	11

# JMGP Series Auto Switch Mounting

## Auto Switch Proper Mounting Position (Detection at stroke end) and Mounting Height

D-M9□/M9□V  
D-M9□W/M9□WV  
D-M9□A/M9□AV

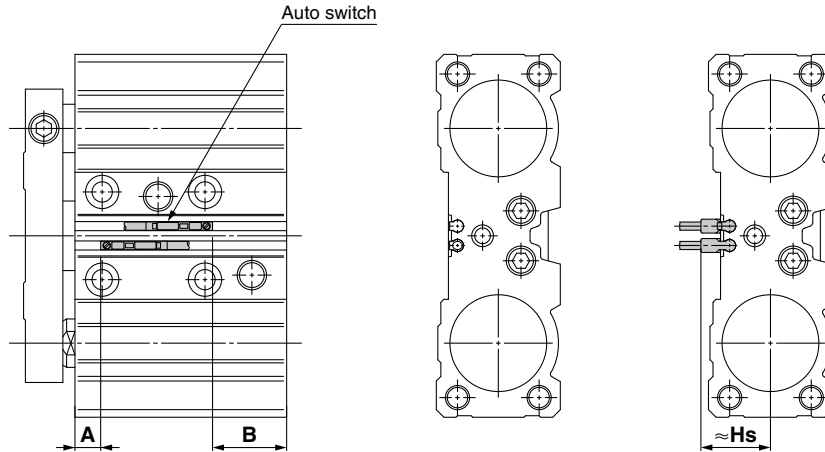

Auto Switch Proper Mounting Position [mm]

Auto switch model	D-M9□ D-M9□V D-M9□W D-M9□WV D-M9□A D-M9□AV	
	A	B
Bore size		
ø12 (ø10 x 2)	10.0	2.5
ø16 (ø12 x 2)	10.0	2.5
ø20 (ø16 x 2)	9.5	6.0
ø25 (ø20 x 2)	9.5	6.5
ø32 (ø25 x 2)	9.5	8.5
ø40 (ø32 x 2)	8.5	16.5
ø50 (ø40 x 2)	8.5	23.0
ø63 (ø45 x 2)	8.5	27.5
ø80 (ø56 x 2)	8.5	41.5
ø100 (ø71 x 2)	7.5	46.5

Auto Switch Mounting Height [mm]

Auto switch model	D-M9□V D-M9□WV D-M9□AV
	Hs
Bore size	
ø12 (ø10 x 2)	14.0
ø16 (ø12 x 2)	14.0
ø20 (ø16 x 2)	14.0
ø25 (ø20 x 2)	14.0
ø32 (ø25 x 2)	—
ø40 (ø32 x 2)	23.5
ø50 (ø40 x 2)	—
ø63 (ø45 x 2)	—
ø80 (ø56 x 2)	—
ø100 (ø71 x 2)	—

\* Adjust the auto switch after confirming the operating conditions in the actual setting.

## Minimum Stroke for Auto Switch Mounting

Auto switch model	Number of auto switches	Bore size [mm]									
		ø12 (ø10 x 2)	ø16 (ø12 x 2)	ø20 (ø16 x 2)	ø25 (ø20 x 2)	ø32 (ø25 x 2)	ø40 (ø32 x 2)	ø50 (ø40 x 2)	ø63 (ø45 x 2)	ø80 (ø56 x 2)	ø100 (ø71 x 2)
D-M9□V	1	5									
	2	5									
D-M9□	1	5*1			5						
	2	10*1	10								
D-M9□W	1	5*2									
	2	10*2	10								
D-M9□WV D-M9□AV	1	5*2									
	2	10									
D-M9□A	1	5*2									
	2	10*2									

\*1 Confirm that it is possible to secure the min. bending radius of 10 mm of the auto switch lead wire before use.

\*2 Confirm that it is possible to securely set the auto switch(es) within the range of indicator green light ON range before use.  
For the in-line entry type, also consider \*1 shown above.

## Operating Range

Auto switch model	Bore size [mm]									
	ø12 (ø10 x 2)	ø16 (ø12 x 2)	ø20 (ø16 x 2)	ø25 (ø20 x 2)	ø32 (ø25 x 2)	ø40 (ø32 x 2)	ø50 (ø40 x 2)	ø63 (ø45 x 2)	ø80 (ø56 x 2)	ø100 (ø71 x 2)
D-M9□/M9□V D-M9□W/M9□WV D-M9□A/M9□AV	3.5	3	4	4	4	4	4	4	4	4

\* Values which include hysteresis are for reference purposes only. They are not a guarantee (assuming approximately ±30% dispersion) and may change substantially depending on the ambient environment.

## Auto Switch Mounting

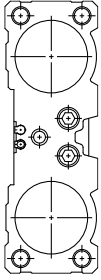
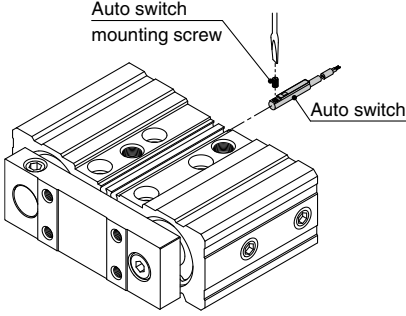
Applicable auto switches	<b>D-M9□/M9□V</b> <b>D-M9□W/M9□WV</b> <b>D-M9□A/M9□AV</b>				
Bore size	<b>ø12 (ø10 x 2) to ø100 (ø71 x 2)</b>				
Auto switch mounting surface	Surfaces with auto switch mounting slot 				
Mounting of auto switch	 <ul style="list-style-type: none"> <li>When tightening the auto switch mounting screw, use a watchmaker's screwdriver with a handle diameter of 5 to 6 mm.</li> </ul> <p><b>Tightening Torque for Auto Switch Mounting Screw</b> [N·m]</p> <table border="1"> <thead> <tr> <th>Auto switch model</th> <th>Tightening torque</th> </tr> </thead> <tbody> <tr> <td><b>D-M9□(V)</b> <b>D-M9□W(V)</b> <b>D-M9□A(V)</b></td> <td>0.05 to 0.15</td> </tr> </tbody> </table>	Auto switch model	Tightening torque	<b>D-M9□(V)</b> <b>D-M9□W(V)</b> <b>D-M9□A(V)</b>	0.05 to 0.15
Auto switch model	Tightening torque				
<b>D-M9□(V)</b> <b>D-M9□W(V)</b> <b>D-M9□A(V)</b>	0.05 to 0.15				

## Caution on Proximity Installation

When cylinders are adjacent to one another as shown in the figure below, provide a space between them of at least, the amount shown in the table below.

If the space is not sufficient, the magnets in adjacent cylinders may cause the auto switches to malfunction.

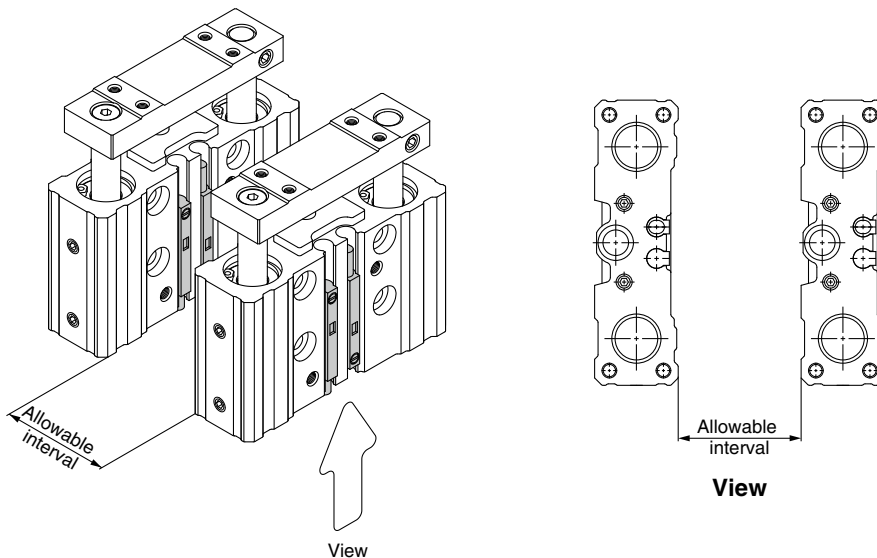

Bore size	Allowable interval [mm]
<b>ø12 (ø10 x 2)</b>	15
<b>ø16 (ø12 x 2)</b>	15
<b>ø20 (ø16 x 2)</b>	15
<b>ø25 (ø20 x 2)</b>	10
<b>ø32 (ø25 x 2)</b>	5
<b>ø40 (ø32 x 2)</b>	0
<b>ø50 (ø40 x 2)</b>	0
<b>ø63 (ø45 x 2)</b>	0
<b>ø80 (ø56 x 2)</b>	0
<b>ø100 (ø71 x 2)</b>	0

# Prior to Use

## Auto Switch Connections and Examples

### Sink Input Specifications

#### 3-wire, NPN

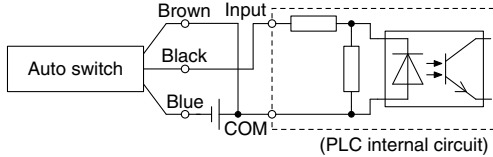

#### 2-wire

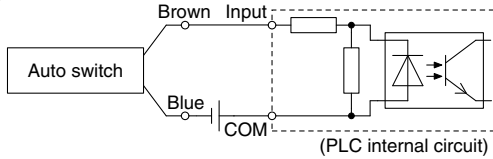

### Source Input Specifications

#### 3-wire, PNP

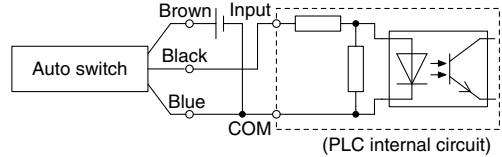

#### 2-wire

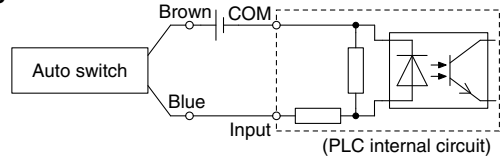

Connect according to the applicable PLC input specifications, as the connection method will vary depending on the PLC input specifications.

### Examples of AND (Series) and OR (Parallel) Connections

\* When using solid state auto switches, ensure the application is set up so the signals for the first 50 ms are invalid. Depending on the operating environment, the product may not operate properly.

#### 3-wire AND connection for NPN output (Using relays)

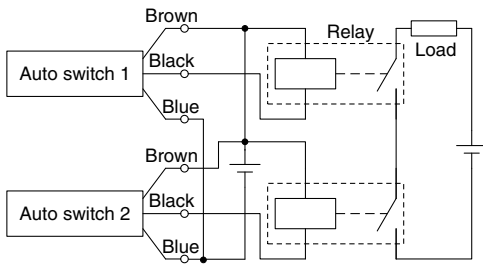

#### (Performed with auto switches only)

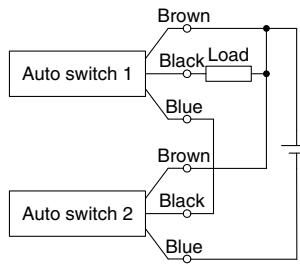

#### 3-wire OR connection for NPN output

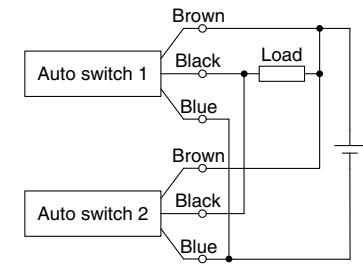

#### 3-wire AND connection for PNP output (Using relays)

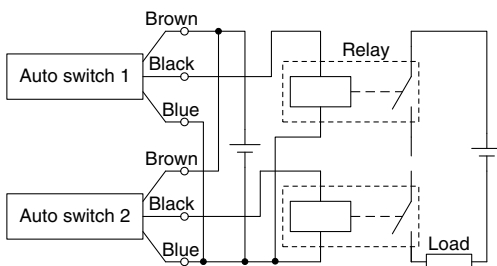

#### (Performed with auto switches only)

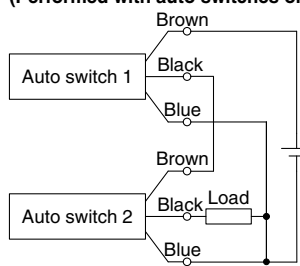

#### 3-wire OR connection for PNP output

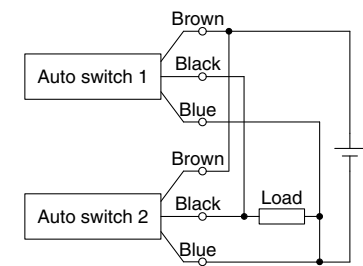

#### 2-wire AND connection

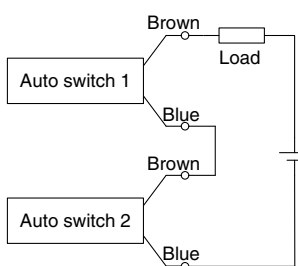

When two auto switches are connected in series, a load may malfunction because the load voltage will decline when in the ON state. The indicator lights will light up when both of the auto switches are in the ON state. Auto switches with a load voltage less than 20 V cannot be used. Please contact SMC if using AND connection for a heat-resistant solid state auto switch or a trimmer switch.

Example) Load voltage at ON  
 Power supply voltage: 24 VDC  
 Internal voltage drop: 4 V  
 Load voltage at ON = Power supply voltage –  
 Internal voltage drop x 2 pcs.  
 = 24 V – 4 V x 2 pcs.  
 = 16 V

#### 2-wire OR connection

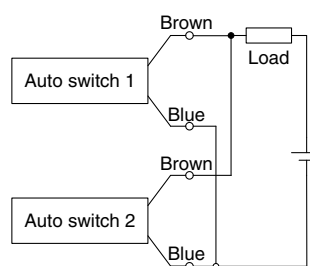

(Solid state)  
 When two auto switches are connected in parallel, malfunction may occur because the load voltage will increase when in the OFF state.

(Reed)  
 Because there is no current leakage, the load voltage will not increase when turned OFF. However, depending on the number of auto switches in the ON state, the indicator lights may sometimes grow dim or not light up, due to the dispersion and reduction of the current flowing to the auto switches.

Example) Load voltage at OFF  
 Leakage current: 1 mA  
 Load impedance: 3 kΩ  
 Load voltage at OFF = Leakage current x 2 pcs. x  
 Load impedance  
 = 1 mA x 2 pcs. x 3 kΩ  
 = 6 V



# Related Product

For the  $\phi 12$  and  $\phi 16$  JMGP

RoHS

## Speed Controller with One-touch Fitting

Elbow Type for M3 AS12□1F-M3-□A-X790

Metric size (Color: Light gray)



Inch size (Color: Orange)

### Specifications

Fluid	Air
Proof pressure	1.5 MPa
Max. operating pressure	1 MPa
Min. operating pressure	0.1 MPa
Ambient and fluid temperatures	-5 to 60°C (No freezing)
Applicable tubing material	Nylon, Soft nylon, Polyurethane*1, FEP, PFA

\*1 Use caution at the max. operating pressure when using soft nylon or polyurethane tubing. (Refer to the Web Catalog for details.)

### Flow Rate and Sonic Conductance

Model		AS12□1F-M3-□
Tubing O.D.	Metric size	$\phi 2$ , $\phi 3.2$ , $\phi 4$ , $\phi 6$
C values: Sonic conductance $\text{dm}^3/(\text{s}\cdot\text{bar})$	Free flow	0.07
	Controlled flow	0.07
b values: Critical pressure ratio	Free flow	0.3
	Controlled flow	0.2

\* C and b values are for controlled flow with the needle fully open and free flow with the needle fully closed.

### How to Order

**AS 1 2 0 1 F - M3 - 06 A - X790**

Body size  
1 M3 x 0.5

Port size  
M3 M3 x 0.5

Type  
2 Elbow

Control type\*1  
0 Meter-out  
1 Meter-in

\*1 Meter-out and meter-in types can be visually identified by the color of the knob.  
Meter-out: Gray  
Meter-in: Light blue

Push-lock type

Applicable tubing O.D.

Metric size*1	Inch size*1
02 $\phi 2^*3$	01 $\phi 1/8''$
23 $\phi 3.2^*2$	03 $\phi 5/32''$
04 $\phi 4$	
06 $\phi 6$	

\*1 Metric size: Light gray  
Inch size: Orange

\*2 Use  $\phi 1/8''$  tubing.

\*3 Only polyurethane tubing is applicable for  $\phi 2$ .

### Needle Valve/Flow Rate Characteristics

AS1201F-M3-□

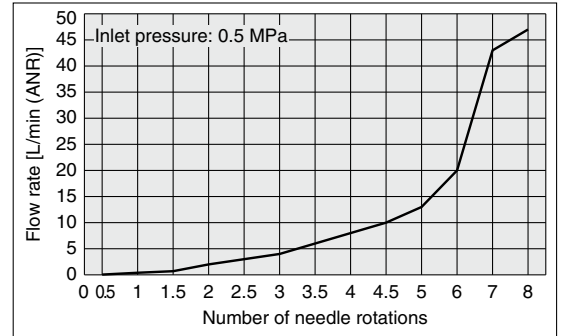

### Dimensions

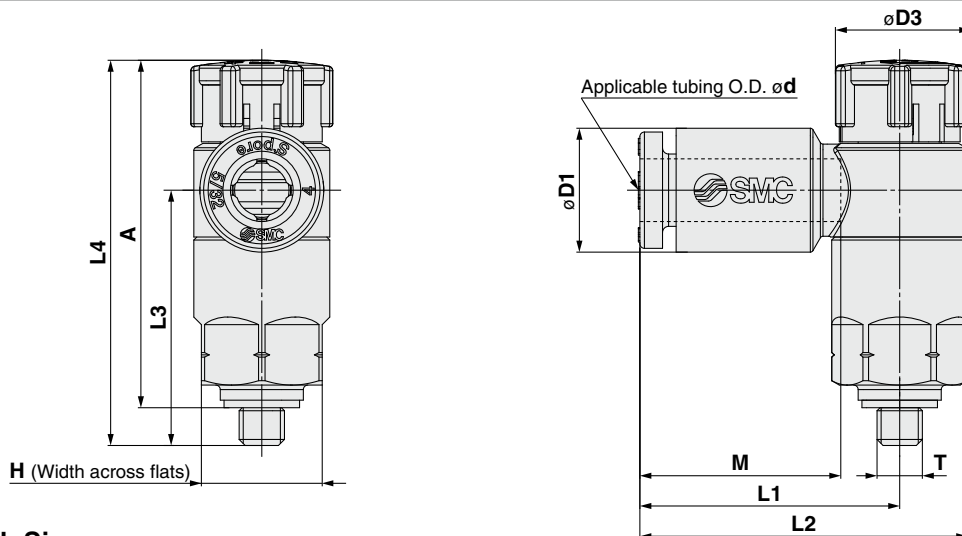

### Metric Size/Inch Size

Model	d	T	H	D1	D3	L1	L2	L3	L4*1		A*2		M	Weight [g]
									Unlocked	Locked	Unlocked	Locked		
AS12□1F-M3-02A-X790	2	M3 x 0.5	8	5.8	9.4	15.8	20.3	16.9	26.5	25.4	23.5	22.4	11.9	5
AS12□1F-M3-23A-X790	3.2			7.2		17.2	21.7							
AS12□1F-M3-04A-X790	4			8.2		18.6	23.1							
AS12□1F-M3-06A-X790	6			10.4		17.2	21.7							
AS12□1F-M3-01A-X790	1/8"			7.2										
AS12□1F-M3-03A-X790	5/32"			8.2										

\*1 Reference dimensions

\*2 Reference dimensions of threads after installation



## JMGP Series

# Specific Product Precautions 1

Be sure to read this before handling the products. Refer to the back cover for safety instructions. For actuator and auto switch precautions, refer to the “Handling Precautions for SMC Products” and the “Operation Manual” on the SMC website: <https://www.smcworld.com>

### Mounting

#### ⚠ Warning

##### 1. Never place your hands or fingers between the plate and the body.

Be very careful to prevent your hands or fingers from getting caught in the gap between the cylinder body and the plate when air is applied.

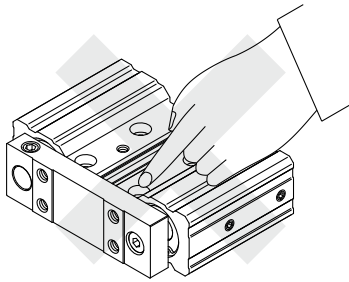

#### ⚠ Caution

##### 1. Use cylinders within the piston speed range.

An orifice is set for this cylinder, but the piston speed may exceed the operating range if the speed controller is not used. If the cylinder is used outside the operating speed range, it may cause damage to the cylinder and shorten the service life. Adjust the speed by installing the speed controller and use the cylinder within the limited range.

##### 2. Pay attention to the operating speed when the product is mounted vertically.

When using the product in the vertical direction, if the load factor is large, the operating speed can be faster than the control speed of the speed controller (i.e. quick extension). In such cases, it is recommended to use a dual speed controller.

##### 3. Do not scratch or gouge the sliding portion of the piston rod.

Damaged seals, etc., will result in leakage or malfunction.

##### 4. Do not dent or scratch the mounting surface of the body and the plate.

The flatness of the mounting surface may not be maintained, which would cause an increase in sliding resistance.

##### 5. Make sure that the cylinder mounting surface has a flatness of 0.05 mm or less.

If the flatness of the workpieces and brackets mounted on the plate is not appropriate, sliding resistance may increase. If it is difficult to maintain a flatness of 0.05 mm or less, put a thin shim ring (provided by the customer) between the plate and the workpiece mounting surface to prevent the sliding resistance from increasing.

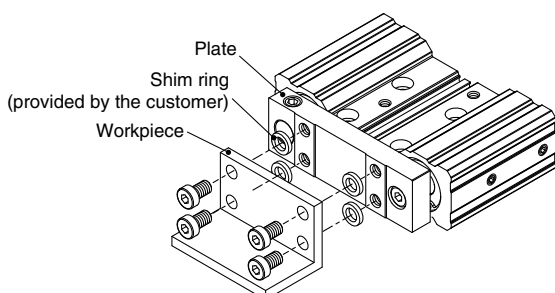

### Mounting

#### ⚠ Caution

##### 6. Be sure that the piston rods are retracted when mounting workpieces on the plate.

If workpieces are mounted on the plate when the piston rods are extended, it can lead to distortion of the piston rods, resulting in a malfunction.

##### 7. Rear of cylinder

For rear mounting, make a hole to the mounting base of the customer for hexagon socket head cap screws.

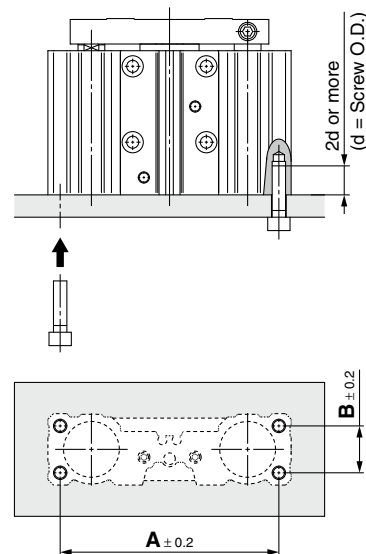

Bore size	A [mm]	B [mm]	Hexagon socket head cap screw
ø12 (ø10 x 2)	52	11	M3 x 0.5
ø16 (ø12 x 2)	57	11	M4 x 0.7
ø20 (ø16 x 2)	75	14	M4 x 0.7
ø25 (ø20 x 2)	84	17	M5 x 0.8
ø32 (ø25 x 2)	98	21	M6 x 1.0
ø40 (ø32 x 2)	107	27	M8 x 1.25
ø50 (ø40 x 2)	135	37	M8 x 1.25
ø63 (ø45 x 2)	146	40	M10 x 1.5
ø80 (ø56 x 2)	184	50	M12 x 1.75
ø100 (ø71 x 2)	219	62	M14 x 2

##### 8. Depending on the system configuration selected, the specified speed may not be satisfied.

### Other

#### ⚠ Caution

This product should not be used as a stopper.



## JMGP Series

# Specific Product Precautions 2

Be sure to read this before handling the products. Refer to the back cover for safety instructions. For actuator and auto switch precautions, refer to the “Handling Precautions for SMC Products” and the “Operation Manual” on the SMC website: <https://www.smcworld.com>

### Piping

## ⚠ Caution

Change the plug position for the piping port according to the usage conditions. When changing the port position, reassemble using the removed plug or order a replacement plug from the table below. If reusing the removed plug, apply sealant, etc., before reassembly. Clear any foreign matter adhered to the port the plug was removed from before piping.

### Plug Part Number

Bore size	Part number	Port thread type	Quantity*1
ø12 (ø10 x 2) ø16 (ø12 x 2)	P-M3	M3	8
ø20 (ø16 x 2) ø25 (ø20 x 2) ø32 (ø25 x 2)	P-M5	M5	8
ø40 (ø32 x 2) ø50 (ø40 x 2) ø63 (ø45 x 2)	P-R1	Rc1/8	8
	P-N1	NPT1/8	8
	P-G1	G1/8	8
ø80 (ø56 x 2) ø100 (ø71 x 2)	P-R2	Rc1/4	8
	P-N2	NPT1/4	8
	P-G2	G1/4	8

\*1 1 set includes 8 pieces.

**In addition, when reassembling the replacement plug, apply grease slightly to the whole circumference of the female thread of the port. (M3, M5, and G threads)**

Use SMC's recommended grease.

Grease pack part number: GR-S-010 (10 g)

### M3, M5, Rc port, NPT port

Use the correct tightening torques listed below.

Connection thread (plug) size	Proper tightening torque [N·m]	Dimension “a”
M3	0.65 to 0.75	—
M5	3.2 to 3.8	—
1/8	3.5 to 5.5	1 mm or less
1/4	6.5 to 12	1 mm or less

### G port

Screw in the plug to the surface of the body (dimension “a” in the drawing) by checking visually instead of using the tightening torque shown above.

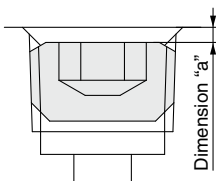



After changing the position of the plug, be sure to confirm that there is no air leakage from the plug before operating.

## Safety Instructions

These safety instructions are intended to prevent hazardous situations and/or equipment damage. These instructions indicate the level of potential hazard with the labels of “**Caution**,” “**Warning**” or “**Danger**.” They are all important notes for safety and must be followed in addition to International Standards (ISO/IEC)\*1), and other safety regulations.

 **Caution:** **Caution** indicates a hazard with a low level of risk which, if not avoided, could result in minor or moderate injury.

 **Warning:** **Warning** indicates a hazard with a medium level of risk which, if not avoided, could result in death or serious injury.

 **Danger :** **Danger** indicates a hazard with a high level of risk which, if not avoided, will result in death or serious injury.

\*1) ISO 4414: Pneumatic fluid power – General rules relating to systems.  
ISO 4413: Hydraulic fluid power – General rules relating to systems.  
IEC 60204-1: Safety of machinery – Electrical equipment of machines.  
(Part 1: General requirements)  
ISO 10218-1: Manipulating industrial robots – Safety.  
etc.

### Warning

#### 1. The compatibility of the product is the responsibility of the person who designs the equipment or decides its specifications.

Since the product specified here is used under various operating conditions, its compatibility with specific equipment must be decided by the person who designs the equipment or decides its specifications based on necessary analysis and test results. The expected performance and safety assurance of the equipment will be the responsibility of the person who has determined its compatibility with the product. This person should also continuously review all specifications of the product referring to its latest catalog information, with a view to giving due consideration to any possibility of equipment failure when configuring the equipment.

#### 2. Only personnel with appropriate training should operate machinery and equipment.

The product specified here may become unsafe if handled incorrectly. The assembly, operation and maintenance of machines or equipment including our products must be performed by an operator who is appropriately trained and experienced.

#### 3. Do not service or attempt to remove product and machinery/equipment until safety is confirmed.

1. The inspection and maintenance of machinery/equipment should only be performed after measures to prevent falling or runaway of the driven objects have been confirmed.
2. When the product is to be removed, confirm that the safety measures as mentioned above are implemented and the power from any appropriate source is cut, and read and understand the specific product precautions of all relevant products carefully.
3. Before machinery/equipment is restarted, take measures to prevent unexpected operation and malfunction.

#### 4. Contact SMC beforehand and take special consideration of safety measures if the product is to be used in any of the following conditions.

1. Conditions and environments outside of the given specifications, or use outdoors or in a place exposed to direct sunlight.
2. Installation on equipment in conjunction with atomic energy, railways, air navigation, space, shipping, vehicles, military, medical treatment, combustion and recreation, or equipment in contact with food and beverages, emergency stop circuits, clutch and brake circuits in press applications, safety equipment or other applications unsuitable for the standard specifications described in the product catalog.
3. An application which could have negative effects on people, property, or animals requiring special safety analysis.
4. Use in an interlock circuit, which requires the provision of double interlock for possible failure by using a mechanical protective function, and periodical checks to confirm proper operation.

### Caution

#### 1. The product is provided for use in manufacturing industries.

The product herein described is basically provided for peaceful use in manufacturing industries.  
If considering using the product in other industries, consult SMC beforehand and exchange specifications or a contract if necessary.  
If anything is unclear, contact your nearest sales branch.

## Limited warranty and Disclaimer/ Compliance Requirements

The product used is subject to the following “Limited warranty and Disclaimer” and “Compliance Requirements”.

Read and accept them before using the product.

### Limited warranty and Disclaimer

1. The warranty period of the product is 1 year in service or 1.5 years after the product is delivered, whichever is first.\*2)  
Also, the product may have specified durability, running distance or replacement parts. Please consult your nearest sales branch.
2. For any failure or damage reported within the warranty period which is clearly our responsibility, a replacement product or necessary parts will be provided.  
This limited warranty applies only to our product independently, and not to any other damage incurred due to the failure of the product.
3. Prior to using SMC products, please read and understand the warranty terms and disclaimers noted in the specified catalog for the particular products.

#### \*2) Vacuum pads are excluded from this 1 year warranty.

A vacuum pad is a consumable part, so it is warranted for a year after it is delivered.  
Also, even within the warranty period, the wear of a product due to the use of the vacuum pad or failure due to the deterioration of rubber material are not covered by the limited warranty.

### Compliance Requirements

1. The use of SMC products with production equipment for the manufacture of weapons of mass destruction (WMD) or any other weapon is strictly prohibited.
2. The exports of SMC products or technology from one country to another are governed by the relevant security laws and regulations of the countries involved in the transaction. Prior to the shipment of a SMC product to another country, assure that all local rules governing that export are known and followed.

### Caution

#### SMC products are not intended for use as instruments for legal metrology.

Measurement instruments that SMC manufactures or sells have not been qualified by type approval tests relevant to the metrology (measurement) laws of each country. Therefore, SMC products cannot be used for business or certification ordained by the metrology (measurement) laws of each country.

#### Revision History

<b>Edition B</b>	* Bore sizes $\phi 40$ to $\phi 63$ have been added. * The number of pages has been increased from 12 to 16.	TR
<b>Edition C</b>	* Bore sizes $\phi 80$ and $\phi 100$ have been added. * Port thread types NPT and G have been added.	UR
<b>Edition D</b>	* The contents of the cover and feature pages have been changed. (Comparison with the CXS series) * The number of pages has been increased from 16 to 20.	AT

 **Safety Instructions** Be sure to read the “Handling Precautions for SMC Products” (M-E03-3) and “Operation Manual” before use.

## SMC Corporation

Akihara UDX 15F,  
4-14-1, Sotokanda, Chiyoda-ku, Tokyo 101-0021, JAPAN  
Phone: 03-5207-8249 Fax: 03-5298-5362  
<https://www.smcworld.com>  
© 2022 SMC Corporation All Rights Reserved

Specifications are subject to change without prior notice and any obligation on the part of the manufacturer.

D-G