

Circulating Fluid Temperature Controller

Low GWP Refrigerant Chiller



New



Refrigerated Thermo-chiller

SEMI Standard
S2, S8, F47

GWP:146^{*1}

EU refrigerant regulations: GWP150 or more
US refrigerant regulations: GWP700 or more
California, US refrigerant regulations: GWP750 or more

*1 Regulation (EU) 2024/573, AIM Act 40 CFR Part 84

Environmentally friendly

R454C as refrigerant

Not available for air transport

*More effective energy-saving is achieved through use of a **DC inverter compressor** and an **inverter pump**.*



| | |
|---------------------------|--|
| Type of circulating fluid | Fluorinated fluids, Ethylene glycol aqueous solution |
| Temperature range setting | -20 to 90°C |
| Cooling capacity | 10 kW |
| Temperature stability | ±0.1°C |

HRZF Series



CAT.ES40-81A^A

CONTENTS

HRZF Series



Circulating Fluid Temperature Controller

Low GWP Refrigerant Chiller Refrigerated Thermo-chiller HRZF Series

● Thermo-chiller

Pump Inverter and Compressor Inverter Type

| | |
|---------------------------------------|------|
| How to Order | p. 2 |
| Specifications | p. 3 |
| Cooling Capacity | p. 4 |
| Heating Capacity | p. 4 |
| Pump Capacity (Thermo-chiller Outlet) | p. 4 |
| Dimensions | p. 5 |

● Options

| | |
|--------------------------------------|------|
| Analog Communication | p. 6 |
| DeviceNet Communication | p. 6 |
| NPT Fitting | p. 6 |
| DI Control Kit | p. 6 |
| Circulating Fluid Automatic Recovery | p. 7 |

● Optional Accessories

| | |
|--|-------|
| ① Bypass Piping Set | p. 8 |
| ② Anti-quake Bracket | p. 8 |
| ③ 4-Port Manifold | p. 9 |
| ④ DI Filter | p. 9 |
| ⑤ Insulating Material for DI Filter | p. 9 |
| ⑥ 60% Ethylene Glycol Aqueous Solution | p. 10 |
| ⑦ Concentration Meter | p. 10 |

| | |
|------------------------------|-------|
| Specific Product Precautions | p. 11 |
|------------------------------|-------|

Low GWP Refrigerant Chiller



Thermo-chiller Pump Inverter and Compressor Inverter Type

SEMI

HRZF Series

RoHS

How to Order

HRZF 010 - W [] S - []

Cooling capacity

| | |
|-----|-------|
| 010 | 10 kW |
|-----|-------|

Circulating fluid type

| | |
|-----|--------------------------------------|
| Nil | Fluorinated fluids |
| 1 | 60% ethylene glycol aqueous solution |

Option

| | |
|-----|--------------------------------------|
| Nil | None |
| C | Analog communication |
| D | DeviceNet communication |
| N | NPT fitting |
| Y*1 | DI control kit |
| Z | Circulating fluid automatic recovery |

*1 Not equipped to the fluorinated fluid type.

Pump inverter and compressor inverter type

Specifications

| Model | | HRZF010-WS |
|---|----------------------|--|
| Channel/Cooling method | | 1 channel/Water-cooled refrigeration |
| Temperature control method | | PID control |
| Refrigerant | | R454C (HFO/HFC, GWP:146)*12 |
| Refrigerant charge | kg | 1.5 |
| Ambient temperature | °C | 10 to 35 |
| Ambient humidity*1 | %RH | 30 to 70 |
| Altitude | m | 1000 or less |
| Circulating fluid*2 | | Fully fluorinated fluid -20 to 40°C: Fluorinert™ FC-3283 GALDEN® HT135 20 to 90°C: Fluorinert™ FC-40 GALDEN® HT200 |
| Temperature range setting*1/Temperature stability*3 | | °C -20 to 90/±0.1 |
| Cooling capacity*4 (Under conditions below) | | kW 10 (4) |
| Circulating fluid temperature | | °C 20 (-10) |
| Facility water temperature | | °C 25 |
| Circulating fluid flow rate | | L/min 20 |
| Pump capacity*5 | | MPa 0.72 (at 20 L/min) With flow control function by pump inverter |
| Rated flow*6 | | L/min 20 |
| Flow display range | | L/min 0 to 50 |
| Flow range*7 | | L/min 10 to 40 |
| Discharge pressure display range | | MPa 0 to 1.5 |
| Tank | Main tank capacity*8 | L Approx. 15 |
| | Sub-tank capacity*9 | L Approx. 16 |
| Contact material for circulating fluid | | Stainless steel, EPDM, Copper brazing (Heat exchanger), Silicone, PPS, Fluororesin |
| Height difference between this product and customer's equipment | | m 10 or less |
| Outlet port size | | Rc3/4 (With plug) |
| Return port size | | Rc3/4 (With plug) |
| Drain port size | | Rc3/8 (With valve/plug) |
| Temperature | | °C 10 to 30 |
| Inlet pressure | | MPa 0.3 to 0.7 |
| Inlet-outlet pressure differential of facility water | | MPa 0.3 or more |
| Required flow rate*10 | | L/min 15 |
| Inlet port size | | Rc1/2 (With plug) |
| Outlet port size | | Rc1/2 (With plug) |
| Contact material for cooling water | | Stainless steel, EPDM, Copper brazing (Heat exchanger), Silicone, Brass, NBR |
| Voltage | | V 3-phase 200 VAC/200 to 208 ±10 [%] (50/60 Hz) |
| Max. operating current | | A 26 |
| Breaker capacity | | A 30 (Earth leakage breaker sensitivity current: 30 mA) |
| Communication function | | Contact input/output (D-sub 25P, Female connector) Serial RS-485 (D-sub 9P, Female connector) |
| External dimensions | | mm 380 x 870 x 950 |
| Weight*11 | | kg 165 ±5 |
| Compliant standards | | SEMI, CE/UKCA, UL |

*1 No condensation should be present.

*2 GALDEN® is a registered trademark, belonging to the Solvay Group or its corresponding owner. Fluorinert™ is a trademark of 3M.

*3 Value with a stable load without turbulence in the operating conditions.

*4 ① Facility water temperature: 25°C, ② Circulating fluid flow rate: Values at the rated circulating fluid flow rate. Values common for 50/60 Hz.

*5 The capacity at the thermo-chiller outlet when the circulating fluid temperature is 20°C

*6 The required flow rate for maintaining the cooling capacity or temperature stability. When used below the rated flow, use the individually sold, "Bypass Piping Set." (Refer to page 8).

*7 May not be able to control with the set value depending on the piping specification in the user side.

*8 Minimum volume required for operating only the thermo-chiller. (Circulating fluid temperature: 20°C, including the thermo-chiller's internal pipings or heat exchanger)

*9 Preliminary space volume without main tank capacity. Available for collecting the circulating fluid inside an external piping or for preliminary injection.

*10 Facility water temperature: 25°C. Flow rate required when the temperature setting is changed

*11 Weight in the dry state without circulating fluids

*12 R454C is a slightly flammable refrigerant. Avoid using this product in proximity to open flames.

HRZF Series

Specifications

| Model | | HRZF010-W1S | |
|----------------------------|---|--|--|
| Channel/Cooling method | | 1 channel/Water-cooled refrigeration | |
| Temperature control method | | PID control | |
| Refrigerant | | R454C (HFO/HFC, GWP:146) ^{*12} | |
| Refrigerant charge | | kg 1.5 | |
| Installation environment | Ambient temperature | °C 10 to 35 | |
| | Ambient humidity ^{*1} | %RH 30 to 70 | |
| | Altitude | m 1000 or less | |
| Circulating fluid system | Circulating fluid ^{*2} | 60% ethylene glycol aqueous solution | |
| | Temperature range setting ^{*1} / Temperature stability ^{*3} | °C -20 to 90/±0.1 | |
| | Cooling capacity ^{*4} (Under conditions below) | kW | 10 (4) |
| | | Circulating fluid temperature | °C 20 (-10) |
| | | Facility water temperature | °C 25 |
| | | Circulating fluid flow rate | L/min 20 |
| | Pump capacity ^{*5} | MPa 0.40 (at 20 L/min) With flow control function by pump inverter | |
| | Rated flow ^{*6} | L/min 20 | |
| | Flow display range | L/min 0 to 50 | |
| | Flow range ^{*7} | L/min 10 to 40 | |
| | Discharge pressure display range | MPa 0 to 1.5 | |
| | Tank | Main tank capacity ^{*8} | L Approx. 15 |
| | | Sub-tank capacity ^{*9} | L Approx. 16 |
| | Contact material for circulating fluid | | Stainless steel, EPDM, Copper brazing (Heat exchanger), Silicone, PPS, Fluororesin |
| | Height difference between this product and user's equipment | | m 10 or less |
| Outlet port size | | Rc3/4 (With plug) | |
| Return port size | | Rc3/4 (With plug) | |
| Drain port size | | Rc3/8 (With valve/plug) | |
| Cooling water system | Temperature | °C 10 to 30 | |
| | Inlet pressure | MPa 0.3 to 0.7 | |
| | Inlet-outlet pressure differential of facility water | MPa 0.3 or more | |
| | Required flow rate ^{*10} | L/min 15 | |
| | Inlet port size | Rc1/2 (With plug) | |
| | Outlet port size | Rc1/2 (With plug) | |
| | Contact material for cooling water | | Stainless steel, EPDM, Copper brazing (Heat exchanger), Silicone, Brass, NBR |
| Electrical system | Voltage | V 3-phase 200 VAC/200 to 208 ±10 [%] (50/60 Hz) | |
| | Max. operating current | A 25 | |
| | Breaker capacity | A 30 (Earth leakage breaker sensitivity current: 30 mA) | |
| | Communication function | Contact input/output (D-sub 25P, Female connector) Serial RS-485 (D-sub 9P, Female connector) | |
| External dimensions | mm 380 x 870 x 950 | | |
| Weight ^{*11} | kg 165 ±5 | | |
| Compliant standards | | SEMI, CE/UKCA, UL | |

*1 No condensation should be present.

*2 Dilute pure ethylene glycol with tap water. Additives such as preservatives cannot be used.

*3 Value with a stable load without turbulence in the operating conditions. It may be out of this range when a DI control kit (Option Y) is used or in some other operating conditions.

*4 ① Facility water temperature: 25°C, ② Circulating fluid flow rate: Values at the rated circulating fluid flow rate. Values common for 50/60 Hz.

*5 The capacity at the thermo-chiller outlet when the circulating fluid temperature is 20°C

*6 The required flow rate for maintaining the cooling capacity or temperature stability. When used below the rated flow, use the individually sold, "Bypass Piping Set." (Refer to page 8).

*7 May not be able to control with the set value depending on the piping specification in the user side.

*8 Minimum volume required for operating only the thermo-chiller. (Circulating fluid temperature: 20°C, including the thermo-chiller's internal pipings or heat exchanger)

*9 Preliminary space volume without main tank capacity. Available for collecting the circulating fluid inside an external piping or for preliminary injection.

*10 Facility water temperature: 25°C. Flow rate required when the temperature setting is changed

*11 Weight in the dry state without circulating fluids

*12 R454C is a slightly flammable refrigerant. Avoid using this product in proximity to open flames.

Cooling Capacity

HRZF010-WS/W1S

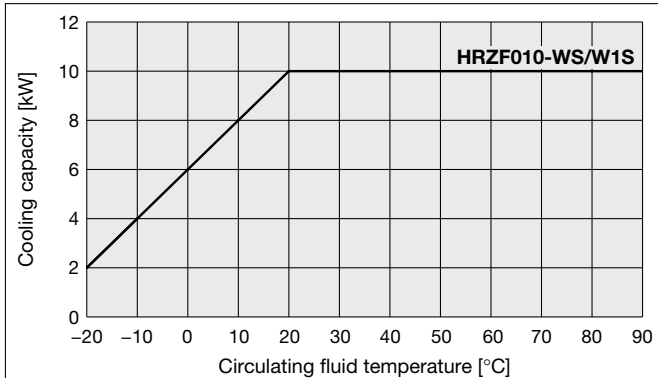

Heating Capacity

HRZF010-WS

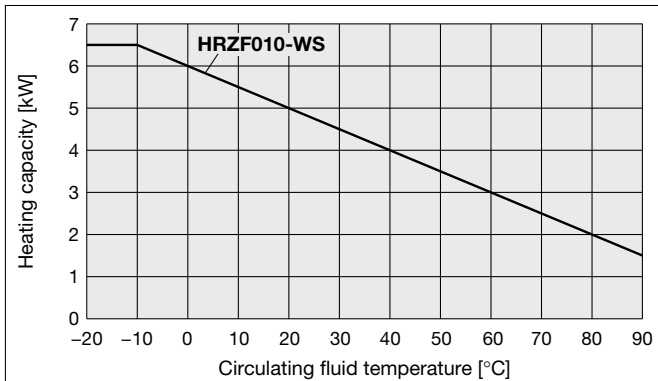

HRZF010-W1S

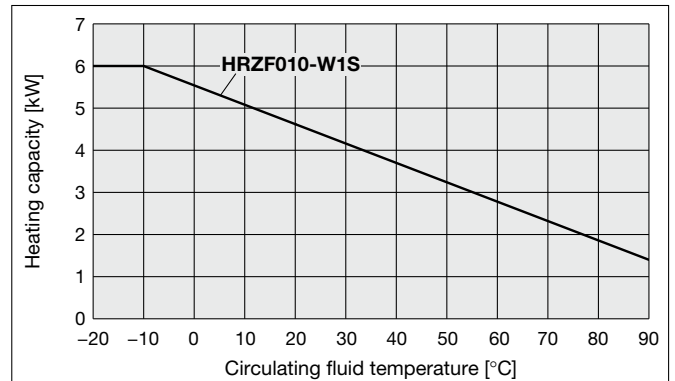

* When pump inverter is operating at frequency of 60 Hz (maximum).

Pump Capacity (Thermo-chiller Outlet)

HRZF010-WS

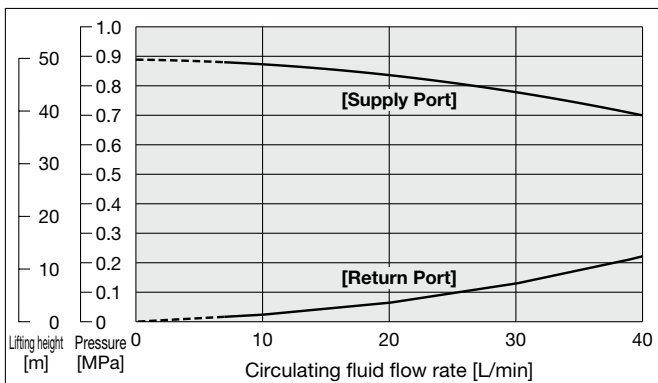

HRZF010-W1S

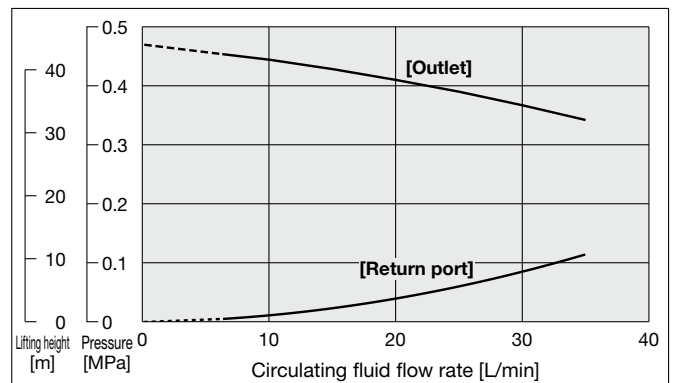

- * Circulating fluid temperature: 20°C
- When the operation of the inverter is at maximum frequency
- * When the circulating fluid flow is below 6 L/min, the in-built operation stop alarm will be activated. It is not possible to run the equipment. (common for all models)
- * With flow control function by inverter

HRZF Series

Dimensions

HRZF010-WS/HRZF010-W1S

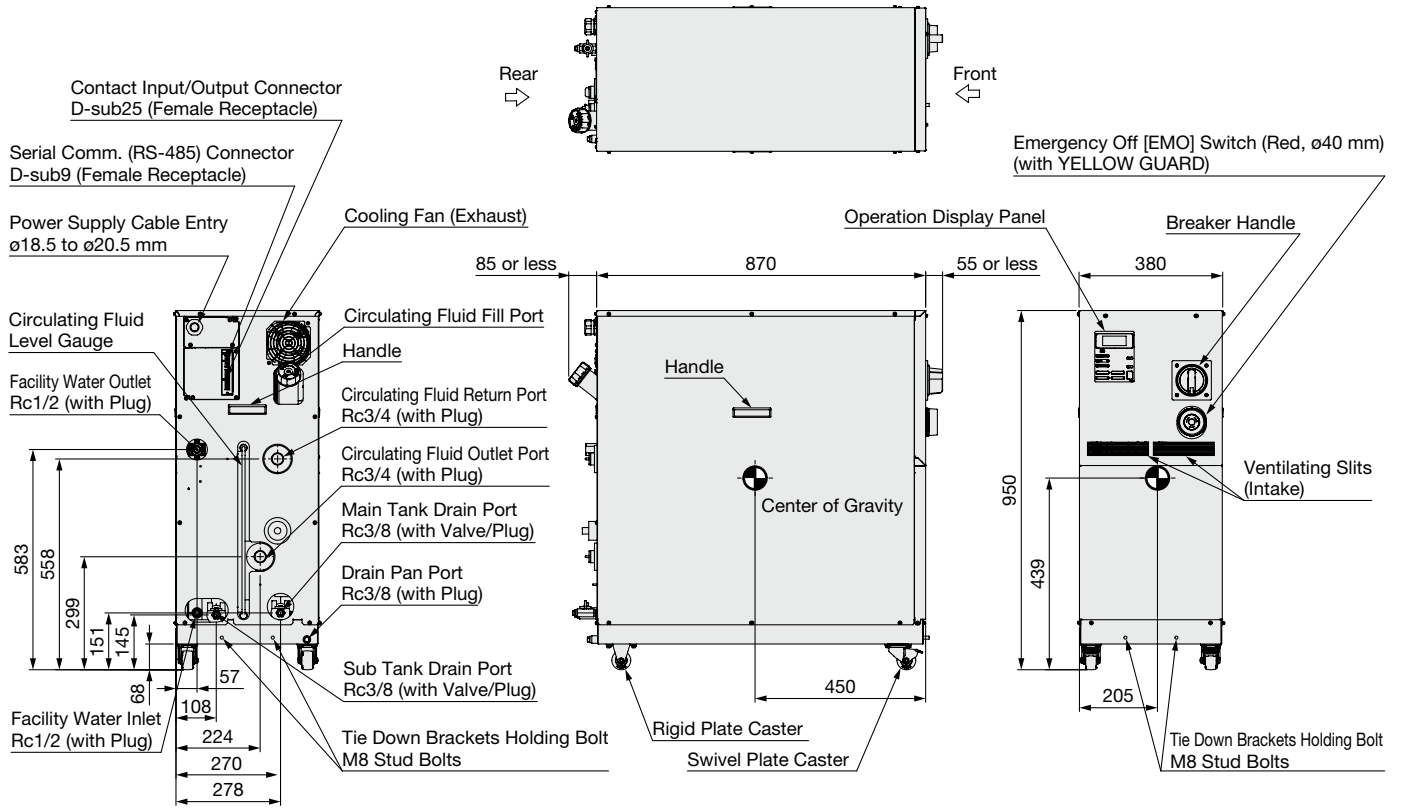

HRZF Series Options

* Options have to be selected when ordering the thermo-chiller. It is not possible to add them after purchasing the unit.

C Option symbol Analog Communication

HRZF010-□□-C

Analog communication

In addition to the standard contact input/output signal communication and the serial RS-485 communication, analog communication function can be added.

The analog communication function enables to write and read out the following items.

| | |
|---------------------------------------|---------------------------------------|
| <Writing> | <Readout> |
| Circulating fluid temperature setting | Circulating fluid present temperature |
| | Electric resistivity*1 |

*1 Only when the DI control kit (option Y) is selected.

Scaling voltage - circulating fluid temperature can be set arbitrarily by the customer.

For details, please refer to our "Communication Specifications" information.

D Option symbol DeviceNet Communication

HRZF010-□□-D

DeviceNet
communication

DeviceNet®

■Trademark
DeviceNet® is a registered trademark of ODVA, Inc.

In addition to the standard contact input/output signal communication and the serial RS-485 communication, DeviceNet function can be added. DeviceNet function enables to write and read out the following items.

| | |
|---|--|
| <Writing> | <Readout> |
| Run/Stop | Circulating fluid present temperature |
| Circulating fluid temperature setting | Circulating fluid flow |
| Circulating fluid automatic recovery start/stop*1 | Circulating fluid discharge pressure |
| | Electric resistivity*2 |
| | Alarm occurrence information |
| | Status (operating condition) information |

*1 Only when the circulating fluid automatic recovery function (Option Z) is selected.

*2 Only when the DI control kit (Option Y) is selected.

For details, please refer to our "Communication Specifications" information.

N Option symbol NPT Fitting

HRZF010-□□-N

NPT fitting

An adapter is included to change the connection parts of circulating fluid piping and facility water piping to NPT thread type. The adapter must be installed by the customer.

Y Option symbol DI Control Kit

HRZF010-W1S-Y

DI control kit

Select this option if you want to maintain the electric resistance ratio (DI level) of the circulating fluid at a certain level. However, some components have to be fitted by the customer. For details, refer to specification table for this option.

Please note that this is not applicable to the fluorinated liquid type.

| | | |
|--|-------|--|
| Allowable circulating fluid | — | 60% ethylene glycol aqueous solution |
| DI level display range | MΩ·cm | 0 to 20*1 |
| DI level set range | MΩ·cm | 0 to 2.0*2 |
| Solenoid valve hysteresis or control | MΩ·cm | 0 to 0.9 |
| DI level reduction alarm set range | MΩ·cm | 0 to 2.0 |
| DI circuit rated flow | L/min | Approx. 1.5 (When the circulating fluid flow rate on the user's system side is 20 L/min) |
| Contact material for circulating fluid*3 | — | FKM |

*1 The DI level display value is the value without temperature correction.

*2 The DI filter is needed to control the DI level. (SMC Part No.: HRZ-DF001)

Please purchase additionally because the DI filter is not included in this option. In addition, when the product is to be used outside of the 20 to 40°C range, be sure to purchase the insulating material for the DI filter (SMC part no.: HRZ-DF002) to prevent frostbite and burns.

*3 The additional contact material when this option is mounted

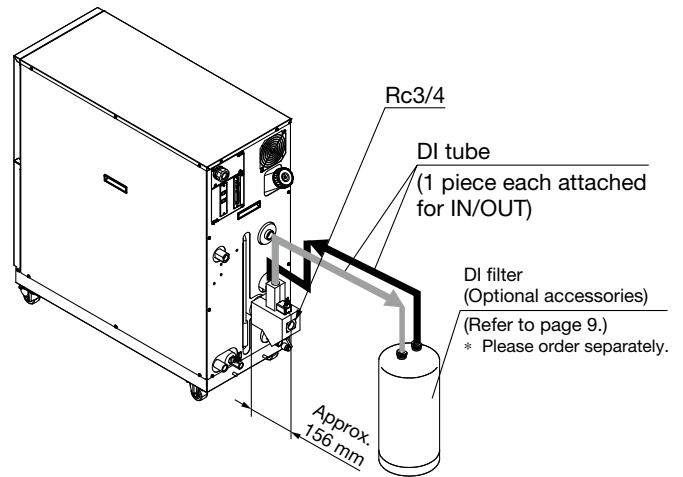

* Install the DI filter outside the thermo-chiller for piping. Secure the space for installing the DI filter on the rear side of the thermo-chiller.

* It may go outside of the temperature stability range of ±0.1°C when this option is used in some operating conditions.

HRZF Series

Z Option symbol

Circulating Fluid Automatic Recovery

HRZF010-W□S-Z

Circulating fluid
automatic recovery

Select this option for users who want to use the circulating fluid automatic recovery function. The automatic recovery function is a device which can recover the circulating fluid inside pipings into a sub-tank of the thermo-chiller by the external communication or operating display panel. Some components need to be fitted by the customer. For details, please refer to the "Product Specifications" information for these options.

| | | |
|---|--------------------|---|
| Circulating fluid recoverable volume*1 | L | 16 |
| Purge gas | — | Nitrogen gas, Compressed air*2 |
| Purge gas supply port | — | Self-align fitting for O.D. $\phi 8$ *3 |
| Purge gas supply pressure | MPa | 0.4 to 0.7 |
| Purge gas filtration | μm | 0.01 or less |
| Regulator set pressure | MPa | 0.15 to 0.3*3 |
| Recoverable circulating fluid temperature | $^{\circ}\text{C}$ | 10 to 30 |
| Recovery operation | — | Serial RS-485, contact input/output, or operation display panel*5 |
| Automatic recovery stop mode | sec | AUTO: After recovery completion, recovery is automatically stopped. (Factory setting) TIME: Recovery is continued for a set period of time. (Settable range: 1 to 600, Factory setting: 300) |
| Contact material for circulating fluid*6 | — | FKM |
| Height difference with the user's system side | m | 15 or less |

*1 This is the preliminary space volume when the liquid level is "High." The main tank capacity is not included. Do not allow the amount of fluid in the external piping to exceed the capacity of the circulating fluid recovery tank.

*2 Use compressed air with a dew point of -30°C or less. If compressed air with a high dew point is used, condensation will be generated in the tank when operated at low temperatures, which may result in cooling failure and other malfunctions. Be sure to confirm that there are no chemicals, synthetic oils that include organic solvents, salt, corrosive gases, etc., in the compressed air.

In addition, if a lubricator is used on the compressed air supply side, the bleed hole of the regulator may become clogged, resulting in malfunction.

*3 Before piping, clean inside the pipings with air blow, etc. Use the piping with no dust generation by purge gas. When using resin tube, where necessary, use insert fittings, etc. in order not to deform the tubings when connecting to self-align fittings.

*4 At the time of shipping from factory, it is set to 0.2 MPa.

*5 Refer to the thermo-chiller operation manual and the communication specifications manual for details.

*6 The additional contact material when this option is mounted

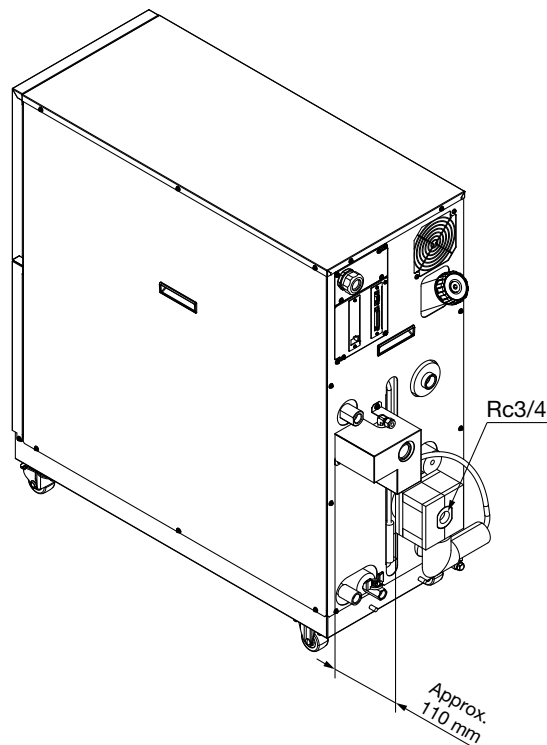

HRZF Series Optional Accessories

① Bypass Piping Set

* Necessary to be fitted by user.

When the circulating fluid goes below the rated flow, cooling capacity will be reduced and the temperature stability will be badly affected. In such a case, use the bypass piping set.

| Part no. | Applicable model |
|------------------|-----------------------|
| HRZ-BP002 | Common for all models |

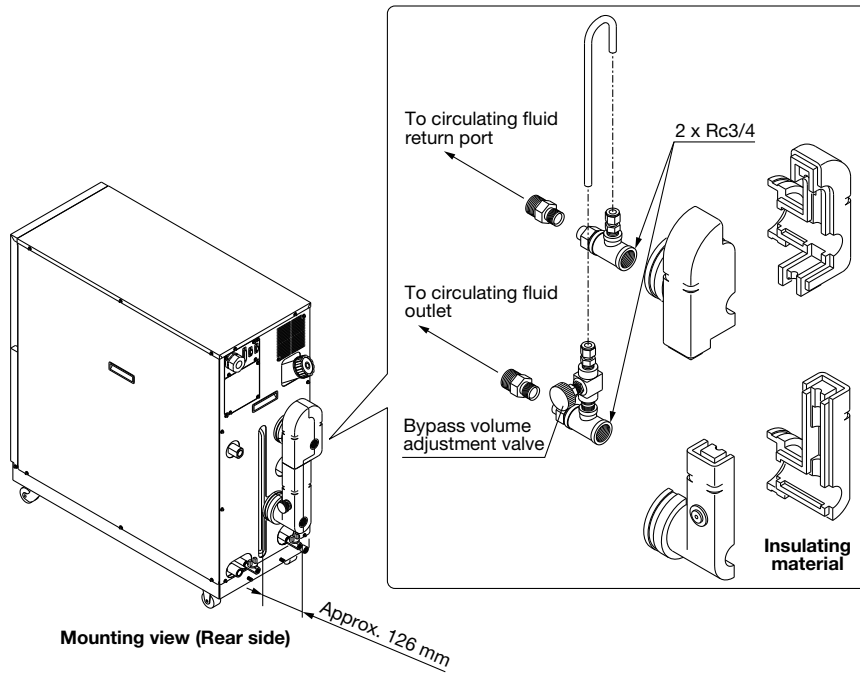

② Anti-quake Bracket

Bracket for earthquakes
Prepare the anchor bolts (M12) which are suited to the floor material by the customer.

| Part no. | Applicable model |
|------------------|-----------------------|
| HRZ-TK002 | Common for all models |

* 2 pieces per set (for 1 unit) (HRZ-TK002)

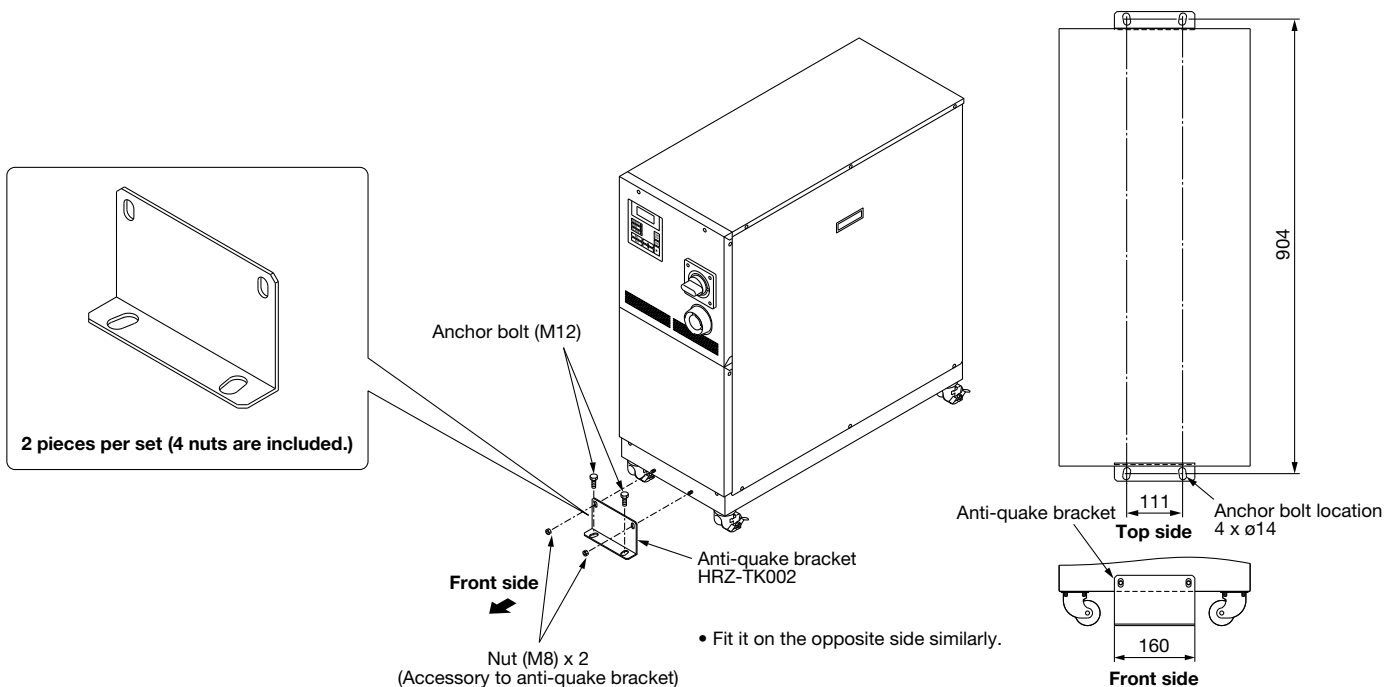

HRZF Series

③ 4-Port Manifold

4-branching the circulating fluid enables 4 temperature controls at the maximum with the 1 unit thermo-chiller.

| Part no. | Applicable model |
|------------------|-----------------------|
| HRZ-MA001 | Common for all models |

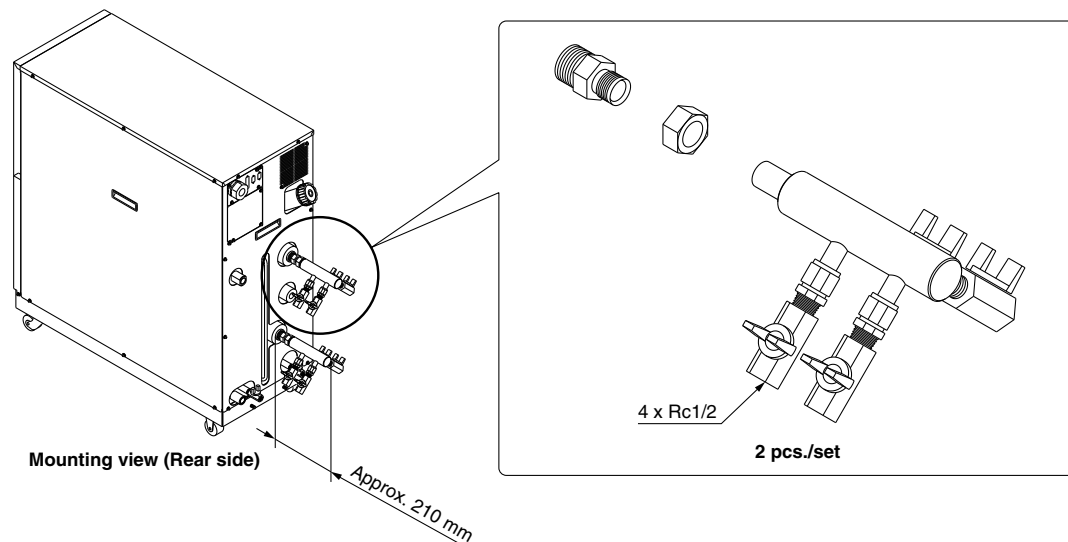

④ DI Filter

This is the ion replacement resin to maintain the electric resistivity of the circulating fluid. Users who selected the DI control kit (Option Y) need to purchase the DI filter separately.

| Part no. | Applicable model |
|------------------|------------------|
| HRZ-DF001 | HRZF010-W1S-Y |

* The DI filters are consumable. Depending on the status (electric resistivity set value, circulating fluid temperature, piping volume, etc.), product life cycles will vary accordingly.

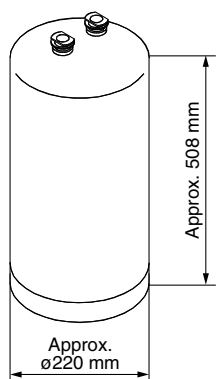

Weight: Approx. 20 kg

⑤ Insulating Material for DI Filter

When the DI filter is used at a high-temperature, we recommend that you use this insulating material to protect the radiated heat from the DI filter or possible burns. When the DI filter is used at a low-temperature, we also recommend that you use this to prevent heat absorption from the DI filter and to avoid forming condensation.

| Part no. | Applicable model |
|------------------|------------------|
| HRZ-DF002 | HRZF010-W1S-Y |

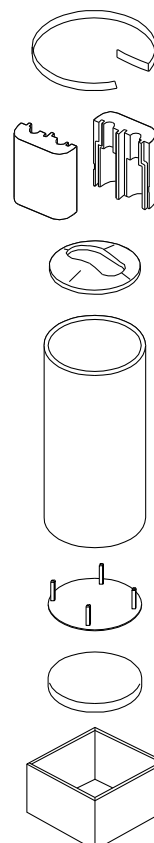

⑥ 60% Ethylene Glycol Aqueous Solution

This solution can be used as a circulating fluid for ethylene glycol-type thermo-chillers. (Capacity: 10 L)

| Part no. | Applicable model |
|------------------|------------------|
| HRZ-BR001 | HRZF010-W1S |

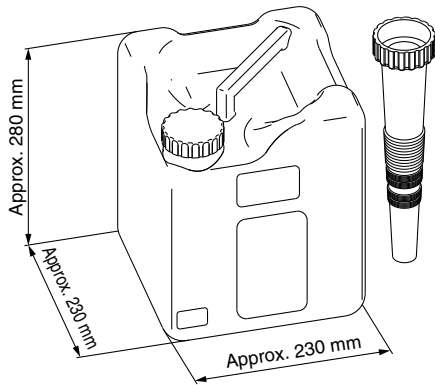

⑦ Concentration Meter

This meter can be used to control the condensation of ethylene glycol solution regularly.

| Part no. | Applicable model |
|------------------|------------------|
| HRZ-BR002 | HRZF010-W1S |

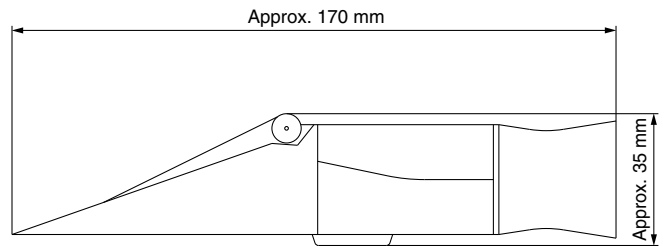



HRZF Series Specific Product Precautions 1

Be sure to read this before handling the products. Refer to the back cover for safety instructions. For temperature control equipment precautions, refer to the "Handling Precautions for SMC Products" and the "Operation Manual" on the SMC website: <https://www.smcworld.com>

Design

Warning

- This catalog shows the specifications of a single unit.**
 - For details, please refer to our "Product Specifications" and thoroughly consider the adaptability between the user's system and this unit.
 - Although a protection circuit as a single unit is installed, the user is requested to carry out a safety design for the whole system.
- This product uses a slightly flammable refrigerant (R454C). Avoid using this product in proximity to open flames. Ensure compliance with local laws and regulations regarding the use and application of this product.**



Facility Water Supply

Warning

<Water-cooled refrigeration>

- The water-cooled refrigeration type thermo-chiller radiates heat to the facility water. Prepare the facility water system that satisfies the facility water specifications below.**
- When using tap water as facility water, SMC recommends the water quality shown in the following table as reference.**

<Tap Water (as Facility Water) Quality Standards>

The Japan Refrigeration and Air Conditioning Industry Association
JRA GL-02-1994 "Cooling water system - Circulation type - Circulating water"

| | Item | Unit | Standard value | Influence | |
|----------------|--|---------|-------------------------|-----------|------------------|
| | | | | Corrosion | Scale generation |
| Standard item | pH (at 25°C) | — | 6.5 to 8.2 | ○ | ○ |
| | Electric conductivity (25°C) | [μS/cm] | 100*1 to 800*1 | ○ | ○ |
| | Chloride ion (Cl ⁻) | [mg/L] | 200 or less | ○ | |
| | Sulfuric acid ion (SO ₄ ²⁻) | [mg/L] | 200 or less | ○ | |
| | Acid consumption amount (at pH4.8) | [mg/L] | 100 or less | | ○ |
| | Total hardness | [mg/L] | 200 or less | | ○ |
| | Calcium hardness (CaCO ₃) | [mg/L] | 150 or less | | ○ |
| Reference item | Ionic state silica (SiO ₂) | [mg/L] | 50 or less | | ○ |
| | Iron (Fe) | [mg/L] | 1.0 or less | ○ | ○ |
| | Copper (Cu) | [mg/L] | 0.3 or less | ○ | |
| | Sulfide ion (S ₂ ⁻) | [mg/L] | Should not be detected. | ○ | |
| | Ammonium ion (NH ₄ ⁺) | [mg/L] | 1.0 or less | ○ | |
| | Residual chlorine (Cl) | [mg/L] | 0.3 or less | ○ | |
| | Free carbon (CO ₂) | [mg/L] | 4.0 or less | ○ | |

- *1 In the case of [MΩ·cm], it will be 0.001 to 0.01.
 ○: Factors that have an effect on corrosion or scale generation.
 • Even if the water quality standards are met, complete prevention of corrosion is not guaranteed.

- Set the supply pressure between 0.3 to 0.7 MPa. Ensure a pressure difference at the facility water inlet/outlet of 0.3 MPa or more.**

If the supply pressure is high, it will cause water leakage. If the supply pressure and pressure difference at the facility water inlet/outlet is low, it will cause an insufficient flow rate of the facility water, and poor temperature control.

Transportation / Carriage / Movement

Warning

- This product cannot be transported by air as this product uses a slightly flammable refrigerant (R454C).**
- Transporting with forklift**
 - It is not possible to hang this product.
 - The fork insertion position is either on the left side face or right side face of the unit. Be careful not to bump the fork against a caster or level foot and be sure to put through the fork to the opposite side.
 - Be careful not to bump the fork to the cover panel or piping ports.

3. Transporting with casters

- This product is heavy and should be moved by at least two people.
- Do not grip the pipings on the rear side or the handles of the panel.

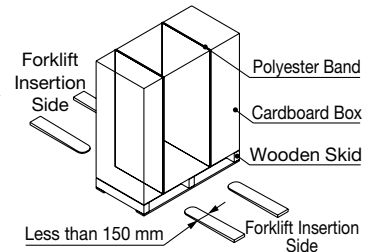

<When Packaged>

| Model | Weigh [kg] | Dimensions [mm] (Width x Depth x Height) |
|-------------|------------|--|
| HRZF010-W□S | 200 | 570 x 1200 x 1265 |

Mounting / Installation

Caution

- Avoid using this product outdoors.**
- Install on a rigid floor which can withstand this product's weight.**
- Install a suitable anchor bolt for the anti-quake bracket taking into consideration the user's floor material.**
- Avoid placing heavy objects on this product.**



HRZF Series

Specific Product Precautions 2

Be sure to read this before handling the products. Refer to the back cover for safety instructions. For temperature control equipment precautions, refer to the “Handling Precautions for SMC Products” and the “Operation Manual” on the SMC website: <https://www.smcworld.com>

Piping

Caution

- 1. The circulating fluid and facility water piping should be prepared by user with consideration of the operating pressure, temperature, and circulating fluid/facility compatibility.**

If the operating performance is not sufficient, the pipings may burst during operation. Also, the use of corrosive materials such as aluminum or iron for fluid contact parts, such as piping, may not only lead to clogging or leakage in the circulating fluid and facility water circuits but also refrigerant leakage and other unexpected problems. Provide protection against corrosion when you use the product.

- 2. The surface of the circulating fluid pipings should be covered with the insulating materials which can effectively confine the heat.**

Absorbing the heat from the surface of pipings may reduce the cooling capacity performance and the heating capacity may be shortened due to heat radiation.

- 3. When using fluorinated liquid as the circulating fluid, do not use pipe tape.**

Liquid leakage may occur around the pipe tape. For sealant, we recommend that you use the following sealant: SMC Part No., HRZ-S0003 (Silicone sealant)

- 4. For the circulating fluid pipings, use clean pipings which have no dust, oil or water moisture inside the pipings, and blow with air prior to undertaking any piping works.**

If any dust, oil or water moisture enters the circulating fluid circuit, inferior cooling performance or equipment failure due to frozen water may occur, resulting in bubbles in the circulating fluid inside the tank.

- 5. The reciprocating total volume of the circulating fluid pipings must be less than the volume of the sub-tank.**

Otherwise, when the equipment is stopped, the in-built alarm may activate or the circulating fluid may leak from the tank. Refer to the specifications table for the sub-tank volume.

- 6. Select the circulating fluid pipings which can exceed the required rated flow.**

For the rated flow, refer to the pump capacity table.

- 7. For the circulating fluid piping connection, install a drain pan just in case the circulating fluid may leak.**

- 8. Do not return the circulating fluid to the unit by installing a pump in the user’s system.**

- 9. The facility water flow rate is adjusted automatically according to the operating conditions. In addition, the facility water return temperature is 60°C at maximum.**

Refrigerant with GWP reference

| Refrigerant | Global Warming Potential (GWP) | | |
|-------------|--|--|---|
| | Regulation (EU) 2024/573, AIM Act 40 CFR Part 84 | Fluorocarbon Emissions Control Act (Japan) GWP value labeled on products | GWP value to be used for reporting the calculated amount of leakage |
| R134a | 1,430 | 1,430 | 1,300 |
| R404A | 3,922 | 3,920 | 3,940 |
| R407C | 1,774 | 1,770 | 1,620 |
| R410A | 2,088 | 2,090 | 1,920 |
| R448A | 1,386 | 1,390 | 1,270 |
| R454C | 146 | 145 | 146 |

*1 This product is hermetically sealed and contains fluorinated greenhouse gases.

*2 For refrigerant type used in this product, refer to the product specifications.

Temperature Control Equipment

These safety instructions are intended to prevent hazardous situations and/or equipment damage. These instructions indicate the level of potential hazard with the labels of “**Caution**,” “**Warning**” or “**Danger**.” They are all important notes for safety and must be followed in addition to International Standards (ISO/IEC), and other safety regulations.

Safety Instructions

 **Danger** : **Danger** indicates a hazard with a high level of risk which, if not avoided, will result in death or serious injury.

 **Warning** : **Warning** indicates a hazard with a medium level of risk which, if not avoided, could result in death or serious injury.

 **Caution** : **Caution** indicates a hazard with a low level of risk which, if not avoided, could result in minor or moderate injury.

Compliance Requirements

1. The use of SMC products with production equipment for the manufacture of weapons of mass destruction (WMD) or any other weapon is strictly prohibited.
2. The exports of SMC products or technology from one country to another are governed by the relevant security laws and regulations of the countries involved in the transaction. Prior to the shipment of a SMC product to another country, assure that all local rules governing that export are known and followed.

Limited warranty and Disclaimer/ Compliance Requirements

The product used is subject to the following “Limited warranty and Disclaimer” and “Compliance Requirements”.

Read and accept them before using the product.

Limited warranty and Disclaimer

1. Period

The warranty period of the product is 1 year in service or 1.5 years after the product is delivered, whichever is first.

2. Scope

For any failure reported within the warranty period which is clearly our responsibility, replacement parts will be provided. In that case, removed parts shall become the property of SMC.

This guarantee applies only to our product independently, and not to any other damage incurred due to the failure of the product.

3. Content

The following situations are out of scope of this warranty.

1. The product was incorrectly installed or connected with other equipment.
2. The product was modified or altered in construction.
3. The failure was a secondary failure of the product caused by the failure of equipment connected to the product.
4. The failure was caused by a natural disaster such as an earthquake, typhoon, or flood, or by an accident or fire.
5. The failure was caused by operation different from that shown in the Operation Manual or outside of the specifications.
6. The checks and maintenance specified (daily checks and regular checks) were not performed.
7. The failure was caused by the use of circulating fluid or facility water other than those specified.
8. The failure occurred naturally over time (such as discoloration of a painted or plated face).
9. The failure does not affect the functioning of the product (such as new sounds, noises and vibrations).
10. The failure was due to the “Installation Environment” specified in the Operation Manual.

4. Disclaimer

1. Expenses for daily and regular checks
2. Expenses for repairs performed by other companies
3. Expenses for transfer, installation and removal of the product
4. Expenses for replacement of parts other than those in this product, or for the supply of liquids
5. Inconvenience and loss due to product failure (such as telephone bills, compensation for workplace closure, and commercial losses)

For warranted repair, please contact the supplier you purchased this product from.

Warning

1. The compatibility of the product is the responsibility of the person who designs the equipment or decides its specifications.

Since the product specified here is used under various operating conditions, its compatibility with specific equipment must be decided by the person who designs the equipment or decides its specifications based on necessary analysis and test results. The expected performance and safety assurance of the equipment will be the responsibility of the person who has determined its compatibility with the product. This person should also continuously review all specifications of the product referring to its latest catalog information, with a view to giving due consideration to any possibility of equipment failure when configuring the equipment.

2. Only personnel with appropriate training should operate machinery and equipment.

The product specified here may become unsafe if handled incorrectly. The assembly, operation and maintenance of machines or equipment including our products must be performed by an operator who is appropriately trained and experienced.

3. Our products cannot be used beyond their specifications. Our products are not developed, designed, and manufactured to be used under the following conditions or environments. Use under such conditions or environments is not covered.

1. Conditions and environments outside of the given specifications, or use outdoors or in a place exposed to direct sunlight.
2. Use for nuclear power, railways, aviation, space equipment, ships, vehicles, military application, equipment affecting human life, body, and property, fuel equipment, entertainment equipment, emergency shut-off circuits, press clutches, brake circuits, safety equipment, etc., and use for applications that do not conform to standard specifications such as catalogs and operation manuals.
3. Use for interlock circuits, except for use with double interlock such as installing a mechanical protection function in case of failure. Please periodically inspect the product to confirm that the product is operating properly.

Caution

We develop, design, and manufacture our products to be used for automatic control equipment, and provide them for peaceful use in manufacturing industries.

Use in non-manufacturing industries is not covered.

Products we manufacture and sell cannot be used for the purpose of transactions or certification specified in the Measurement Act.

The new Measurement Act prohibits use of any unit other than SI units in Japan.

Safety Instructions

Be sure to read the “Handling Precautions for SMC Products” (M-E03-3) and “Operation Manual” before use.

SMC Corporation

Akihabara UDX 15F,
4-14-1, Sotokanda, Chiyoda-ku, Tokyo 101-0021, JAPAN
Phone: 03-5207-8249 Fax: 03-5298-5362
<https://www.smcworld.com>
© 2024 SMC Corporation All Rights Reserved

Specifications are subject to change without prior notice and any obligation on the part of the manufacturer.

D-G