

Circulating Fluid Temperature Controller

New

Low GWP Refrigerant Chiller



Thermo-chiller Rack Mount Type

Air-cooled Refrigeration Water-cooled Refrigeration

GWP:146^{*1}

EU refrigerant regulations: GWP150 or more
 US refrigerant regulations: GWP700 or more
 California, US refrigerant regulations: GWP750 or more

*1 Regulation (EU) 2024/573, AIM Act 40 CFR Part 84

Environmentally friendly **R454C** as refrigerant

Not available for air transport

Operable without the need to remove the unit from the rack

Front access

Simple to control, service, and maintain with all filters and drainage accessible via the front panel

Space saving

Multiple chillers can be mounted to a 19-inch rack.

*3 Refer below for details on 19-inch racks.

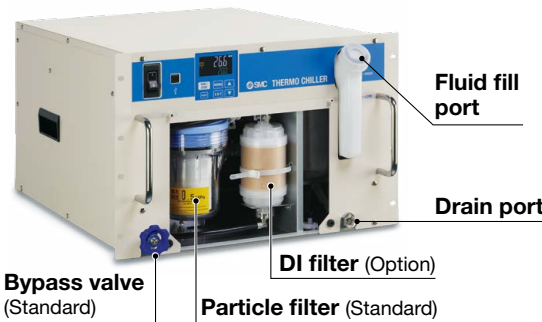

310 mm

Equivalent to 7U
 (EIA standards*3)



Cooling capacity **1.2/1.8 kW** (60 Hz)

Temperature stability **±0.1°C**

Power supply Single-phase **200 to 230 VAC** (50/60 Hz)

Space saving

Footprint can be reduced by **53%** by installing the product in a 19-inch rack (EIA standards*3).

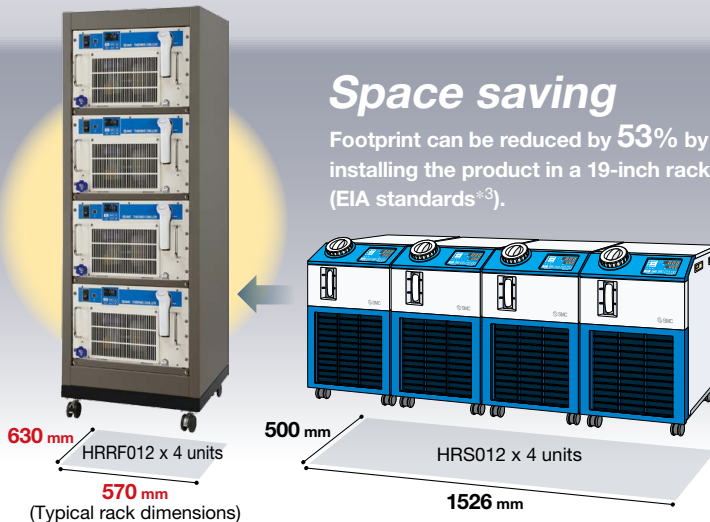

*3 19-inch Rack Standards

Standard	EIA (Electronic Industries Alliance)
Standard no.	EIA310-D
Height	44.5 mm (=1U)
Length	450 mm (min)
Width	483.4 mm

HRRF Series



CAT.ES40-78A

CONTENTS

HRRF Series



Circulating Fluid Temperature Controller

Low GWP Refrigerant Chiller

Thermo-chiller/Rack Mount Type HRRF Series

HRRF012/018

How to Order

Air-cooled Refrigeration (Single-phase 200 to 230 VAC)	p. 2
Water-cooled Refrigeration (Single-phase 200 to 230 VAC)	p. 2

Specifications

Air-cooled Refrigeration (Single-phase 200 to 230 VAC)	p. 3
Water-cooled Refrigeration (Single-phase 200 to 230 VAC)	p. 4
Cooling Capacity	p. 5
Heating Capacity	p. 5
Pump Capacity	p. 6
Required Facility Water Flow Rate	p. 6
Dimensions	
Air-cooled Refrigeration	p. 7
Water-cooled Refrigeration	p. 7

● Options

With Electric Conductivity Control Function, Applicable to DI Water Piping	p. 8
Applicable to DI Water Piping	p. 8
Inverter Pump Mounted	p. 9
High-Pressure Pump Mounted	p. 9
With Feet/Without Rack Mounting Brackets	p. 10
Removed Parts	p. 10

● Optional Accessories

① Concentration Meter	p. 11
② Particle Filter Element for Replacement	p. 11
③ DI Filter Replacement Cartridge	p. 11
④ Anti-quake Bracket	p. 11
⑤ Piping Conversion Fitting (For Air-cooled Refrigeration)	p. 12
⑥ Piping Conversion Fitting (For Water-cooled Refrigeration)	p. 12
⑦ Power Supply Cable	p. 12
⑧ Caster Adjuster-foot Kit	p. 13

● Cooling Capacity Calculation

Required Cooling Capacity Calculation	pp. 14, 15
Precautions on Cooling Capacity Calculation	p. 15
Circulating Fluid Typical Physical Property Values	p. 15

Specific Product Precautions	pp. 16, 17
------------------------------	------------

Low GWP Refrigerant Chiller

Thermo-chiller/Rack Mount Type Single-phase 200 to 230 VAC HRRF012/018



How to Order

Air-cooled refrigeration

HRRF **012** - **A** - **20** -

Cooling capacity

012	1000/1200 W (50/60 Hz)
018	1600/1800 W (50/60 Hz)

Cooling method

A	Air-cooled refrigeration
----------	--------------------------

Pipe thread type

Nil	Rc
F	G (With Rc-G conversion fitting set)
N	NPT (With Rc-NPT conversion fitting set)

Power supply

20	Single-phase 200 to 230 VAC (50/60 Hz)
-----------	--

Option (pp. 8 to 10)

Nil	None
DM	With electric conductivity control function, Applicable to DI water piping
M	Applicable to DI water piping
T ^{*1}	High-pressure pump mounted
T1 ^{*1}	Inverter pump mounted
Y	With feet/Without rack mounting brackets
Z ^{*2}	Without either a flow sensor, water leakage sensor, particle filter, bypass valve or retaining clip
Z1 ^{*2}	Without either a flow sensor or retaining clip

*1 Only Option T or T1 can be selected.

*2 Only Option Z or Z1 can be selected.

· When multiple options are combined, indicate symbols in alphabetical order.

Water-cooled refrigeration

HRRF **012** - **W** - **20** -

Cooling capacity

012	1000/1200 W (50/60 Hz)
018	1600/1800 W (50/60 Hz)

Cooling method

W	Water-cooled refrigeration
----------	----------------------------

Pipe thread type

Nil	Rc
F	G (With Rc-G conversion fitting set)
N	NPT (With Rc-NPT conversion fitting set)

Power supply

20	Single-phase 200 to 230 VAC (50/60 Hz)
-----------	--

Option (pp. 8 to 10)

Nil	None
DM	With electric conductivity control function, Applicable to DI water piping
M	Applicable to DI water piping
T ^{*1}	High-pressure pump mounted
T1 ^{*1}	Inverter pump mounted
Y	With feet/Without rack mounting brackets
Z ^{*2}	Without either a flow sensor, water leakage sensor, particle filter, bypass valve or retaining clip
Z1 ^{*2}	Without either a flow sensor or retaining clip

*1 Only Option T or T1 can be selected.

*2 Only Option Z or Z1 can be selected.

· When multiple options are combined, indicate symbols in alphabetical order.

Specifications: 200 to 230 VAC Air-cooled Refrigeration

Model	HRRF012-A-20	HRRF018-A-20
Cooling method	Air-cooled refrigeration	
Refrigerant	R454C (HFO/HFC, GWP: 146) ^{*21}	
Refrigerant charge [kg]	0.30	
Control method	PID control	
Ambient temperature/Humidity/Altitude ^{*1, 13}	Temperature: 5 to 40°C, Humidity: 30 to 70%, Altitude: less than 3000 m	
Circulating fluid ^{*2}	Tap water, 15% ethylene glycol aqueous solution	
Set temperature range ^{*1} [°C]	5 to 35	
Cooling capacity (50/60 Hz) ^{*3} [W]	1000/1200	1600/1800
Heating capacity (50/60 Hz) ^{*4} [W]	450/500	
Temperature stability ^{*5} [°C]	±0.1	
Pump capacity (50/60 Hz) ^{*6} [MPa]	0.13 (at 7 L/min)/0.18 (at 7 L/min) For Option T: 0.42 (at 10 L/min)/0.4 (at 14 L/min) For Option MT: 0.32 (at 10 L/min)/0.32 (at 14 L/min) For Option T1: 0.28 (at 10 L/min)/0.28 (at 10 L/min)	
Rated flow (50/60 Hz) ^{*7} [L/min]	7/7 For Options T, MT: 10/14, For Option T1: 10/10	
Flow display range ^{*20} [L/min]	2 to 16	
Electric conductivity display range [µS/cm]	0.1 to 48 (Only for Option DM)	
Electric conductivity setting range [µS/cm]	0.5 to 45 (Only for Option DM)	
Particle filter nominal filtration rating ^{*19} [µm]	5	
Bypass valve ^{*19}	Installed	
Tank capacity [L]	Approx. 4	
Outlet, Return port size	Rc1/2	
Drain port size	Rc1/4, With cap	
Leakage protection	Drain pan (With water leakage sensor ^{*19})	
Fluid contact material	Stainless steel, Copper (Heat exchanger brazing) ^{*11} , Brass ^{*16} , SiC, Alumina ceramic, Carbon, PP, PE, POM, PA, FKM, EPDM, PVC, PPS, AS, Fluoropolymer ^{*12} , Ion exchange resin ^{*12}	
Power supply	Single-phase 200 to 230 VAC, 50/60 Hz, Allowable voltage range ±10% ^{*14}	
Circuit protector [A]	10 For Options T, MT, T1: 15	
Applicable earth leakage breaker capacity ^{*8}	Rated current: 10 A For Options T, MT, T1: 15 A Sensitivity current: 30 mA	
Cable quantity x Size (Including grounding cable) ^{*15}	3 cores x 14 AWG (3 cores x 2.0 mm ²)	
Rated operating current (50/60 Hz) ^{*17} [A]	4.9/5.9	5.1/6.2
	For Options T, MT	
	6.1/7.8	6.6/8.4
	For Option T1	
Rated power consumption (50/60 Hz) ^{*17} [kW (kVA)]	5.9/6.7	6.2/7.1
	For Options T, MT	
	0.8/1.1 (1.0/1.2)	0.9/1.2 (1.0/1.3)
	For Option T1	
Communication function	Contact input/output, Serial RS-485/RS-232C	
	Noise level (50/60 Hz) ^{*9} [dB]	59/60
	Accessories ^{*18}	Power supply connector, Particle filter element and maintenance handle ^{*19} , Operation manual
Weight ^{*10} [kg]	45	

*1 No condensation should be present. Use 15% ethylene glycol aqueous solution when operating at a temperature of 10°C or less.

*2 If tap water is used, use water that is compliant with the Water Quality Standards of the Japan Refrigeration and Air Conditioning Industry Association (JRA GL-02-1994 cooling water system - circulating type - make-up water).

*3 ① Ambient temperature: 25°C, ② Circulating fluid temperature: 20°C, ③ Circulating fluid at the rated flow, ④ Circulating fluid: Tap water, ⑤ Power supply: 200 VAC, ⑥ Piping length: Shortest
For Options "T," "MT" (high-pressure pump mounted type), and "T1" (inverter pump mounted type), the cooling capacity will decrease by approx. 300 W.

*4 ① Ambient temperature: 25°C, ② Circulating fluid temperature: 20°C, ③ Circulating fluid at the rated flow, ④ Circulating fluid: Tap water, ⑤ Power supply: 200 VAC, ⑥ Piping length: Shortest

*5 Temperature at the thermo-chiller outlet when the circulating fluid flow is at the rated flow and the circulating fluid outlet and return port are directly connected
The installation environment and power supply are within the specification range and stable.

*6 The capacity at the thermo-chiller outlet when the circulating fluid temperature is 20°C

*7 The required flow rate for maintaining the cooling capacity or temperature stability
The specification of the cooling capacity and the temperature stability may not be satisfied if the flow rate is lower than the rated flow.

*8 Purchase an earth leakage breaker with a sensitivity current of 30 mA and a power supply of 200 VAC separately.

*9 Front: 1 m, height: 1 m, stable with no load, Other conditions → See *4.

*10 Weight in the dry state without circulating fluids

The weight will increase by 1 kg when Option DM (With electric conductivity control function, Applicable to DI water piping) is selected.

The weight will increase by 5 kg when Options T (High-pressure pump mounted) or MT (Applicable to DI water piping + High-pressure pump mounted) are selected.

The weight will increase by 1 kg when Options T1 (Inverter pump mounted) or Z (Removed parts) are selected.

*11 Options M (Applicable to DI water piping) and MT (Applicable to DI water piping + High-pressure pump mounted) do not contain copper or brass.

*12 For Option DM (With electric conductivity control function, Applicable to DI water piping)

*13 If the product is used at an altitude of 1000 meters or higher, the maximum allowable ambient temperature and the cooling capacity decrease. For details, refer to the operation manual.

*14 No continuous voltage fluctuation

*15 To be prepared by the customer

*16 Option T (High-pressure pump mounted) contains this material.

*17 ① Ambient temperature: 25°C, ② Circulating fluid temperature: 20°C,

③ Circulating fluid at the rated flow, ④ Circulating fluid: Tap water, ⑤ Power supply: 200 VAC, ⑥ Piping length: Shortest, ⑦ With the rated cooling load applied

*18 For Option DM (With electric conductivity control function, Applicable to DI water piping), a DI filter is included.

For pipe thread type F, a G thread conversion fitting set is included.

For pipe thread type N, an NPT thread conversion fitting set is included.

*19 Not included for Option Z (Removed parts)

*20 Not included for Options Z and Z1 (Removed parts)

*21 R454C is a slightly flammable refrigerant. Avoid using this product in proximity to open flames.

Specifications: 200 to 230 VAC Water-cooled Refrigeration

Model	HRRF012-W-20	HRRF018-W-20
Cooling method	Water-cooled refrigeration	
Refrigerant	R454C (HFO/HFC, GWP: 146) ^{*22}	
Refrigerant charge [kg]	0.22	
Control method	PID control	
Ambient temperature/Humidity/Altitude ^{*1, 14}	Temperature: 5 to 40°C, Humidity: 30 to 70%, Altitude: less than 3000 m	
Circulating fluid ^{*2}	Tap water, 15% ethylene glycol aqueous solution	
Set temperature range ^{*1} [°C]	5 to 35	
Cooling capacity (50/60 Hz) ^{*3} [W]	1000/1200	1600/1800
Heating capacity (50/60 Hz) ^{*4} [W]	450/500	
Temperature stability ^{*5} [°C]	±0.1	
Pump capacity (50/60 Hz) ^{*6} [MPa]	0.13 (at 7 L/min)/0.18 (at 7 L/min) For Option T: 0.42 (at 10 L/min)/0.4 (at 14 L/min) For Option MT: 0.32 (at 10 L/min)/0.32 (at 14 L/min) For Option T1: 0.28 (at 10 L/min)/0.28 (at 10 L/min)	
Rated flow (50/60 Hz) ^{*7} [L/min]	7/7 For Options T, MT: 10/14, For Option T1: 10/10	
Flow display range ^{*21} [L/min]	2 to 16	
Electric conductivity display range [µS/cm]	0.1 to 48 (Only for Option DM)	
Electric conductivity setting range [µS/cm]	0.5 to 45 (Only for Option DM)	
Particle filter nominal filtration rating ^{*20} [µm]	5	
Bypass valve ^{*20}	Installed	
Tank capacity [L]	Approx. 4	
Outlet, Return port size	Rc1/2	
Drain port size	Rc1/4, With cap	
Leakage protection	Drain pan (With water leakage sensor ^{*20})	
Fluid contact material	Stainless steel, Copper (Heat exchanger brazing) ^{*11} , Brass ^{*17} , SiC, Alumina ceramic, Carbon, PP, PE, POM, PA, FKM, EPDM, PVC, PPS, AS, Fluoropolymer ^{*12} , Ion exchange resin ^{*12}	
Temperature range [°C]	5 to 40	
Pressure range [MPa]	0.3 to 0.5	
Required flow rate (50/60 Hz) ^{*13} [L/min]	8	12
Inlet-outlet pressure differential of facility water [MPa]	0.3 or more	
Port size	Rc3/8	
Fluid contact material	Stainless steel, Copper (Heat exchanger brazing), Bronze, Brass, NBR, EPDM	
Power supply	Single-phase 200 to 230 VAC, 50/60 Hz, Allowable voltage range ±10% ^{*15}	
Circuit protector [A]	10 For Options T, MT, T1: 15	
Applicable earth leakage breaker capacity ^{*8}	Rated current: 10 A For Options T, MT, T1: 15 A Sensitivity current: 30 mA	
Cable quantity x Size (Including grounding cable) ^{*16}	3 cores x 14 AWG (3 cores x 2.0 mm ²)	
Rated operating current (50/60 Hz) ^{*18} [A]	4.5/5.1	4.7/5.3
	For Options T, MT	
	5.4/6.8	5.7/7.2
Rated power consumption (50/60 Hz) ^{*18} [kW (kVA)]	For Option T1	
	5.6/6.2	5.8/6.4
	0.8/1.0 (0.9/1.0)	0.8/1.0 (0.9/1.0)
Rated power consumption (50/60 Hz) ^{*18} [kW (kVA)]	For Options T, MT	
	1.1/1.4 (1.1/1.4)	1.1/1.5 (1.2/1.5)
	For Option T1	
	1.0/1.1 (1.2/1.4)	1.0/1.2 (1.2/1.5)
Communication function	Contact input/output, Serial RS-485/RS-232C	
Noise level (50/60 Hz) ^{*9} [dB]	59/60	59/60
Accessories ^{*19}	Power supply connector, Particle filter element and maintenance handle ^{*20} , Operation manual	
Weight ^{*10} [kg]	45	

*1 No condensation should be present. Use 15% ethylene glycol aqueous solution when operating at a temperature of 10°C or less.
 *2 If tap water is used, use water that is compliant with the Water Quality Standards of the Japan Refrigeration and Air Conditioning Industry Association (JRA GL-02-1994 cooling water system - circulating type - make-up water).
 *3 ① Facility water temperature: 25°C, ② Circulating fluid temperature: 20°C, ③ Circulating fluid at the rated flow, ④ Circulating fluid: Tap water, ⑤ Power supply: 200 VAC, ⑥ Piping length: Shortest
 For Options "T," "MT" (high-pressure pump mounted type), and "T1" (inverter pump mounted type), the cooling capacity will decrease by approx. 300 W.
 *4 ① Ambient temperature: 25°C, ② Facility water temperature: 25°C, ③ Circulating fluid temperature: 20°C, ④ Circulating fluid at the rated flow, ⑤ Circulating fluid: Tap water, ⑥ Power supply: 200 VAC, ⑦ Piping length: Shortest
 *5 Temperature at the thermo-chiller outlet when the circulating fluid flow is at the rated flow and the circulating fluid outlet and return port are directly connected
 The installation environment and power supply are within the specification range and stable.
 *6 The capacity at the thermo-chiller outlet when the circulating fluid temperature is 20°C
 *7 The required flow rate for maintaining the cooling capacity or temperature stability
 The specification of the cooling capacity and the temperature stability may not be satisfied if the flow rate is lower than the rated flow.
 *8 Purchase an earth leakage breaker with a sensitivity current of 30 mA and a power supply of 200 VAC separately.
 *9 Front: 1 m, height: 1 m, stable with no load, Other conditions → See *4.

*10 Weight in the dry state without circulating fluids and facility water (for water-cooled refrigeration)
 The weight will increase by 1 kg when Option DM (With electric conductivity control function, Applicable to DI water piping) is selected.
 The weight will increase by 5 kg when Options T (High-pressure pump mounted) or MT (Applicable to DI water piping + High-pressure pump mounted) are selected.
 The weight will increase by 1 kg when Options T1 (Inverter pump mounted) or Z (Removed parts) are selected.
 *11 Options M (Applicable to DI water piping) and MT (Applicable to DI water piping + High-pressure pump mounted) do not contain copper or brass.
 *12 For Option DM (With electric conductivity control function, Applicable to DI water piping)
 *13 The required flow rate when the cooling capacity load is applied under the conditions in *3. The actual flow rate of facility water will fluctuate according to your operating conditions.
 *14 If the product is used at an altitude of 1000 meters or higher, the maximum allowable ambient temperature and the cooling capacity decrease. For details, refer to the operation manual.
 *15 No continuous voltage fluctuation
 *16 To be prepared by the customer
 *17 Option T (High-pressure pump mounted) contains this material.
 *18 ① Facility water temperature: 25°C, ② Circulating fluid temperature: 20°C, ③ Circulating fluid at the rated flow, ④ Circulating fluid: Tap water, ⑤ Power supply: 200 VAC, ⑥ Piping length: Shortest, ⑦ With the rated cooling load applied
 *19 For Option DM (With electric conductivity control function, Applicable to DI water piping), a DI filter is included.
 For pipe thread type F, a G thread conversion fitting set is included.
 For pipe thread type N, an NPT thread conversion fitting set is included.
 *20 Not included for Option Z (Removed parts)
 *21 Not included for Options Z and Z1 (Removed parts)
 *22 R454C is a slightly flammable refrigerant. Avoid using this product in proximity to open flames.

HRRF Series

Cooling Capacity

* If the product is used at an altitude of 1000 meters or higher, the maximum allowable ambient temperature and the cooling capacity decrease. For details, refer to the operation manual.
 * For models with a high-pressure pump mounted (-T, -MT), the cooling capacity will decrease by about 300 W from each graph.

HRRF012-A-20, HRRF012-W-20 [50 Hz]

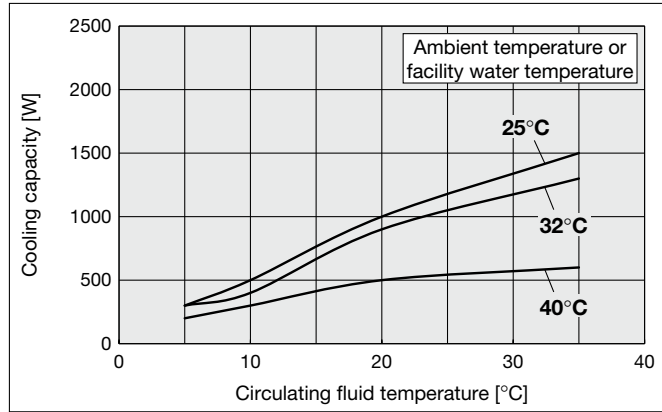

[60 Hz]

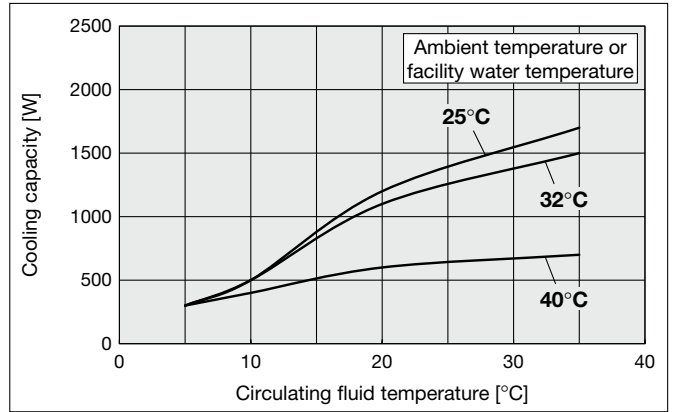

HRRF018-A-20, HRRF018-W-20 [50 Hz]

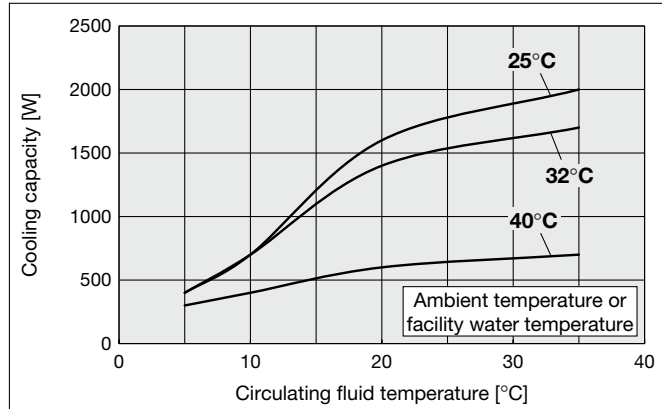

[60 Hz]

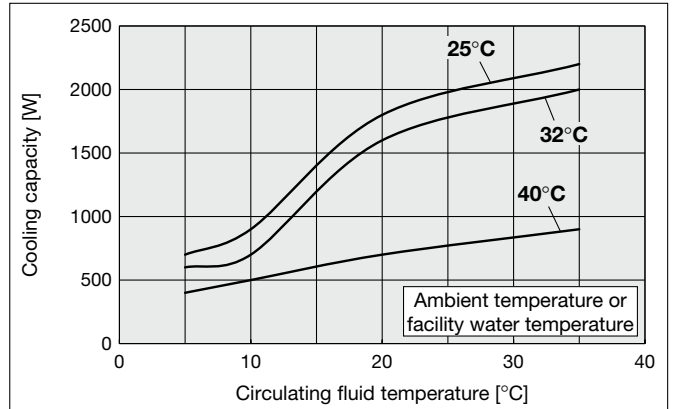

Heating Capacity

HRRF⁰¹²₀₁₈-A-20, HRRF⁰¹²₀₁₈-W-20 [50 Hz]

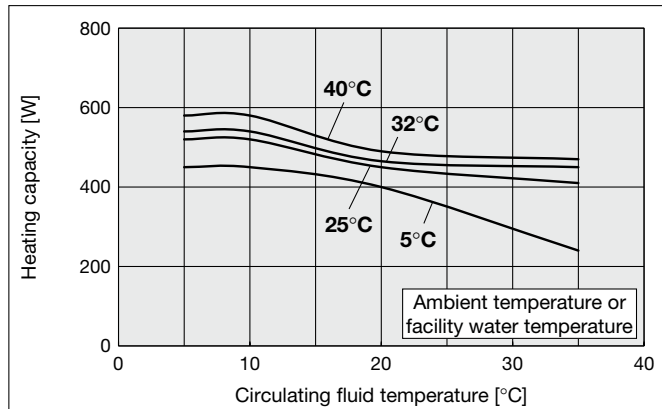

[60 Hz]

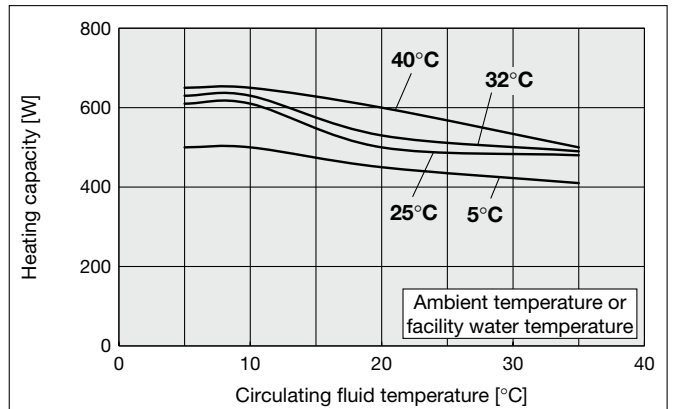

Pump Capacity

HRRF⁰¹²₀₁₈-A-20, HRRF⁰¹²₀₁₈-W-20

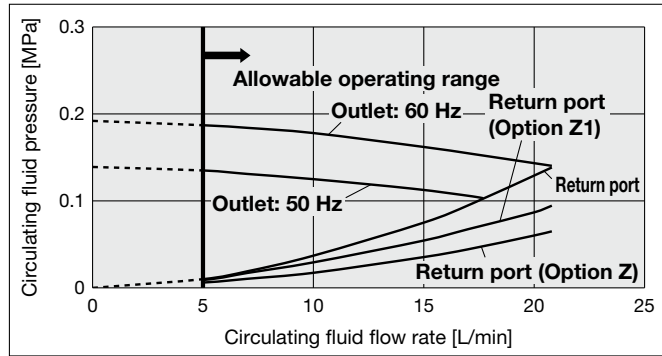

* The flow rate is displayed up to 16 L/min on the chiller display.

Required Facility Water Flow Rate

HRRF⁰¹²₀₁₈-W

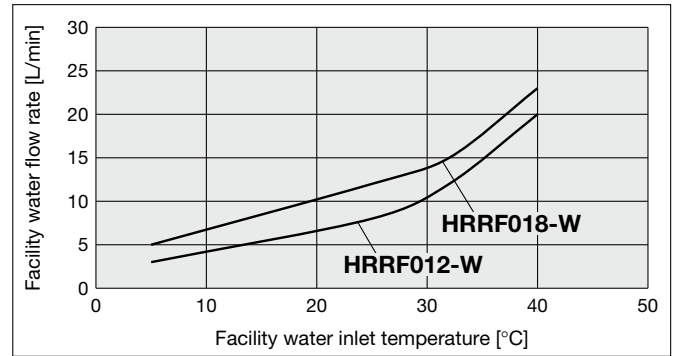

* This is the required facility water flow rate at the circulating fluid rated flow and the cooling capacity listed in the "Cooling Capacity" specifications.

HRRF Series

Dimensions

Air-cooled refrigeration

HRRF012-A, HRRF018-A

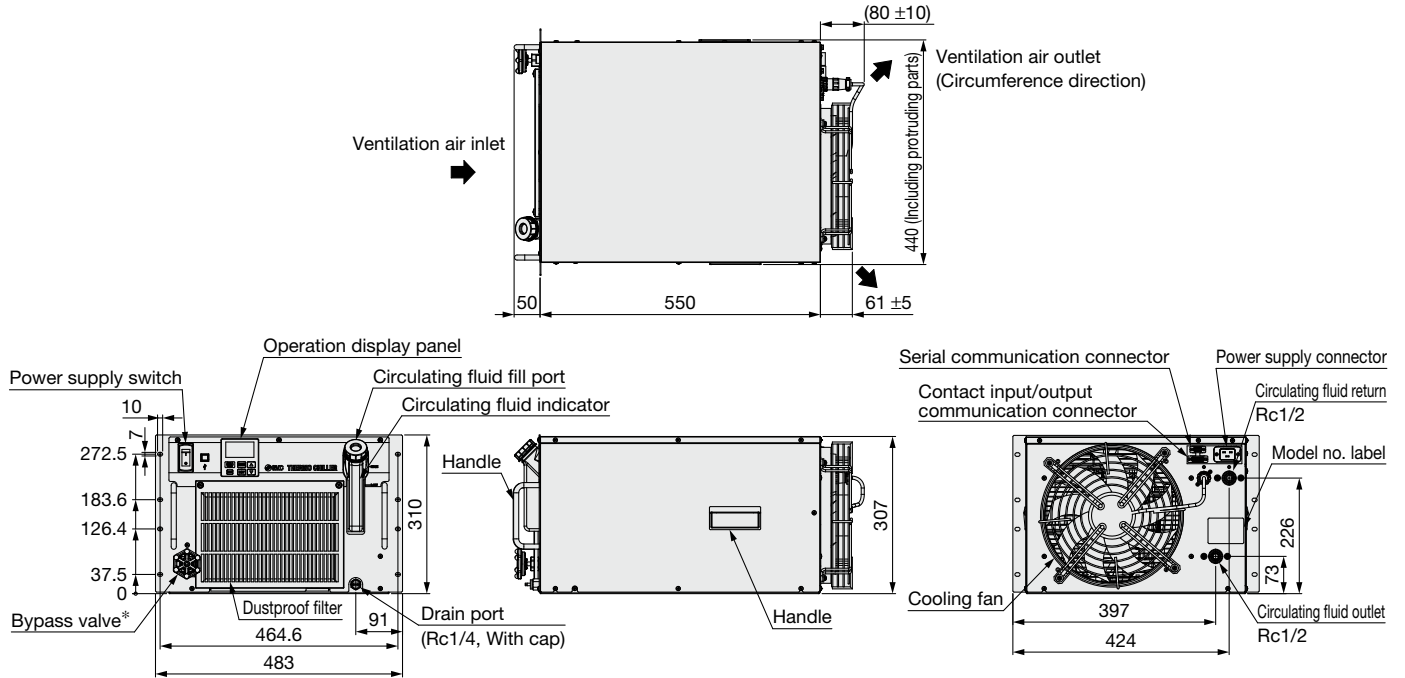

* In the case of Option Z, without the bypass valve.

Water-cooled refrigeration

HRRF012-W, HRRF018-W

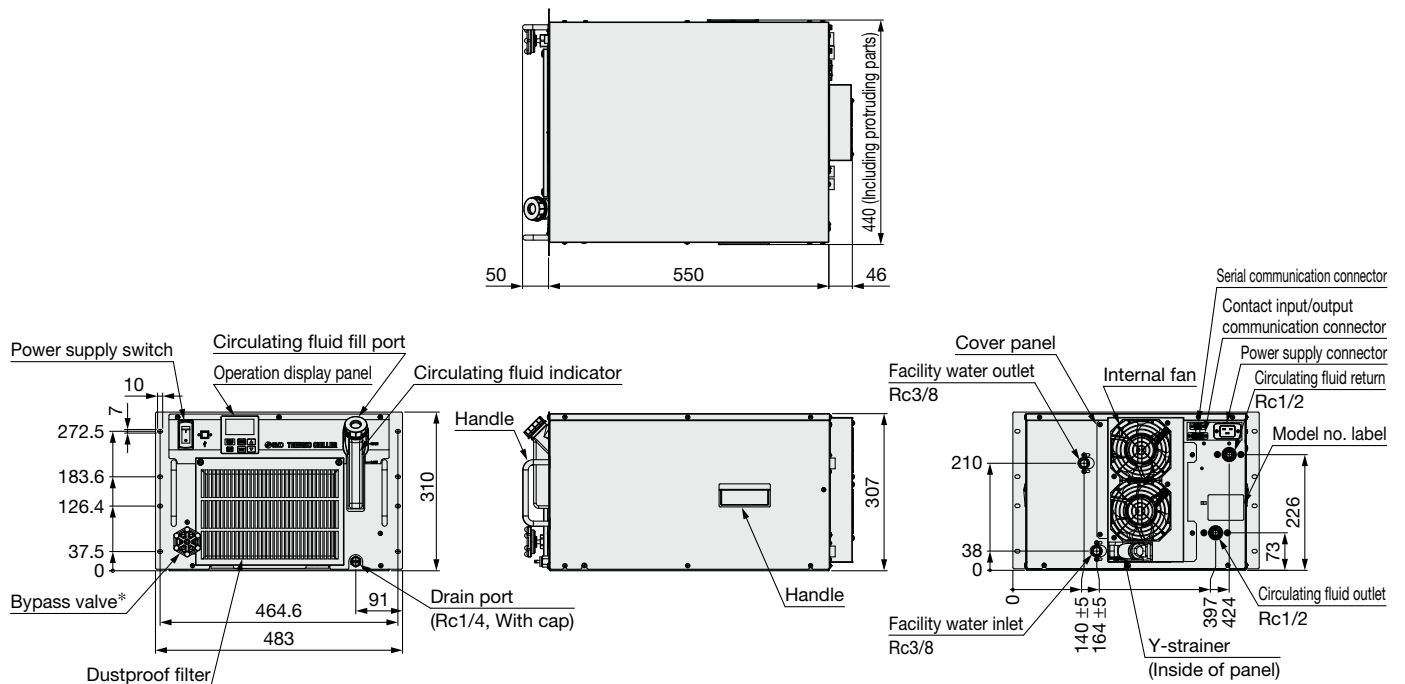

* In the case of Option Z, without the bypass valve.

* For the dimensions of Option Y, refer to the following drawing.
HRRF012-W□-20-□Y□

* Only Option Z or Z1 can be selected.

* Only Option T or T1 can be selected.

HRRF Series Options

* Options have to be selected when ordering the thermo-chiller. It is not possible to add them after purchasing the unit.

DM Option symbol

With Electric Conductivity Control Function, Applicable to DI Water Piping

HRRF - - 20 - DM

• With electric conductivity control function, Applicable to DI water piping

By entering the set value of electric conductivity and hysteresis, flow of circulating fluid to the DI filter is controlled by the solenoid valve to control electric conductivity. Contact material of the circulating fluid circuit is made from non-copper materials. (For details, refer to Option M.)

Applicable model	HRRF012/018- <input type="text"/> -20-DM
Measurement range of electric conductivity	0.1 to 48.0 $\mu\text{S/cm}$
Set range of target electric conductivity	0.5 to 45.0 $\mu\text{S/cm}^{*1}$
Set range of electric conductivity hysteresis	0.1 to 10.0 $\mu\text{S/cm}$

*1 Default setting is set to "Electric conductivity set value: 25.0 $\mu\text{S/cm}$ " and "Hysteresis: 5.0 $\mu\text{S/cm}$."

Example of operation of electric conductivity control

- Electric conductivity target value : 25.0 [$\mu\text{S/cm}$]
- Electric conductivity control hysteresis: 5.0 [$\mu\text{S/cm}$]

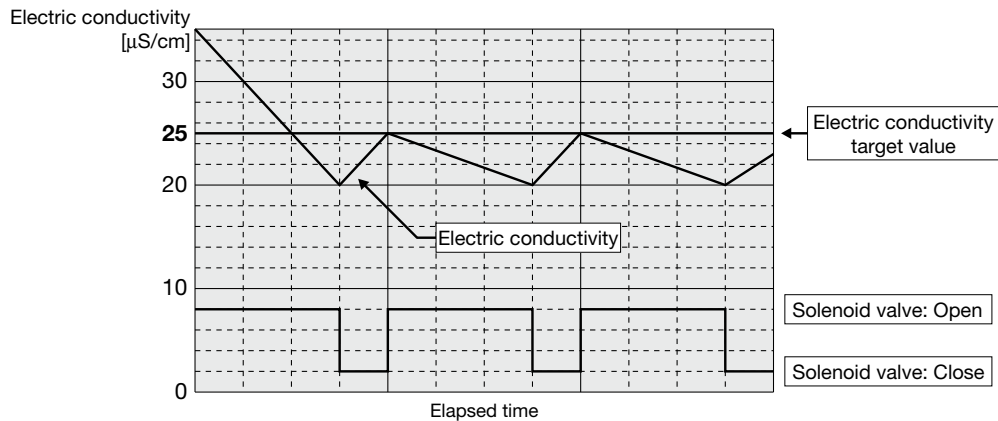

M Option symbol

Applicable to DI Water Piping

HRRF - - 20 - M

• Applicable to DI water piping

Contact material of the circulating fluid circuit is made from non-copper materials.

- Available DI water is electric conductivity: 0.4 $\mu\text{S/cm}$ or more. (Electric resistivity: 2.5 $\text{M}\Omega\text{-cm}$ or less)
- This Option M does not have electric resistance/electric conductivity control function. If this function is necessary, Option DM should be selected.

Applicable model	HRRF012/018- <input type="text"/> -20-M
Contact material for circulating fluid	Stainless steel (including heat exchanger brazing), Alumina ceramic, SiC, Carbon, PP, PE, POM, PA, FKM, EPDM, PVC, PPS, AS

* No change in external dimensions

HRRF Series

T1 Option symbol Inverter Pump Mounted

HRRF --20-T1

● Inverter pump mounted

Possible to choose an inverter pump in accordance with user's piping resistance
Cooling capacity will decrease by heat generated in the pump.

- The inverter pump does not use a mechanical seal.
- The 50 Hz and the 60 Hz inverter pumps have the same capacity.
(There is no pump capacity difference between the 50 Hz and the 60 Hz.)

Applicable model		HRRF012/018- <input type="text"/> -20-T1	
Pump	Rated flow (50/60 Hz)*1, *2	L/min	10 (0.28 MPa)
	Max. pump head (50/60 Hz)	m	40
	Output	W	400
Circuit protector		A	15
Recommended earth leakage breaker capacity		A	15
Cooling capacity		W	The cooling capacity reduces about 300 W from the value in the catalog. Due to an increase in the heat generation of the pump.

- *1 The capacity at the thermo-chiller outlet when the circulating fluid temperature is 20°C.
- *2 Required minimum flow rate for maintaining the cooling capacity or temperature stability.
- * The product weight will decrease by 1 kg.
- * No change in external dimensions of this product.

Pump Capacity

HRRF012/018--20-T1

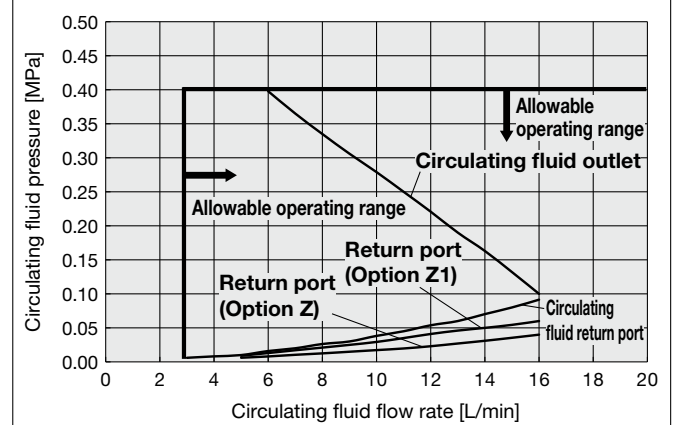

- * For Options "-Z" and "-Z1," operate within the range in which AL17 (flow rate failure) is not generated.
- * The flow rate is displayed up to 16 L/min on the chiller display.

T Option symbol High-Pressure Pump Mounted

HRRF --20-T/MT

● High-pressure pump mounted

Possible to choose a high-pressure pump in accordance with user's piping resistance
Cooling capacity will decrease by heat generated in the pump.

- The high-pressure pump uses a mechanical seal.
- The thermo-chiller indicates maintenance notification when driving time is passed a recommended preventive maintenance hours.
Please contact to service center to ask for maintenance of the pump and mechanical seal.

Applicable model		HRRF012/018- <input type="text"/> -20-T		HRRF012/018- <input type="text"/> -20-MT*1	
Pump	Rated flow (50/60 Hz)*2, 3	L/min	10 (0.42 MPa)/14 (0.40 MPa)	10 (0.32 MPa)/14 (0.32 MPa)	
	Max. pump head (50/60 Hz)	m		50	
	Output	W		550	
Circuit protector		A		15	
Recommended earth leakage breaker capacity		A		15	
Cooling capacity*4		W	The cooling capacity reduces about 300 W from the value in the catalog. Due to an increase in the heat generation of the pump.		

- *1 Option MT: Applicable to DI water piping + High-pressure pump mounted
- *2 The capacity at the thermo-chiller outlet when the circulating fluid temperature is 20°C.
- *3 Required minimum flow rate for maintaining the cooling capacity or temperature stability.
- *4 Cooling capacity will decrease as pump power increases.
- * When the option, high-pressure pump mounted, is selected, the product weight increases by 5 kg.
- * No change in external dimensions of this product.

Pump Capacity

HRRF012/018--20-T

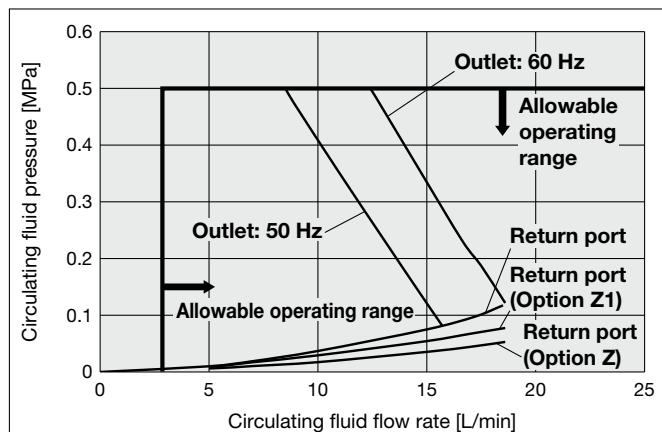

- * The flow rate is displayed up to 16 L/min on the chiller display.

HRRF012/018--20-MT

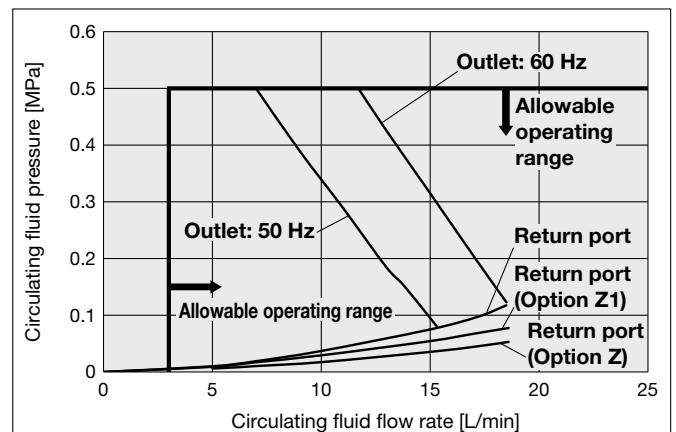

- * The flow rate is displayed up to 16 L/min on the chiller display.

* Options have to be selected when ordering the thermo-chiller.
It is not possible to add them after purchasing the unit.

Y Option symbol
With Feet/Without Rack Mounting Brackets

Air-cooled refrigeration

Water-cooled refrigeration

HRRF [] - [] [] - 20 - Y

● With feet/Without rack mounting brackets

Instead of the 19-inch rack mounting brackets, the product comes with rubber legs under its base.

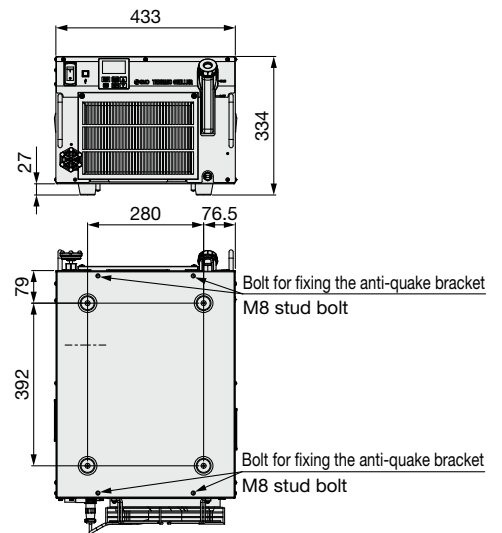

Z Option symbol
Removed Parts

Air-cooled refrigeration

Water-cooled refrigeration

HRRF [] - [] [] - 20 - Z/Z1

● Removed parts

Standard product without the parts below

Z	Flow sensor, Water leakage sensor, Particle filter, Bypass valve, Retaining clip
Z1	Flow sensor, Retaining clip

HRRF Series

Optional Accessories

① Concentration Meter

This meter can be used to control the concentration of ethylene glycol aqueous solution regularly.

Part number	Applicable model
HRZ-BR002	HRRF012/018

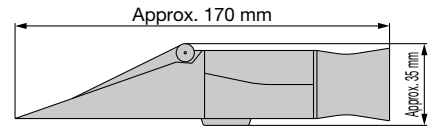

② Particle Filter Element for Replacement

Element for the maintenance of the particle filter for circulating fluid

Part number	Applicable model
EJ202S-005X11	HRRF012/018

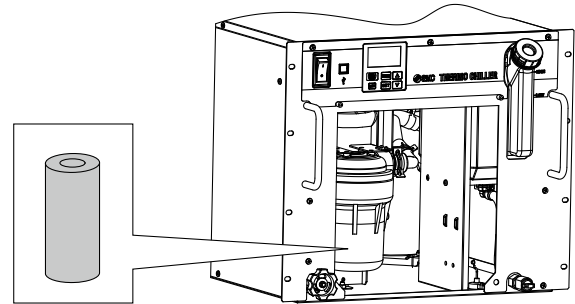

③ DI Filter Replacement Cartridge

DI filter cartridge for replacement for Option DM [Electric conductivity control type, DI water piping type]

Part number	Applicable model
HRR-DF001	HRRF012/018-□□-20-DM□

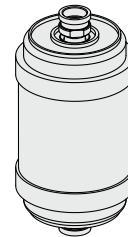

④ Anti-quake Bracket

Bracket for earthquakes

Prepare the anchor bolts (M8) which are suited to the floor material by the customer. (Anti-quake bracket material: Stainless steel, thickness: 1.5 mm)

Part number	Applicable model
HRR-TK001	HRRF012/018-□□-20-□Y□

Parts List

Description	Qty.
Anti-quake bracket A	2
Anti-quake bracket B	2
Nut (M8)	4
Bolt (M8)	4

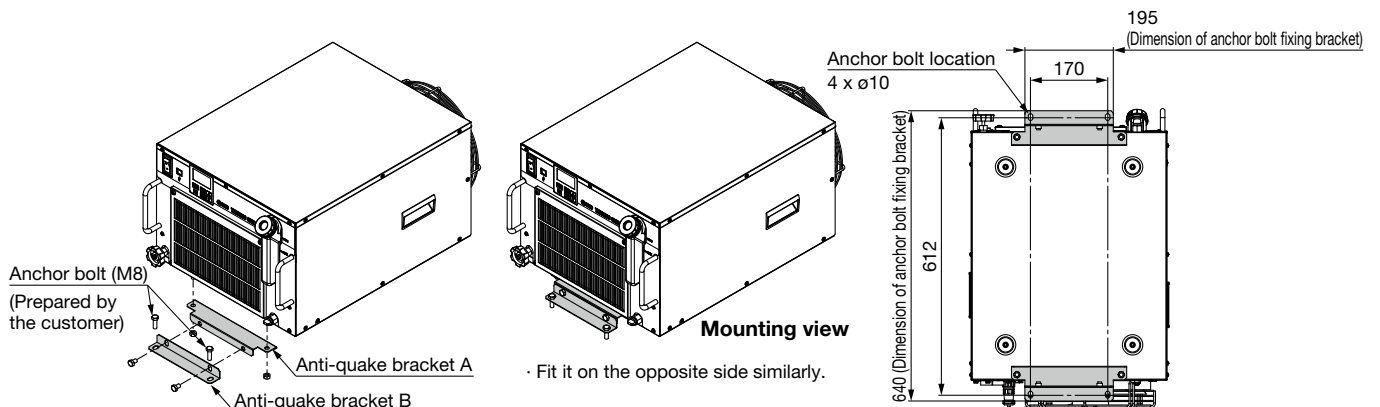

⑤ Piping Conversion Fitting (For Air-cooled Refrigeration)

■ Conversion fitting for circulating fluid + Conversion fitting for drain outlet

This fitting changes the port size for circulating fluid from Rc1/2 to G1/2 or NPT1/2, and for drain from Rc1/4 to G1/4 or NPT1/4. It is not necessary to purchase this when pipe thread type F or N is selected in "How to Order" since it is included in the product.

Part number	Applicable model
HRR-EP001	G thread conversion fitting set
HRR-EP002	NPT thread conversion fitting set

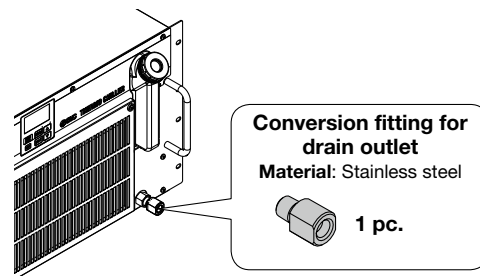
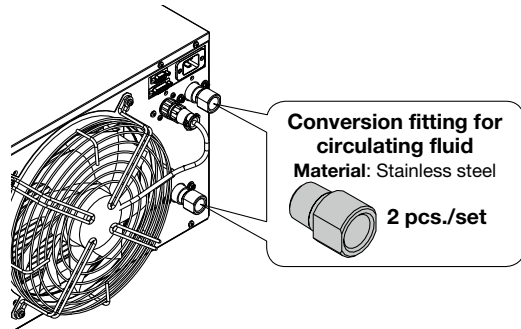

⑥ Piping Conversion Fitting (For Water-cooled Refrigeration)

■ Conversion fitting for circulating fluid + Conversion fitting for drain outlet

This fitting changes the port size for circulating fluid from Rc1/2 to G1/2 or NPT1/2, and for drain from Rc1/4 to G1/4 or NPT1/4. It is not necessary to purchase this when pipe thread type F or N is selected in "How to Order" since it is included in the product.

Part number	Applicable model
HRR-EP003	G thread conversion fitting set
HRR-EP004	NPT thread conversion fitting set

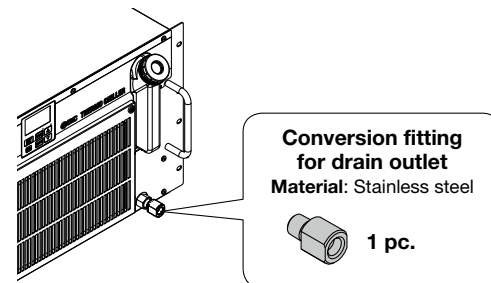
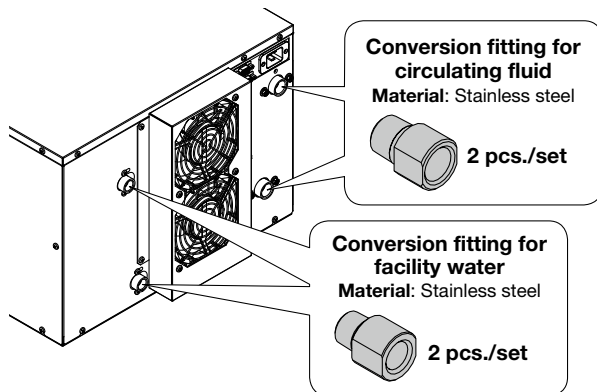

⑦ Power Supply Cable

Part number	Applicable model
HRR-CA001	HRRF012/018-□□-20

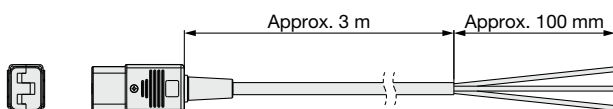

HRRF Series

⑧ Caster Adjuster-foot Kit

This is a set of unfixed casters and adjuster feet stop.

This kit can only be used for Option Y of the thermo-chiller HRR□ series.

Do not mount this kit on other products.

Carefully read the procedure manual included with this kit before performing the installation.

Part number	Applicable model	A dimension [mm]	Weight [kg]
HRR-KS001	HRRF012/018-□□-20-□Y	417	Approx. 7

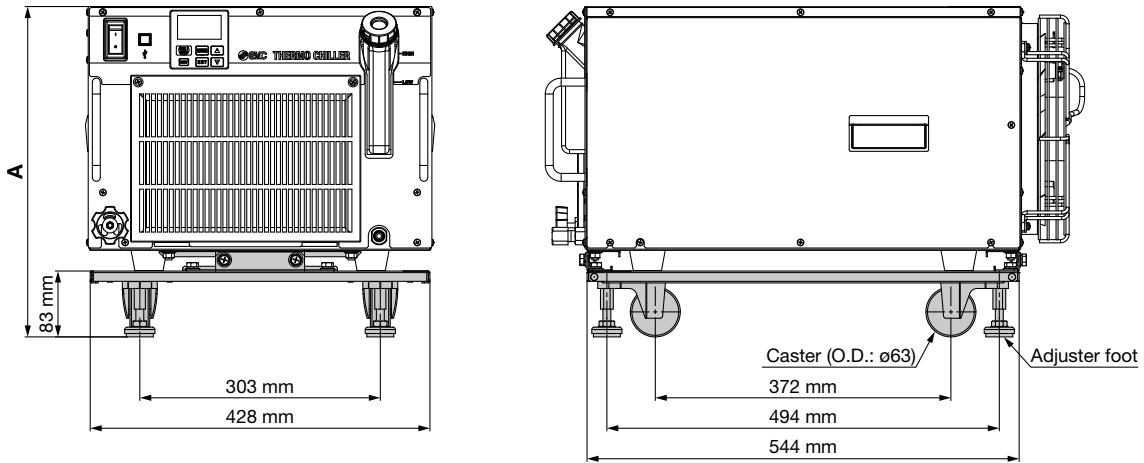

Mounting view

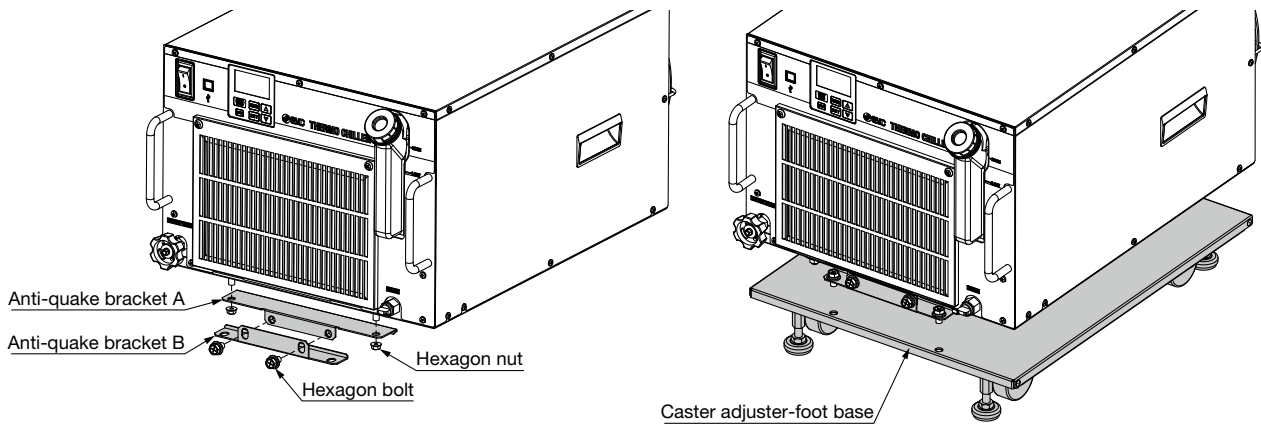

Mounting view

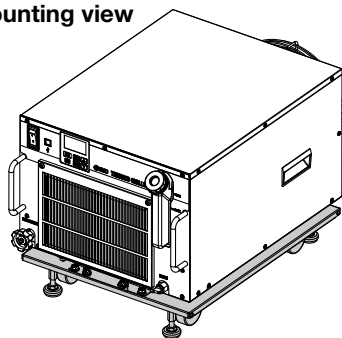

Parts List

Description	Qty.
Caster adjuster-foot base	1
Anti-quake bracket A	2
Anti-quake bracket B	2
Hexagon nut (M8)	4
Hexagon bolt (M8)	8
Mounting procedure manual	1

Cooling Capacity Calculation

Required Cooling Capacity Calculation

Example 1: When the heat generation amount in the user's equipment is known.

The heat generation amount can be determined based on the power consumption or output of the heat generating area — i.e. the area requiring cooling — within the user's equipment.*1

Q: Heat generation amount

① Derive the heat generation amount from the power consumption.

Power consumption P: 1000 [W]

$$Q = P = 1000 \text{ [W]}$$

Cooling capacity = Considering a safety factor of 20%,

$$1000 \text{ [W]} \times 1.2 = \boxed{1200 \text{ [W]}}$$

② Derive the heat generation amount from the power supply output.

Power supply output VI: 1.0 [kVA]

$$Q = P = V \times I \times \text{Power factor}$$

In this example, using a power factor of 0.85:

$$= 1.0 \text{ [kVA]} \times 0.85 = 0.85 \text{ [kW]} = 850 \text{ [W]}$$

Cooling capacity = Considering a safety factor of 20%,

$$850 \text{ [W]} \times 1.2 = \boxed{1020 \text{ [W]}}$$

③ Derive the heat generation amount from the output.

Output (shaft power, etc.) W: 800 [W]

$$Q = P = \frac{W}{\text{Efficiency}}$$

In this example, using an efficiency of 0.7:

$$= \frac{800}{0.7} = 1143 \text{ [W]}$$

Cooling capacity = Considering a safety factor of 20%,

$$1143 \text{ [W]} \times 1.2 = \boxed{1372 \text{ [W]}}$$

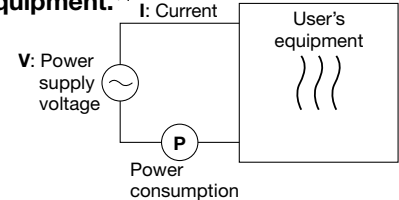

*1 The examples above calculate the heat generation amount based on the power consumption. The actual heat generation amount may differ due to the structure of the user's equipment. Be sure to check it carefully.

Example 2: When the heat generation amount in the user's equipment is not known.

Obtain the temperature difference between inlet and outlet by circulating the circulating fluid inside the user's equipment.

Heat generation amount by user's equipment Q: Unknown [W] ((J/s))

- Circulating fluid : Tap water*1
- Circulating fluid mass flow rate q_m : ($= \rho \times q_v \div 60$) [kg/s]
- Circulating fluid density ρ : 1 [kg/dm³]
- Circulating fluid (volume) flow rate q_v : 10 [dm³/min]
- Circulating fluid specific heat C : 4.2×10^3 [J/(kg·K)]
- Circulating fluid outlet temperature T₁ : 293 [K] (20 [°C])
- Circulating fluid return temperature T₂ : 295 [K] (22 [°C])
- Circulating fluid temperature difference ΔT : 2.0 [K] ($= T_2 - T_1$)
- Conversion factor: minutes to seconds (SI units): 60 [s/min]

*1 Refer to page 15 for the typical physical property value of tap water or other circulating fluids.

$$Q = q_m \times C \times (T_2 - T_1)$$

$$= \frac{\rho \times q_v \times C \times \Delta T}{60} = \frac{1 \times 10 \times 4.2 \times 10^3 \times 2.0}{60}$$

$$= 1400 \text{ [J/s]} \approx 1400 \text{ [W]}$$

Cooling capacity = Considering a safety factor of 20%,

$$1400 \text{ [W]} \times 1.2 = \boxed{1680 \text{ [W]}}$$

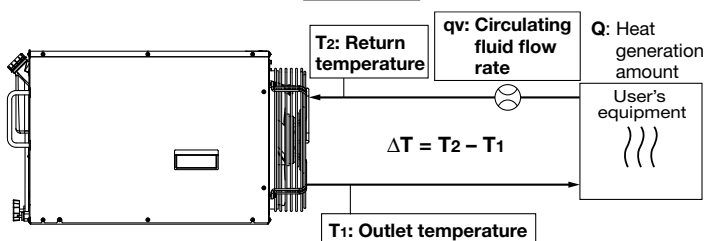

Example of conventional units (Reference)

- Heat generation amount by user's equipment Q: Unknown [cal/h] → [W]
- Circulating fluid : Tap water*1
- Circulating fluid weight flow rate q_m : ($= \rho \times q_v \times 60$) [kgf/h]
- Circulating fluid weight volume ratio γ : 1 [kgf/L]
- Circulating fluid (volume) flow rate q_v : 10 [L/min]
- Circulating fluid specific heat C : 1.0×10^3 [cal/(kgf·°C)]
- Circulating fluid outlet temperature T₁ : 20 [°C]
- Circulating fluid return temperature T₂ : 22 [°C]
- Circulating fluid temperature difference ΔT : 2.0 [°C] ($= T_2 - T_1$)
- Conversion factor: hours to minutes : 60 [min/h]
- Conversion factor: kcal/h to kW : 860 [(cal/h)/W]

$$Q = \frac{q_m \times C \times (T_2 - T_1)}{860}$$

$$= \frac{\gamma \times q_v \times 60 \times C \times \Delta T}{860}$$

$$= \frac{1 \times 10 \times 60 \times 1.0 \times 10^3 \times 2.0}{860}$$

$$= \frac{1200000 \text{ [cal/h]}}{860}$$

$$\approx 1400 \text{ [W]}$$

Cooling capacity = Considering a safety factor of 20%,

$$1400 \text{ [W]} \times 1.2 = \boxed{1680 \text{ [W]}}$$

* Calculation example for the temperature and flow rate based on customer's piping condition. For calculating the required cooling capacity based on the displayed value of temperature and flow rate in the chiller, fully close the bypass valve.

Required Cooling Capacity Calculation

Example 3: When there is no heat generation, and when cooling the object below a certain temperature and period of time.

Heat quantity by cooled substance (per unit time) **Q**: Unknown [W] [(J/s)]
 Cooled substance : Water
 Cooled substance mass **m** : (= $\rho \times V$) [kg]
 Cooled substance density ρ : 1 [kg/dm³]
 Cooled substance total volume **V** : 20 [dm³]
 Cooled substance specific heat **C** : 4.2 x 10³ [J/(kg·K)]
 Cooled substance temperature when cooling begins **To**: 305 [K] (32 [°C])
 Cooled substance temperature after t hour **Tt** : 293 [K] (20 [°C])
 Cooling temperature difference ΔT : 12 [K] (= **To** - **Tt**)
 Cooling time Δt : 900 [s] (= 15 [min])

* Refer to the following for the typical physical property values by circulating fluid.

$$Q = \frac{m \times C \times (T_0 - T_t)}{\Delta t} = \frac{\rho \times V \times C \times \Delta T}{\Delta t}$$

$$= \frac{1 \times 20 \times 4.2 \times 10^3 \times 12}{900} = 1120 \text{ [J/s]} \approx 1120 \text{ [W]}$$

Cooling capacity = Considering a safety factor of 20%,

$$1120 \text{ [W]} \times 1.2 = 1344 \text{ [W]}$$

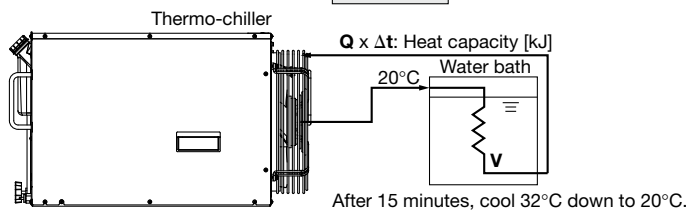

* This is the calculated value by changing the fluid temperature only.
 Thus, it varies substantially depending on the water bath or piping shape.

Example of conventional units (Reference)

Heat quantity by cooled substance (per unit time) **Q**: Unknown [cal/h] → [W]
 Cooled substance : Water
 Cooled substance weight **m** : (= $\rho \times V$) [kgf]
 Cooled substance weight volume ratio γ : 1 [kgf/L]
 Cooled substance total volume **V** : 20 [L]
 Cooled substance specific heat **C** : 1.0 x 10³ [cal/(kgf·°C)]
 Cooled substance temperature when cooling begins **To** : 32 [°C]
 Cooled substance temperature after t hour **Tt**: 20 [°C]
 Cooling temperature difference ΔT : 12 [°C] (= **To** - **Tt**)
 Cooling time Δt : 15 [min]
 Conversion factor: hours to minutes : 60 [min/h]
 Conversion factor: kcal/h to kW : 860 [(cal/h)/W]

$$Q = \frac{m \times C \times (T_0 - T_t)}{\Delta t \times 860} = \frac{\gamma \times V \times 60 \times C \times \Delta T}{\Delta t \times 860}$$

$$= \frac{1 \times 20 \times 60 \times 1.0 \times 10^3 \times 12}{15 \times 860}$$

$$\approx 1120 \text{ [W]}$$

Cooling capacity = Considering a safety factor of 20%,

$$1120 \text{ [W]} \times 1.2 = 1344 \text{ [W]}$$

Precautions on Cooling Capacity Calculation

1. Heating capacity

When the circulating fluid temperature is set above room temperature, it needs to be heated by the thermo-chiller. The heating capacity depends on the circulating fluid temperature. Consider the radiation rate and heat capacity of the user's equipment and check beforehand if the required heating capacity is provided.

2. Pump capacity

<Circulating fluid flow rate>

Circulating fluid flow rate varies depending on the circulating fluid discharge pressure. Consider the installation height difference between the thermo-chiller and the user's equipment, and the piping resistance such as circulating fluid pipings, or piping size, or piping curves in the machine. Check beforehand if the required flow is achieved, using the pump capacity curves.

<Circulating fluid discharge pressure>

Circulating fluid discharge pressure has the possibility to increase up to the maximum pressure in the pump capacity curves. Check beforehand if the circulating fluid pipings or circulating fluid circuit of the user's equipment are fully durable against this pressure.

Circulating Fluid Typical Physical Property Values

1. This catalog uses the following values for density and specific heat in calculating the required cooling capacity.

Density ρ : 1 [kg/dm³] (or, using conventional units, weight volume ratio $\gamma = 1$ [kgf/L])
 Specific heat **C**: 4.19 x 10³ [J/(kg·K)] (or, using conventional units, 1 x 10³ [cal/(kgf·°C)])

2. Values for density and specific heat change slightly according to temperature shown below. Use this as a reference.

Water

Physical property value Temperature	Density ρ [kg/dm ³]	Specific heat C [J/(kg·K)]	Conventional units	
			Weight volume ratio γ [kgf/L]	Specific heat C [cal/(kgf·°C)]
5°C	1.00	4.2 x 10 ³	1.00	1 x 10 ³
10°C	1.00	4.19 x 10 ³	1.00	1 x 10 ³
15°C	1.00	4.19 x 10 ³	1.00	1 x 10 ³
20°C	1.00	4.18 x 10 ³	1.00	1 x 10 ³
25°C	1.00	4.18 x 10 ³	1.00	1 x 10 ³
30°C	1.00	4.18 x 10 ³	1.00	1 x 10 ³
35°C	0.99	4.18 x 10 ³	0.99	1 x 10 ³
40°C	0.99	4.18 x 10 ³	0.99	1 x 10 ³

15% Ethylene Glycol Aqueous Solution

Physical property value Temperature	Density ρ [kg/dm ³]	Specific heat C [J/(kg·K)]	Conventional units	
			Weight volume ratio γ [kgf/L]	Specific heat C [cal/(kgf·°C)]
5°C	1.02	3.91 x 10 ³	1.02	0.93 x 10 ³
10°C	1.02	3.91 x 10 ³	1.02	0.93 x 10 ³
15°C	1.02	3.91 x 10 ³	1.02	0.93 x 10 ³
20°C	1.01	3.91 x 10 ³	1.01	0.93 x 10 ³
25°C	1.01	3.91 x 10 ³	1.01	0.93 x 10 ³
30°C	1.01	3.91 x 10 ³	1.01	0.94 x 10 ³
35°C	1.01	3.91 x 10 ³	1.01	0.94 x 10 ³
40°C	1.01	3.92 x 10 ³	1.01	0.94 x 10 ³

* Shown above are reference values.



HRRF Series Specific Product Precautions 1

Be sure to read this before handling the products. Refer to the back cover for safety instructions. For temperature control equipment precautions, refer to the "Handling Precautions for SMC Products" and the "Operation Manual" on the SMC website: <https://www.smcworld.com>

Design

Warning

- This catalog shows the specifications of a single unit.**
 - Check the specifications of the single unit (contents of this catalog) and thoroughly consider the adaptability between the user's system and this unit.
 - Although a protection circuit as a single unit is installed, prepare a drain pan, water leakage sensor, discharge air facility, and emergency stop equipment, depending on the user's operating conditions. Also, the user is requested to carry out a safety design for the whole system.
- When attempting to cool areas that are open to the atmosphere (tanks, pipes), plan your piping system accordingly.**
When cooling open-air external tanks, arrange the piping so that there are coil pipes for cooling inside the tanks and to carry back the entire flow volume of circulating fluid that is released.
- Use non-corrosive material for circulating fluid contact parts.**
The recommended circulating fluid is tap water or 15% ethylene glycol aqueous solution. Using corrosive materials such as aluminum or iron for fluid contact parts such as piping may cause clogging or leakage in the circulating fluid circuit. Therefore, take sufficient care when selecting fluid contact part materials such as piping.
- Design the piping so that no foreign matter enters the chiller.**
If foreign matter, such as scales in the piping, enters the circulating fluid, this may cause the pump to malfunction.
- This product uses a slightly flammable refrigerant (R454C). Avoid using this product in proximity to open flames. Ensure compliance with local laws and regulations regarding the use and application of this product.**



Transportation / Carriage / Movement

Warning

- This product cannot be transported by air as this product uses a slightly flammable refrigerant (R454C).
- This product is heavy. Pay attention to safety and the position of the product when it is transported, carried, and moved.
- Read the operation manual carefully before moving the product after unpacking.

Transportation / Carriage / Movement

Caution

- Never put the product down on its side as this may cause failure.**

The product will be delivered in the packaging shown below.

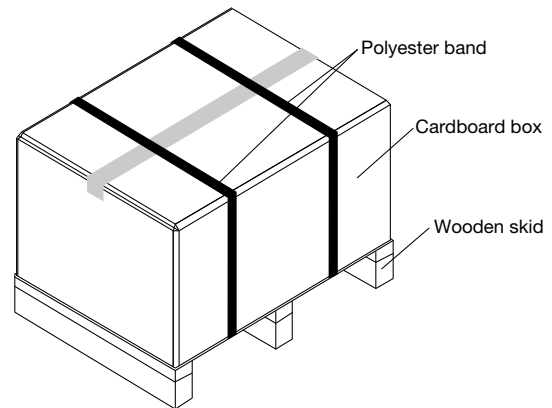

Model	Weight [kg]*1	Dimensions [mm]
HRRF012-A HRRF018-A	59	Height 575 x Width 610 x Depth 820
HRRF012-W HRRF018-W		

* For models with an option, the weight increases as shown below.

Option	Description	Product series	Additional weight
-DM	With electric conductivity control function, Applicable to DI water piping	All series	+1 kg
-M	Applicable to DI water piping	All series	Not changed
-T1	Inverter pump mounted	All series	-1 kg
-T	High-pressure pump mounted	All series	+5 kg
-Y	With feet/Without rack mounting brackets	All series	Not changed
-Z	Without either a flow sensor, water leakage sensor, particle filter, bypass valve or retaining clip	All series	-1 kg
-Z1	Without either a flow sensor or retaining clip	All series	Not changed

Caution

If this product is to be transported after delivery, please use the original packaging the product was delivered in. If other packaging is to be used, carefully package the product so as to prevent the product from incurring any damage during transport.



HRRF Series

Specific Product Precautions 2

Be sure to read this before handling the products. Refer to the back cover for safety instructions. For temperature control equipment precautions, refer to the “Handling Precautions for SMC Products” and the “Operation Manual” on the SMC website: <https://www.smcworld.com>

■ The circulating fluids listed below have been tested for thermo-chiller compatibility.

No.	Fluid	Manufacturer	Concentration
1	Dowcal™ 100 Heat Transfer Fluid	The Dow Chemical Company	Dilute to 30% in water
2	ControXid 1642	Oelheld GmbH	Ready to use
3	Hexid A4	Applied Thermal Control Limited	Ready to use
4	Coolflow IGE	Hydratech Division of Liquitherm Technologies Group Ltd	Dilute to 25% in water
5	NALCO® CCL105	Nalco Water, an Ecolab Company	Ready to use

- The chiller cooling capacity and pump capacity performance may change with using the fluids listed. Customers should verify the performances with the fluid and decide to use the fluid.
- Check the compatibility with the piping and the wetted parts of the customer's equipment before use.
- Check with the circulating fluid manufacturer for the following.
 - 1) Countries and regions where it can be obtained and used
 - 2) Handling and maintenance
 - 3) Safety data sheets
 - 4) Specifications and physical properties
- Concentration has to be value listed or less. Overly high concentrations can cause a pump overload. Low concentrations, however, can lead to freezing when circulating fluid temperature is 10°C or lower and cause the thermo-chiller to break down.
- Using the fluid listed for a long time, the chiller heat exchanger performance may be reduced due to additive deposits. It is recommended to regularly flush the inside of the piping and chiller with clean water.
- In the case of a mechanical seal pump, additive deposits may appear on the outside, it is not a malfunction.

■ Refrigerant with GWP reference

Refrigerant	Global Warming Potential (GWP)		
	Regulation (EU) 2024/573, AIM Act 40 CFR Part 84	Fluorocarbon Emissions Control Act (Japan)	
		GWP value labeled on products	GWP value to be used for reporting the calculated amount of leakage
R134a	1,430	1,430	1,300
R404A	3,922	3,920	3,940
R407C	1,774	1,770	1,620
R410A	2,088	2,090	1,920
R448A	1,386	1,390	1,270
R454C	146	145	146

- *1 This product is hermetically sealed and contains fluorinated greenhouse gases.
- *2 For refrigerant type used in this product, refer to the product specifications.

Temperature Control Equipment

These safety instructions are intended to prevent hazardous situations and/or equipment damage. These instructions indicate the level of potential hazard with the labels of “**Caution**,” “**Warning**” or “**Danger**.” They are all important notes for safety and must be followed in addition to International Standards (ISO/IEC), and other safety regulations.

Safety Instructions

- Danger** : **Danger** indicates a hazard with a high level of risk which, if not avoided, will result in death or serious injury.
- Warning** : **Warning** indicates a hazard with a medium level of risk which, if not avoided, could result in death or serious injury.
- Caution** : **Caution** indicates a hazard with a low level of risk which, if not avoided, could result in minor or moderate injury.

Compliance Requirements

1. The use of SMC products with production equipment for the manufacture of weapons of mass destruction (WMD) or any other weapon is strictly prohibited.
2. The exports of SMC products or technology from one country to another are governed by the relevant security laws and regulations of the countries involved in the transaction. Prior to the shipment of a SMC product to another country, assure that all local rules governing that export are known and followed.

Limited warranty and Disclaimer/ Compliance Requirements

The product used is subject to the following “Limited warranty and Disclaimer” and “Compliance Requirements”.

Read and accept them before using the product.

Limited warranty and Disclaimer

- 1. Period**
The warranty period of the product is 1 year in service or 1.5 years after the product is delivered, whichever is first.
- 2. Scope**
For any failure reported within the warranty period which is clearly our responsibility, replacement parts will be provided. In that case, removed parts shall become the property of SMC.
This guarantee applies only to our product independently, and not to any other damage incurred due to the failure of the product.
- 3. Content**
The following situations are out of scope of this warranty.
 1. The product was incorrectly installed or connected with other equipment.
 2. The product was modified or altered in construction.
 3. The failure was a secondary failure of the product caused by the failure of equipment connected to the product.
 4. The failure was caused by a natural disaster such as an earthquake, typhoon, or flood, or by an accident or fire.
 5. The failure was caused by operation different from that shown in the Operation Manual or outside of the specifications.
 6. The checks and maintenance specified (daily checks and regular checks) were not performed.
 7. The failure was caused by the use of circulating fluid or facility water other than those specified.
 8. The failure occurred naturally over time (such as discoloration of a painted or plated face).
 9. The failure does not affect the functioning of the product (such as new sounds, noises and vibrations).
 10. The failure was due to the “Installation Environment” specified in the Operation Manual.
- 4. Disclaimer**
 1. Expenses for daily and regular checks
 2. Expenses for repairs performed by other companies
 3. Expenses for transfer, installation and removal of the product
 4. Expenses for replacement of parts other than those in this product, or for the supply of liquids
 5. Inconvenience and loss due to product failure (such as telephone bills, compensation for workplace closure, and commercial losses)

For warranted repair, please contact the supplier you purchased this product from.

Warning

1. The compatibility of the product is the responsibility of the person who designs the equipment or decides its specifications.

Since the product specified here is used under various operating conditions, its compatibility with specific equipment must be decided by the person who designs the equipment or decides its specifications based on necessary analysis and test results. The expected performance and safety assurance of the equipment will be the responsibility of the person who has determined its compatibility with the product. This person should also continuously review all specifications of the product referring to its latest catalog information, with a view to giving due consideration to any possibility of equipment failure when configuring the equipment.

2. Only personnel with appropriate training should operate machinery and equipment.

The product specified here may become unsafe if handled incorrectly. The assembly, operation and maintenance of machines or equipment including our products must be performed by an operator who is appropriately trained and experienced.

3. SMC products cannot be used beyond their specifications. They are not developed, designed, and manufactured to be used under the following conditions or environments. Use under such conditions or environments is not allowed.

1. Conditions and environments outside of the given specifications, or use outdoors or in a place exposed to direct sunlight.
2. Use for nuclear power, railways, aviation, space equipment, ships, vehicles, military application, equipment affecting human life, body, and property, combustion equipment, entertainment equipment, emergency shut-off circuits, press clutches, brake circuits, safety equipment, etc., and use for applications that do not conform to standard specifications such as catalogs and operation manuals.
3. Use for interlock circuits, except for use with double interlock such as installing a mechanical protection function in case of failure. Please periodically inspect the product to confirm that the product is operating properly.

Caution

SMC develops, designs, and manufactures products to be used for automatic control equipment, and provides them for peaceful use in manufacturing industries.

Use in non-manufacturing industries is not allowed.

Products SMC manufactures and sells cannot be used for the purpose of transactions or certification specified in the Measurement Act of each country.

The new Measurement Act prohibits use of any unit other than SI units in Japan.

 **Safety Instructions** Be sure to read the “Handling Precautions for SMC Products” (M-E03-3) and “Operation Manual” before use.