

Valve Manifold Integrated with Ejector System

New



Compact All-in-One Manifold

The devices have been integrated into one for applications in which an actuator and vacuum suction are used together.

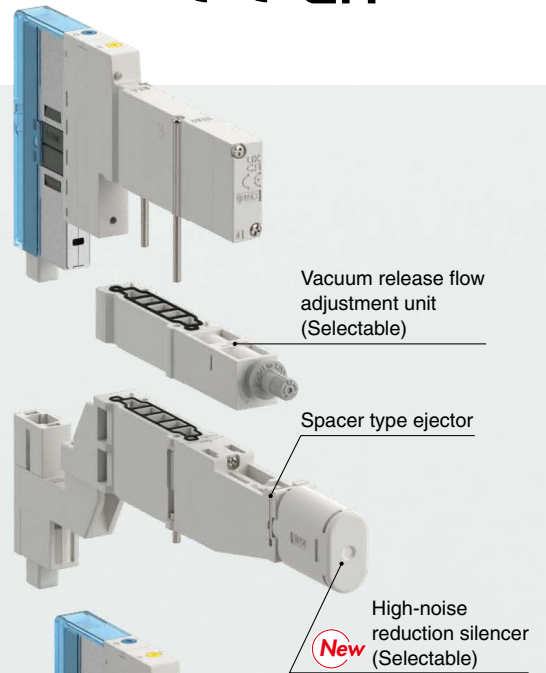

Compatible Protocol

EtherCAT

IO-Link

PROFINET

EtherNet/IP

Material handling

Metal workpiece with holes and complicated shape

Magnet gripper + Vacuum pad, etc.

Small robot

Air gripper + Vacuum pad, etc.

Pick and place

Slide table + Vacuum pad, etc.

Small box making process

Cartoner

Cylinder + Vacuum pad, etc.

JSY1000-E Series

Wiring/Piping Saving through Use of All-in-One Manifold



A vacuum release flow adjustment unit has been added.

* This is an option for the spacer type ejector.

By combining a 3-position closed center valve and a 4-position 5-port valve (supply pressure vacuum release valve), the vacuum release air flow rate can be adjusted according to the application.

- Aids in preventing workpieces from being blown away
- No installation space required due to being stacked on the spacer type ejector
- Easy tool-less one push-lock

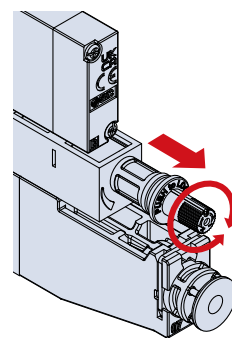

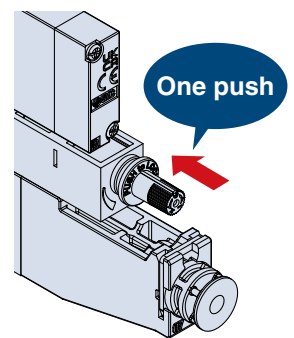

When adjusting the flow rate
(Unlocked)

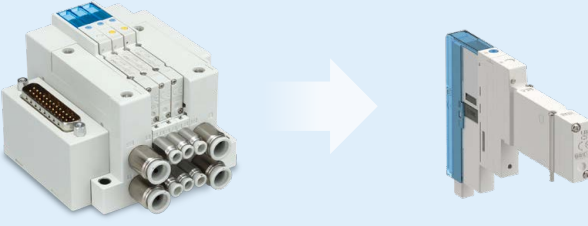

Locked

The devices for control of actuators and vacuum suction are integrated into one to reduce the wiring and piping.

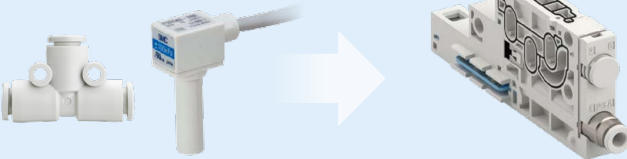
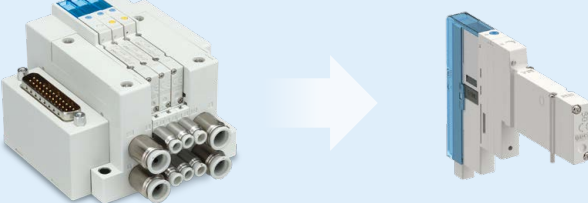
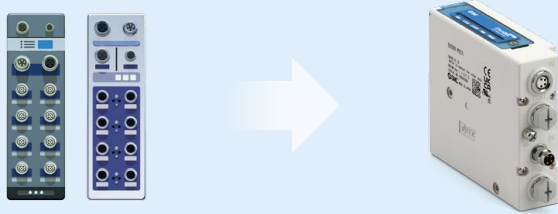
<p>Vacuum Generation (5-port valve/ Ejector)</p>		<p>4-position 5-port 2-position single 2-position double 3-position closed center p. 12</p>
		<p>Spacer Type Ejector Selectable With check valve, With silencer, With ø6 One-touch fitting (With ejector exhaust port) p. 17</p>
<p>Vacuum Release Air Adjustment (Speed controller)</p>		<p>New Vacuum release flow adjustment unit (Selectable) p. 17</p>
<p>Suction Verification (Pressure sensor)</p>		<p>Manifold base with built-in pressure sensor p. 31</p>
<p>Actuator Drive (5-port valve)</p>		<p>2-position single 2-position double 3-position 4-position dual 3-port</p>
<p>Control Signal Communication (Input/Output Unit)</p>		<p>Integrated dedicated SI Unit (For Input/Output) p. 38</p>

Related Product

Protection of valve/ejector and improved ease of maintenance
In-line Air Filter **ZFC Series**



More information can be viewed here.

Space Saving and Weight Reduction

The devices for control of actuators and vacuum suction are integrated into one to reduce the installation area and weight.

Installation area

64%reduction

JSY1000-E: 18,587 mm², Existing model: 51,287 mm²

Weight

42%reduction

JSY1000-E: 1,100 g, Existing model: 1,883 g

Conditions for comparison

For 4-station ejector and 8-station solenoid valve manifold

Each of the conventional products consists of a set of components that fulfill the functions of a single all-in-one manifold.

* Excludes wiring and piping

[Image]

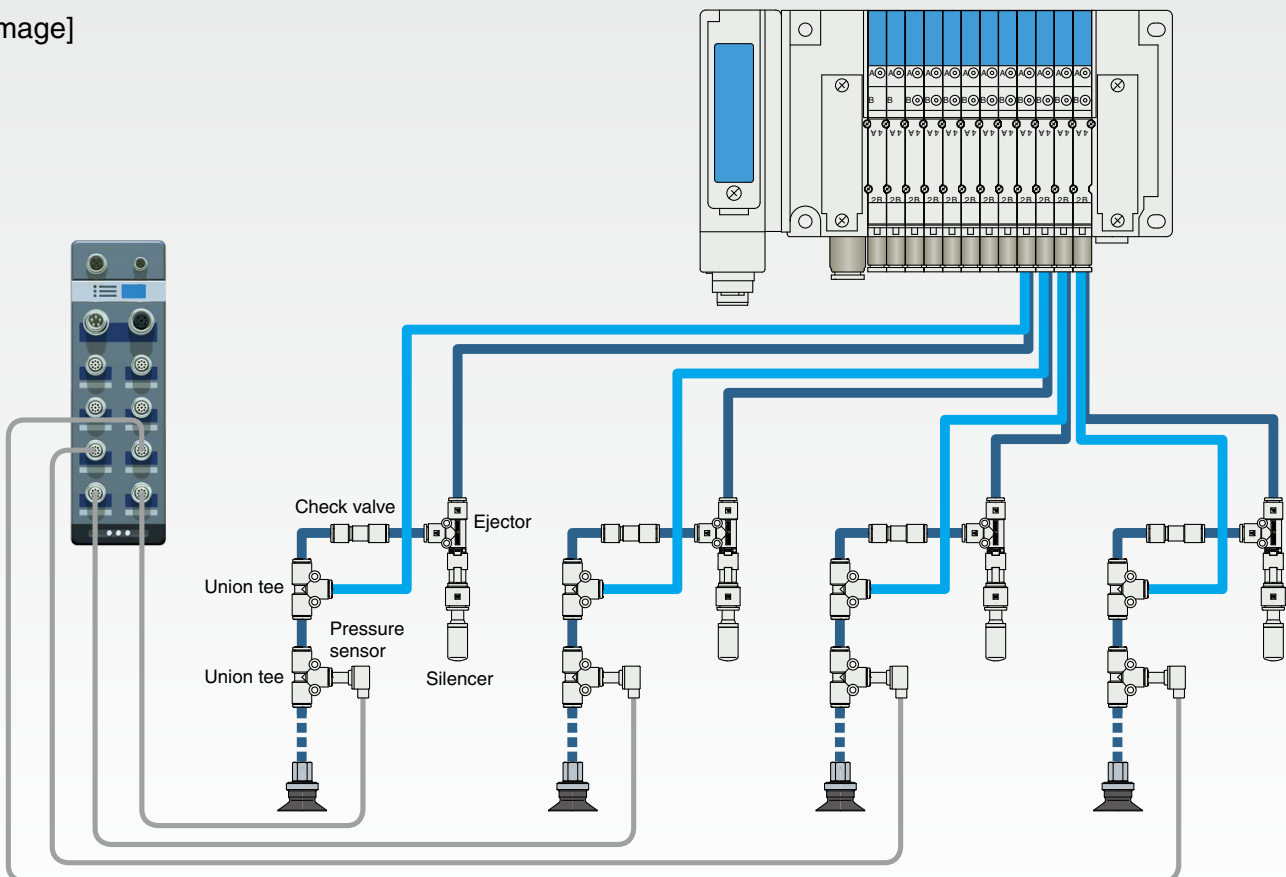

through Use of All-in-One Manifold

JSY1000-E Series

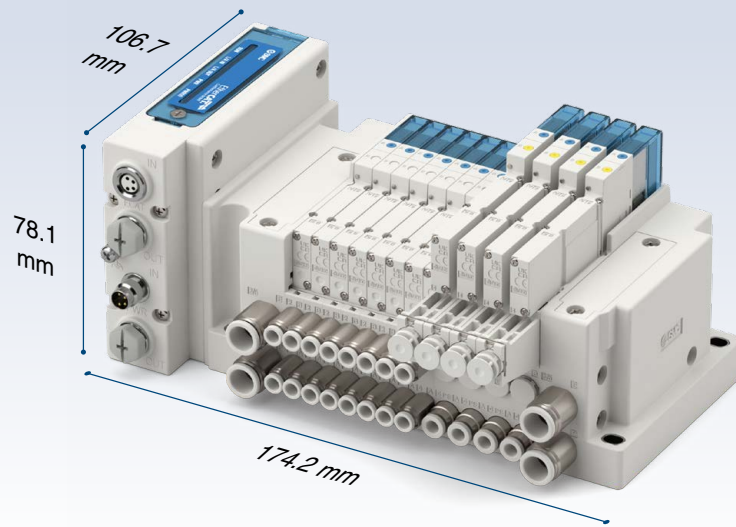

Existing Model

[Component]

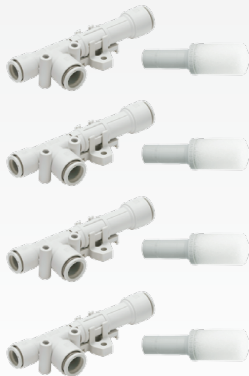
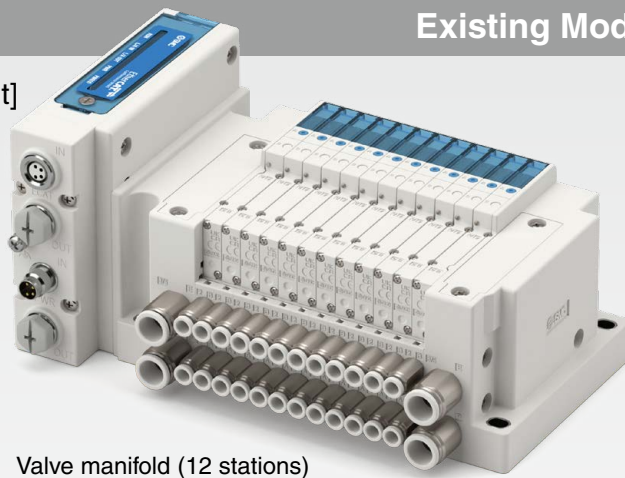

Energy Saving Function

Reduces air consumption at the time of vacuum generation in spacer type ejectors by combining the ejector with a check valve and built-in pressure sensor

CO₂ emissions (Air consumption)

90% reduction *1

*1 Based on SMC's measurement conditions

Energy saving function ON

Air is supplied and exhausted intermittently when the vacuum decreases.

Energy saving function OFF

Air is supplied and exhausted continuously during the adsorption of the workpiece.

Target ejector models

JSY11M-EP-3VA-□S□

p. 23

JSY11M-EP-4VA-□S□

*2 Specifications of supply valves of selectable ejectors

N.C.: 3-position closed center

N.O.: 4-position 5-port valve*3

*3 However, as the operation switches to N.C. operation at the time of vacuum release, the ejector will not operate.
(With supply valves including conventional N.O. three-port valve, vacuum is generated with no energization at the time of vacuum release to consume air.)

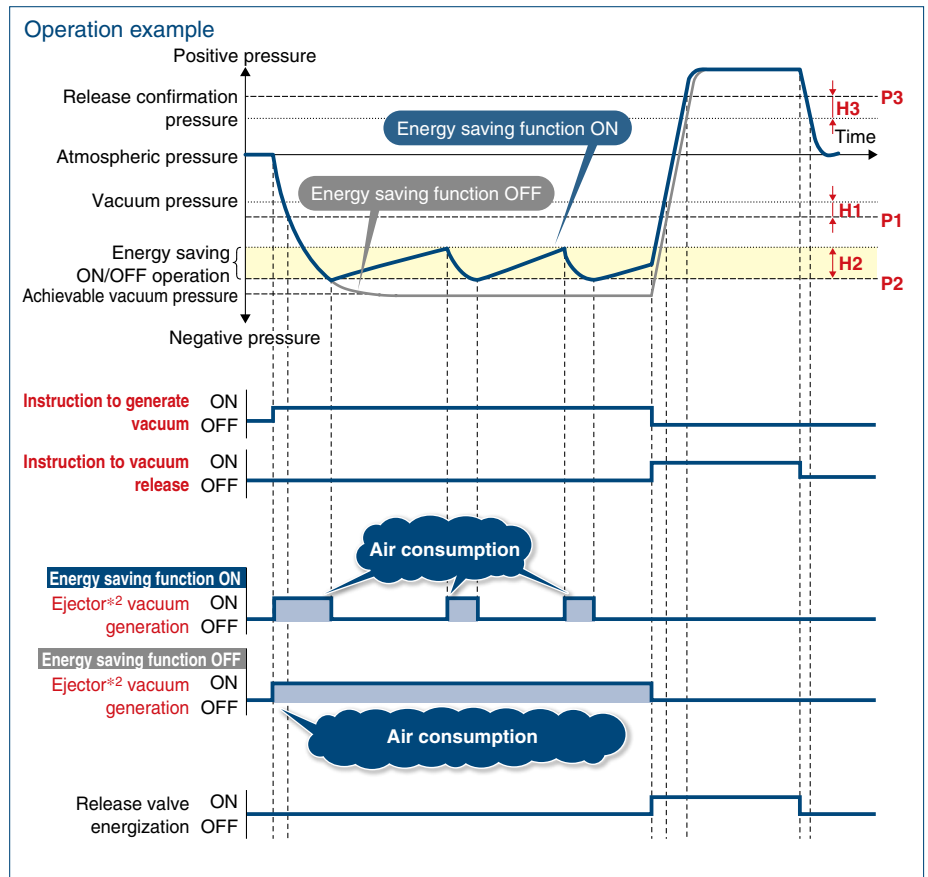

Valve Protection

If the supply valve reaches the set number of operations while the energy-saving function is in use, the energy-saving function automatically turns OFF and switches to continuous adsorption to prevent excessive valve operation.

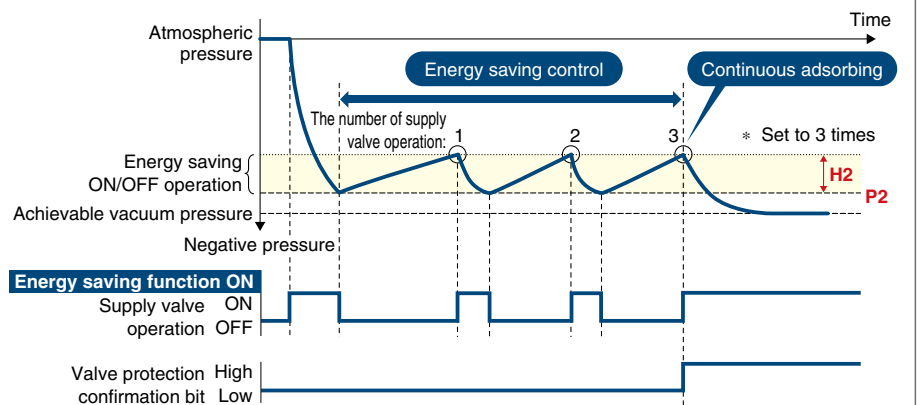

New Pilot Air Control Unit

A single-station unit, in which a dedicated manifold block and a 3-port valve are combined, has the following features:

- Enables restriction of the valve operation
 - In the event of emergency stop or in other occasions, the product discharges the pilot pressure in the manifold to disable the electrical signal from switching the valve.
- Contributes to fast recovery at the time of restoration
 - As the valve cannot be switched due to the operation restriction, it is possible to immediately return to the state from before the emergency stop (for two-position single and double).
- Enables remote monitoring of the restriction status of valve operation
 - The dedicated manifold block is incorporated with a pressure sensor.
 - It is possible to confirm the supply and discharge of pilot pressure via the network.
- Allows selection and mixed mounting of valves subject to operation restrictions on the same manifold
 - Valves subject to operation restriction: valves with external pilot specifications
 - Valves not subject to operation restriction: valves with internal pilot specifications

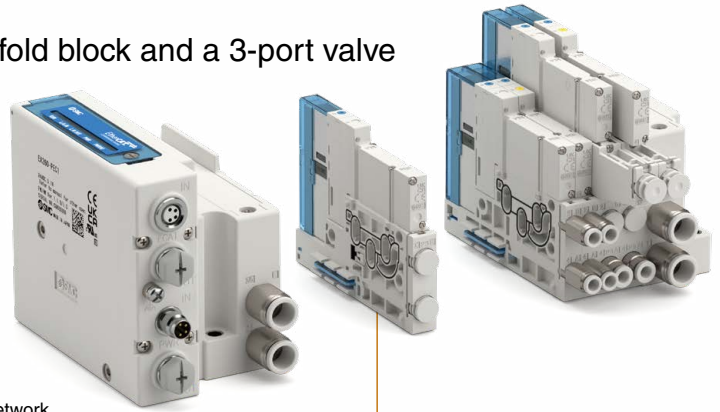

Pilot air control unit

Circuit Example

The pilot air control unit supplies/discharges pilot air only to/from the valves with external pilot specifications mounted on the manifold. Discharging the pilot air when stopped prevents electrical signal and manual operations from being performed.*1 In addition, the pilot air control unit also features a built-in pressure sensor, which allows for the monitoring of the pilot air supply status.

*1 Note that when a 3-position or 4-position 5-port valve is energized, the valve switches to the neutral position by means of the return spring that is built into the valve.

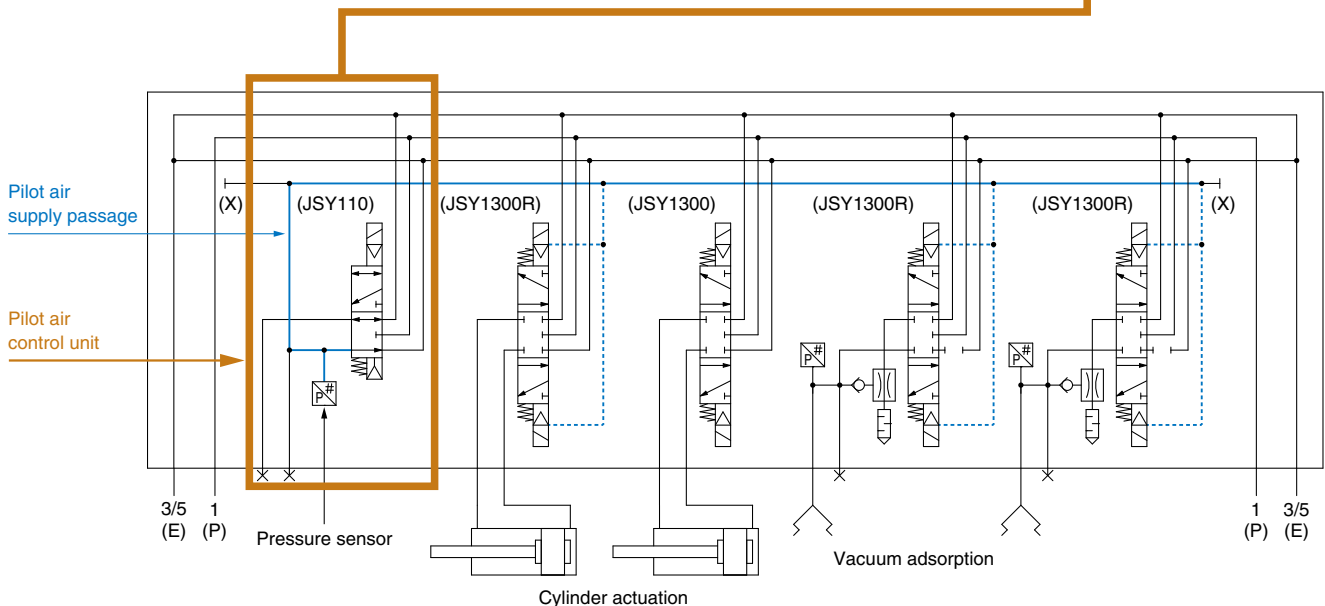
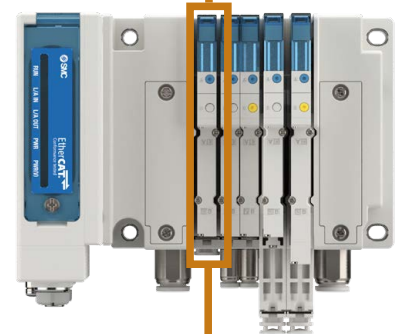

Spacer Type Ejector

Combination of a newly-developed spacer type ejector and a solenoid valve, makes it possible to selectively use ejectors in accordance with the application.

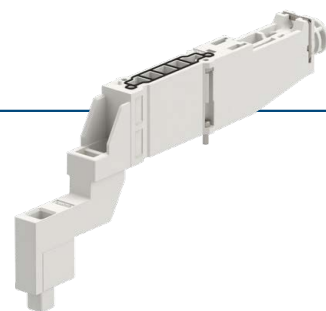

Spacer Type Ejector/Solenoid Valve [Variations/Combinations]

Combination specifications	N.O. Supply valve/N.C. Release valve		N.O. Supply valve/N.C. Release valve	N.O. Supply valve/N.C. Supply valve	
Solenoid valve used	4-position 5-port supply pressure vacuum release	4-position 5-port atmospheric pressure vacuum release	3-position closed center	2-position double	2-position single
Symbol					



4-Position 5-Port Valve

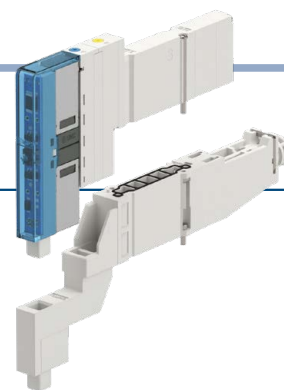

Combination with spacer type ejector can achieve the following:

- Air-saving and stable workpiece holding, and positive workpiece release with only a single station.
 - Vacuum suction and vacuum holding is achieved through energy saving control by the dedicated SI Unit.
 - It is possible to select supply pressure type or atmospheric pressure type for the vacuum release air supply. (Vacuum release air can be adjusted via the vacuum release flow adjustment unit.)
- When stopped midway, reliable workpiece holding and release is possible.
 - Supply valve operation with Normally Open (N.O.) specification
 - Atmospheric release takes place when the vacuum release air supply stops (standby).

Stopping during adsorption transfer (A on)	Releasing of workpiece at the time of vacuum release (B on)	Stopping during vacuum release (B on)
<p>Prevents the sudden dropping of workpieces</p> <p>The N.O. specification allows for the mode to switch to vacuum generation when the power is turned OFF to maintain suction of the workpiece.</p>	<p>Prevents dropping or blowing away of workpiece</p> <p>With a supply pressure vacuum release type, the built-in restrictor restricts the vacuum release air flow to stably release the workpiece.</p>	<p>Prevents holding of workpiece</p> <p>Even when the power is turned OFF during vacuum release, the workpiece can still be released via atmospheric release.</p>

4-position 5-port valve in conducted state	→ → → → →			
	(A on→) A off	A on	B on	B off
Spool valve position	A side neutral	A side on	B side on	B side neutral
Ejector/Valve status	Vacuum generation ←	Vacuum holding (Energy saving)	Vacuum release	Vacuum release air stop/ Atmospheric release (Standby)
When stopped midway	Vacuum generation (A off)		Vacuum release air stop/Atmospheric release (B off)	

Energy saving function
 When the vacuum pressure reaches the set pressure, this function stops the ejector and retains the vacuum state, thus contributing to reduction of air consumption by the ejector. [p. 5](#)

Vacuum release air control
 With the supply pressure vacuum release type, it is possible to switch the vacuum release air supply between the supply pressure and atmospheric pressure (atmospheric release).



CONTENTS

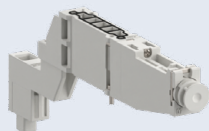

Valve Manifold Integrated with Ejector System JSY1000-E Series

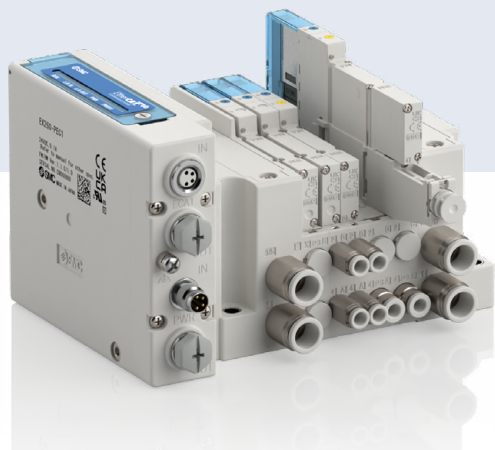

Optimum Actuation Size Chart of Air Cylinder	p. 9
Common Specifications	p. 11
Valve Specifications	p. 12
Valve Construction	p. 13

Plug-in Connector Connecting Base

Manifold Specifications	p. 15
Manifold Weight	p. 15
Manifold Flow Rate Characteristics	p. 15
Pilot Air Control Unit	p. 15
Connector Wiring Layout	p. 16

Spacer Type Ejector

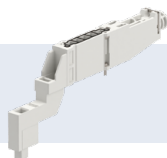

Ejector Specifications	p. 17
Ejector Weight	p. 17
Supply Valve/Release Valve Flow Rate Characteristics	p. 17
Exhaust Characteristics/Flow Rate Characteristics	p. 17
Construction	p. 18
Circuit Diagrams	p. 18

[Atmospheric Pressure] Vacuum Release Specification 4-Position 5-Port Valve/Spacer Type Ejector Operation Diagrams	p. 19
[Supply Pressure] Vacuum Release Specification 4-Position 5-Port Valve/Spacer Type Ejector Operation Diagrams	p. 20

Specific Product Precautions	p. 40
------------------------------	-------

Valve Manifold Integrated with Ejector System

Plug-in Connector Connecting Base (EX260)

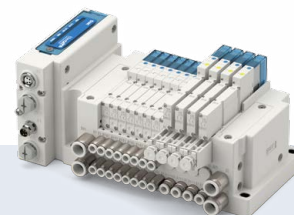

How to Order Manifolds	p. 21
How to Order Valves (With mounting screw)	p. 22
How to Order Spacer Type Ejector (With mounting screw)	p. 23
How to Order Manifold Assembly	p. 24
Dimensions	p. 25

Manifold Exploded View

Type 10: How to Increase Connector Type Manifolds	p. 29
For the JJ5SY1-E10	p. 30
Manifold Parts Nos.	p. 30

One-touch Fittings, Plug, Clip, Port Plate, Tube Releasing Tool	p. 33
Manifold Options	p. 34
Made to Order	p. 37

EX260 Series SI Unit/Pressure Sensor



How to Order SI Units	p. 38
SI Unit Specifications	p. 38
Pressure Sensor Specifications	p. 38
Dimensions	p. 39
Parts Description	p. 39
LED Indicator	p. 39

Chart

Valve

Manifold

Spacer Type Ejector

Operation Diagrams

JSY1000-E

Manifold Exploded View

Fittings, Replacement Parts, Tools

Manifold Options

Made to Order

EX260

Specific Product Precautions

Optimum Actuation Size Chart of Air Cylinder

For JSY1000, A, B port: $\phi 4$

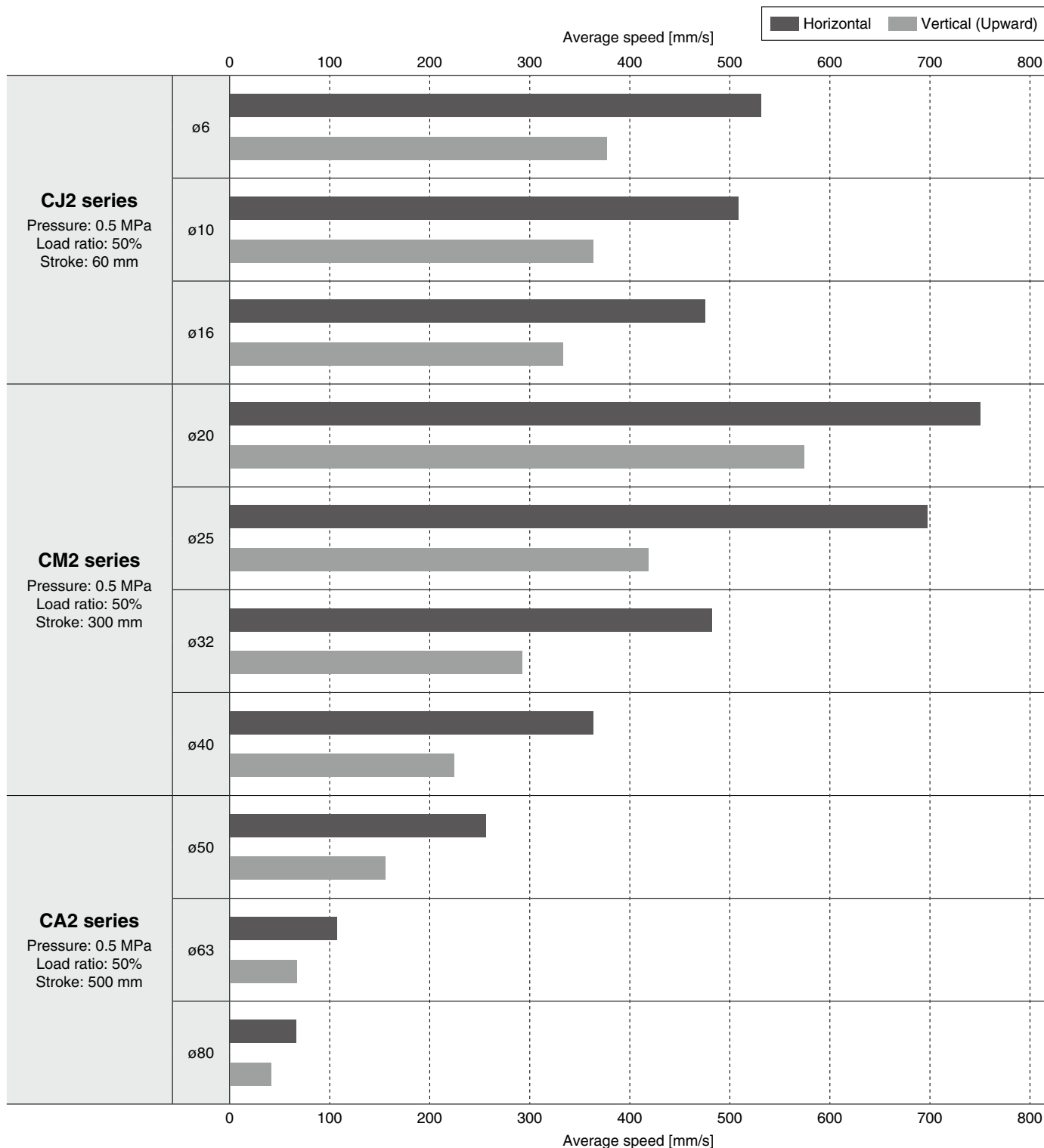

- * Values at extension of a directly coupled cylinder when meter-out speed controllers are used with the needle full open.
- * The average speed of the cylinder is obtained by dividing the stroke by the total stroke time.
- * Formula for load ratio: $\text{Load ratio} = ((\text{Load mass} \times 9.8) / \text{Theoretical output}) \times 100\%$
- * Cylinder for horizontal use are based on the coefficient of rolling friction 0.1.
- * Operating piston speed is different depending on the applicable cylinder. Refer to the cylinder catalog for details.

Optimum Actuation Size Chart of Air Cylinder

For JSY1000, A, B port: $\phi 6$

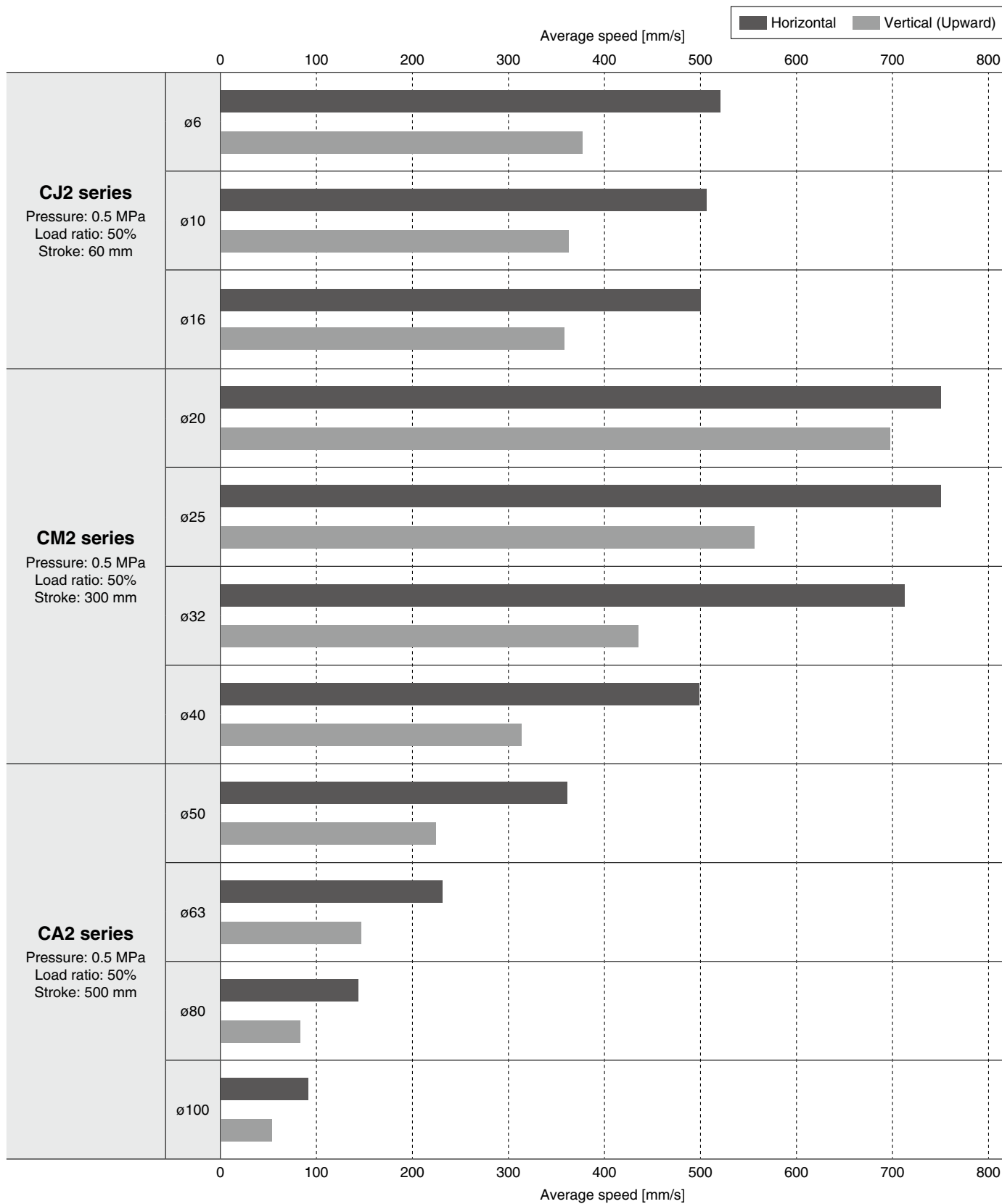

- * Values at extension of a directly coupled cylinder when meter-out speed controllers are used with the needle full open.
- * The average speed of the cylinder is obtained by dividing the stroke by the total stroke time.
- * Formula for load ratio: $\text{Load ratio} = ((\text{Load mass} \times 9.8) / \text{Theoretical output}) \times 100\%$
- * Cylinder for horizontal use are based on the coefficient of rolling friction 0.1.
- * Operating piston speed is different depending on the applicable cylinder. Refer to the cylinder catalog for details.

Chart

Valve

Manifold

Spacer Type Ejector

Operation Diagrams

JSY1000-E

Manifold Exploded View

Fittings, Replacement Parts, Tools

Manifold Options

Made to Order

EX260

Specific Product Precautions

JSY1000-E Series

Common Specifications

Common Specifications

Fluid		Air	
Internal pilot operating pressure range [MPa]	2-position single	0.15 to 0.7 (0.6)*1	
	2-position double	0.1 to 0.7 (0.6)*1	
	3-position	0.2 to 0.7 (0.6)*1	
	4-position dual 3-port	0.15 to 0.7	
	4-position 5-port	0.2 to 0.6*2	
	2-position 3-port	0.25 to 0.7	
External pilot*3 operating pressure range [MPa]	Operating pressure range		
	Pilot pressure range	2-position single	-100 kPa to 0.7 (0.1 to 0.6)*4
		2-position double	
		3-position	
		4-position 5-port	
Ambient and fluid temperatures [°C]		-5 to 50 (No freezing)	
Lubrication		Not required	
Mounting orientation*5		Unrestricted	
Impact/Vibration resistance*5 m/s ²		150/30	
Enclosure		IP40	

*1 The values in the parentheses indicate the maximum operating pressures when the spacer type ejector is mounted.

*2 The 4-position 5-port valve is dedicated for mounting on the spacer type ejector.

*3 External pilot specification is not applicable for 4-position dual 3-port valves and 2-position 3-port valves.

*4 The values in the parentheses indicate the operating pressures range when the spacer type ejector is mounted.

*5 Impact resistance: No malfunction occurred when tested in the axial direction and at a right angle to the main valve and armature in both an energized and a de-energized state, once in each condition. (Value in the initial state)

Vibration resistance: No malfunction occurred in a one-sweep test between 45 and 2000 Hz in the axial direction and at a right angle to the main valve and armature in both an energized and a de-energized state, once in each condition. (Value in the initial state)

JSY1000-E Series Valve Specifications

Valve Specifications

Valve type		Rubber seal
Max. operating frequency [Hz]	2-position single	5
	2-position double	
	4-position dual 3-port	
	2-position 3-port	3
	3-position	
	4-position 5-port	
Manual override		Non-locking push type
		Push-turn locking slotted type
Pilot exhaust type	Internal pilot	Individual exhaust
	External pilot	
Coil rated voltage [DC]		24 V
Allowable voltage fluctuation [V]		±10% of the rated voltage
Power consumption [W]	With power-saving circuit	0.2*1 [Inrush 0.5, Holding 0.2]
Surge voltage suppressor		Diode
Indicator light		LED

*1 The JSY1000 series is only available as the power-saving type. Standard type (without power-saving circuit) cannot be selected.

Response Time

Series	Model	Type of actuation	Response time [ms]*1		
			With light/surge voltage suppressor		
			Z type		
JSY1000	JSY1100	2-position single	15		
	JSY1200	2-position double	7		
	JSY13/4/500	3-position	16		
	JSY1A/B/C00	4-position dual 3-port	19		
	JSY1E/P00	4-position 5-port	A on	14	
			A off	37	
			B on	11	
			B off*2	51	
JSY110-B	2-position 3-port	18			

*1 Based on the dynamic performance test, JIS B 8419-2010 (Coil temperature: 20°C, at rated voltage)

*2 B off response time is not applicable to JSY1E00 (atmospheric pressure vacuum release specifications).

Valve Weight

Valve model	Type of actuation		Weight [g]
JSY1□00	2-position	Single	24
		Double	27
		3-port	24
	3-position	Closed center	30
		Exhaust center	
		Pressure center	
	4-position	Dual 3-port	27
		5-port	30

Chart

Valve

Manifold

Spacer Type
Ejector

Operation
Diagrams

JSY1000-E

Manifold
Exploded View

Fittings,
Replacement Parts,
Tools

Manifold
Options

Made to Order

EX260

Specific Product
Precautions

JSY1000-E Series Valve Construction

Rubber Seal

2-position single

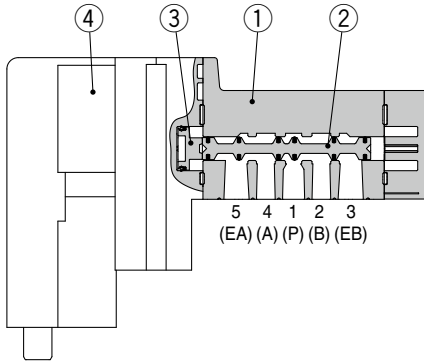

2-position single

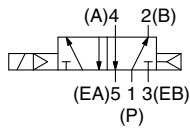

2-position double

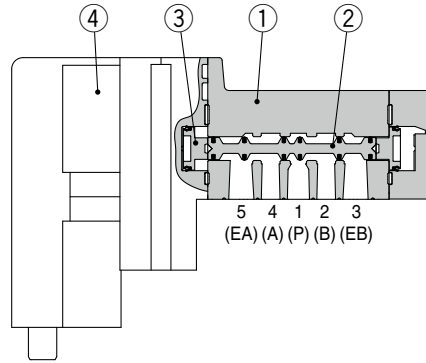

2-position double

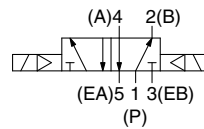

3-position closed center/exhaust center/pressure center

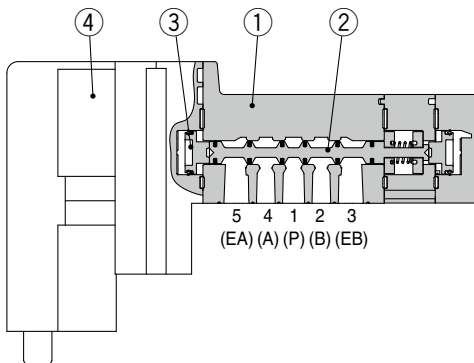

3-position closed center

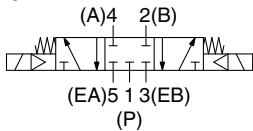

3-position exhaust center

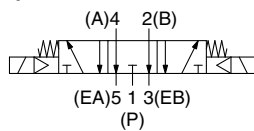

3-position pressure center

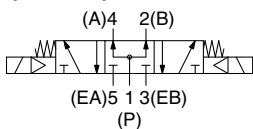

4-position dual 3-port

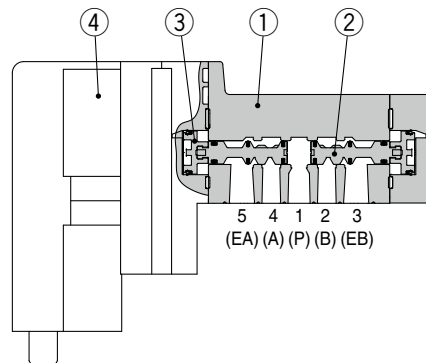

4-position dual 3-port

N.C. x 2 pcs.

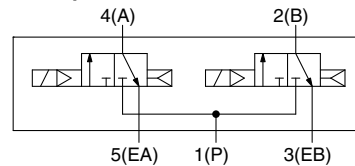

N.O. x 2 pcs.

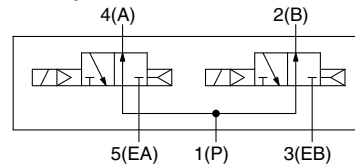

N.C., N.O. x 1 pc. of each

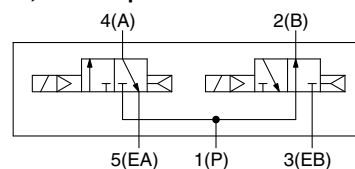

Rubber Seal

2-position 3-port

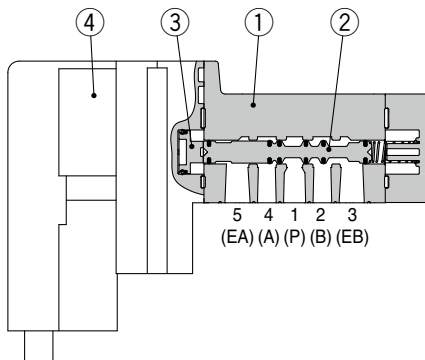

2-position 3-port valve

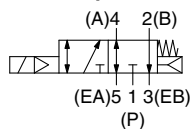

4-position 5-port

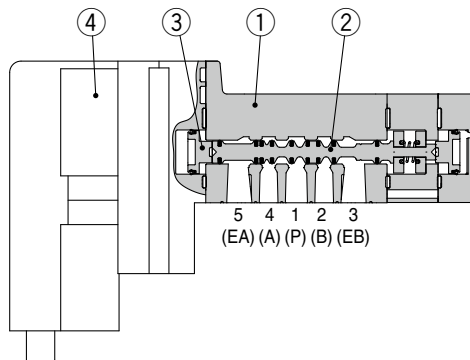

4-position 5-port valve

Atmospheric pressure vacuum release specification

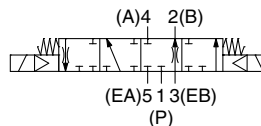

Supply pressure vacuum release specification

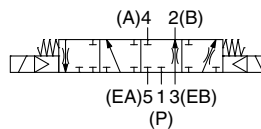

Component Parts

No.	Description	Material
1	Body	Aluminum die-casted
2	Spool valve	Aluminum/HNBR (4-position dual 3-port valve: Resin/HNBR)
3	Piston	Resin
4	Pilot valve assembly	—

* The pilot valve of the JSY1000 cannot be removed. This is irreplaceable.

Chart

Valve

Manifold

Spacer Type
Ejector

Operation
Diagrams

JSY1000-E

Manifold
Exploded View

Fittings,
Replacement Parts,
Tools

Manifold
Options

Made to Order

EX260

Specific Product
Precautions

JSY1000-E Series

Valve Manifold Integrated with Ejector System

Type 10

Plug-in Connector Connecting Base

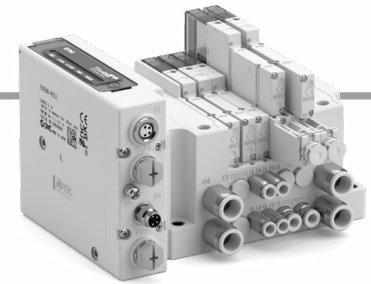

Manifold Specifications

Model		Serial wiring	
		S□ type EX260 dedicated to valve manifold integrated with ejector system	
Manifold type		Plug-in connector connecting base, Side ported	
SUP/EXH port type		Common SUP/EXH (Common for the 3/5 port)	
Valve stations		2 to 24 stations	
Internal wiring		Negative common	
Built-in pressure sensor		1 to 5 units	
Port size	1(P), 3/5(E) port	ø8 One-touch fitting	
	4(A), 2(B) port	ø2 One-touch fitting, ø4 One-touch fitting, ø6 One-touch fitting	

Manifold Weight

Model		① Per station	② Wiring	
			Serial wiring S□ type (EX260)	
JSY1000	6.5 mm pitch	21.3	448	
	9 mm pitch	26.9		

Formula for manifold weight*1

$$W = ① \times n1 + ② \quad (n1: \text{stations})$$

*1 Weight: "W" is the value for the internal pilot specification, the max. fitting size, and the manifold only. The valve weight is not included. To calculate the weight of a product mounted with valves, add the weight of the valves on stations based on the valve weights on page 12, and to calculate the weight of a product mounted with spacer type ejectors, add the weight of spacer type ejectors on stations based on the spacer type ejector weights on page 17.

Manifold Flow Rate Characteristics

Model	Port size		Valve flow rate characteristics			
	1, 3/5 (P, E)	4, 2 (A, B)	1 → 4/2 (P → A/B)		4/2 → 3/5 (A/B → E)	
			C [dm³/(s·bar)]	b	C [dm³/(s·bar)]	b
JJ5SY1-E10	C8	C4	0.63	0.46	0.87	0.47
		C6	0.96	0.30	0.91	0.48

Pilot Air Control Unit

The pilot air control unit supplies/discharges pilot air only to/from the valves with external pilot specifications mounted on the manifold. Discharging the pilot air when stopped prevents electrical signal and manual operations from being performed.*1 In addition, the pilot air control unit also features a built-in pressure sensor, which allows for the monitoring of the pilot air supply status.

*1 Note that when a 3-position or 4-position 5-port valve is energized, the valve switches to the neutral position by means of the return spring that is built into the valve.



Circuit example

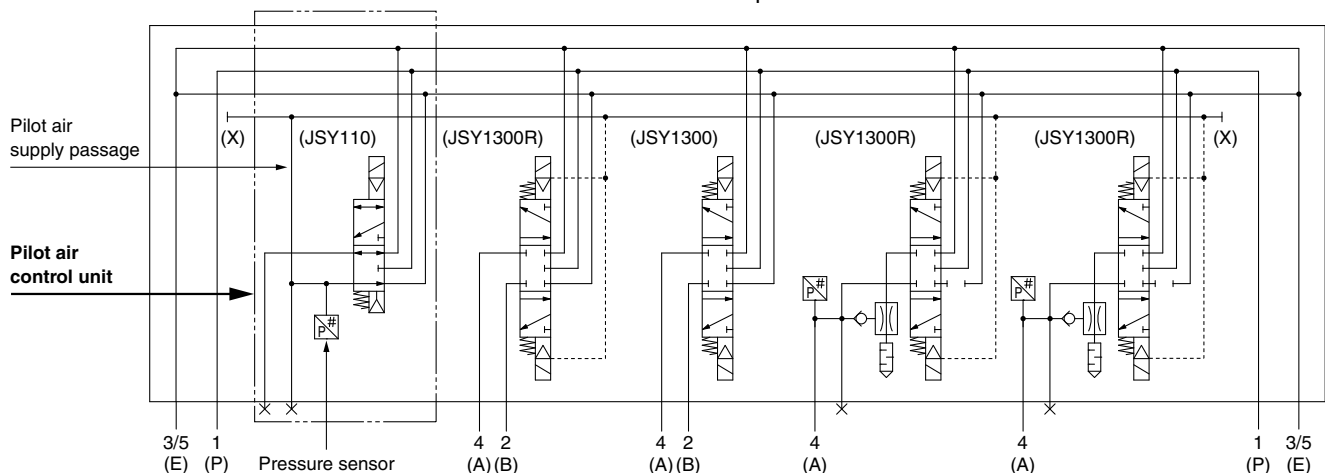

Connector Wiring Layout

Additional valves are sequentially assigned pins on the serial unit. This makes it completely unnecessary to disassemble the connector unit.

The built-in pressure sensor as well, assign sensor signals to the serial unit side in order in the same manner. When a manifold block not equipped with a pressure sensor is present, connect the sensor signal wiring to the subsequent manifold block as is. The wiring of the pilot air control unit is single wiring even with the double wiring specifications.

■ For all double wiring with pilot air control unit (Manifold specification sheet is not necessary.)

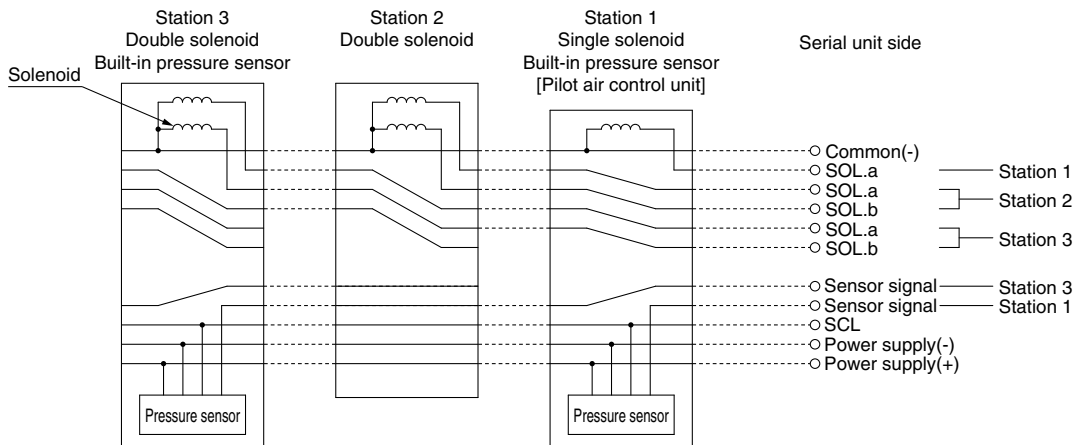

■ Single solenoid valve is installed to all double wiring. (Manifold specification sheet is not necessary.)

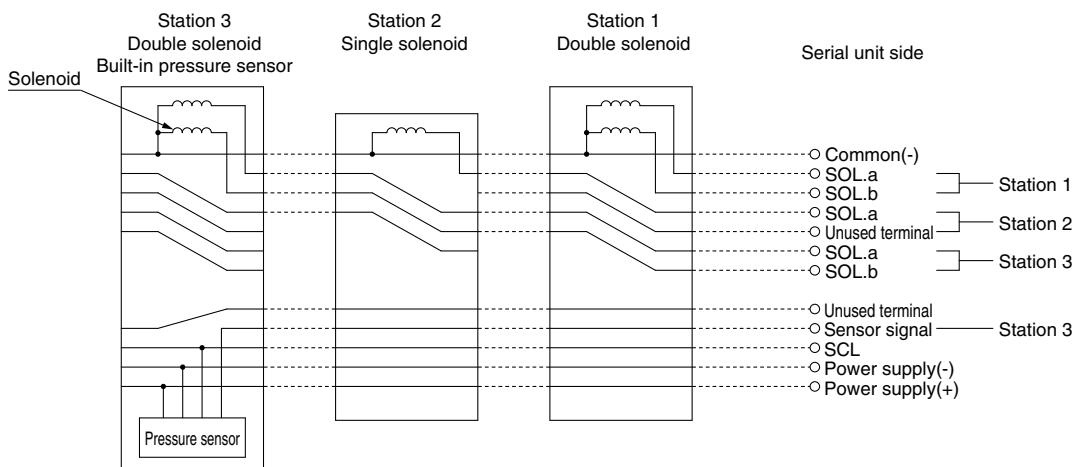

■ When single wiring and double wiring are mixed, and the pressure sensor layout is specified (Manifold specification sheet is necessary.)

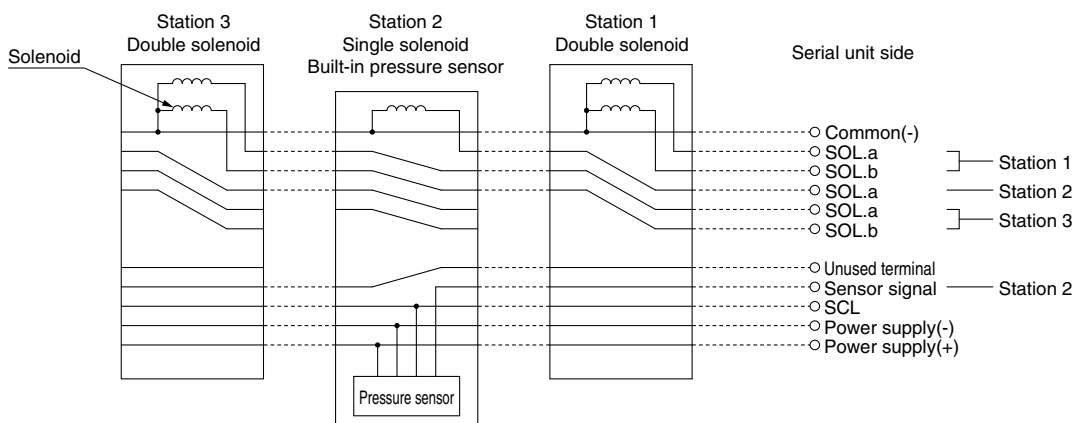

* These diagrams are for the purpose of explanation, and differ from the actual connector wiring.

JSY1000-E Series Spacer Type Ejector

Selectable With vacuum release flow adjustment unit

Selectable

High-noise reduction silencer

Spacer type ejector

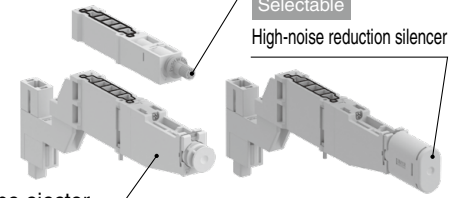

Ejector Specifications^{*1, *2}

Model	Standard supply pressure [MPa]	Nominal nozzle size [mm]	Supply pressure range [MPa]	Achievable vacuum pressure [kPa]	Max. suction flow [L/min (ANR)]	Air consumption [L/min (ANR)]	Noise level ^{*3, *4} [dB (A)]	
				Type S	Type S		Silencer exhaust type	High-noise reduction silencer exhaust type
JSY11M-EP-□A-07S□	0.45	0.7	0.1 to 0.6	-90	11.5	27	68	58
JSY11M-EP-□A-10S□		1.0			21			

*1 The values indicating characteristics are representative values and may vary depending on the atmospheric pressure (weather, altitude, etc.).

*2 Value at supply pressure.

*3 Actual values under SMC's measurement conditions (Not guaranteed values)

*4 This is a value obtained with a single ejector performing vacuum suction in the silencer air discharge system.

Max. Number of Manifold Stations that Can Operate Simultaneously [units]

Model	Max. number of manifold stations that can operate simultaneously [units] ^{*1, *2, *3}	
	U or D side Air supply to one side	U and D side Air supply to both sides
JSY11M-EP-□A-07S□	8	12
JSY11M-EP-□A-10S□	2	4

*1 Value at supply pressure.

*2 Actual values under SMC's measurement conditions (Not guaranteed values)

*3 This is the maximum number of stations that can simultaneously operate when vacuum is simultaneously generated by the ejectors only (excluding the solenoid valve for actuator).

When a solenoid valve for actuator and a spacer type ejector are mounted on the same manifold, simultaneously operating them may affect each other and degrade their performances.

As a countermeasure against this problem, by using a single SUP spacer (mountable only on the solenoid valve for actuator) and a SUP blocking disk, separate air supply to those components (refer to page 35).

Weight

Spacer type Ejector model	Exhaust type	Vacuum break flow adjusting unit	Weight [g]
JSY11M-EP-□A-□S	Silencer exhaust	Without	16
JSY11M-EP-□A-□SC6	ø6 One-touch fitting		20
JSY11M-EP-□A-□SH	High-noise reduction silencer exhaust		18
JSY11M-EP-□A-□S-N	Silencer exhaust	With	23
JSY11M-EP-□A-□SC6-N	ø6 One-touch fitting		27
JSY11M-EP-□A-□SH-N	High-noise reduction silencer exhaust		25

Supply Valve/Release Valve Flow Rate Characteristics

Valve model	Port size		Valve flow rate characteristics		
	1, 3/5 (P, E)	4, 2 (A, B)	Passage	C [dm ³ /(s·bar)]	b
JSY1100 JSY1200	C8	C6	1 → 4/2 (P → A/B)	0.96	0.30
			4/2 → 3/5 (A/B → E)	0.91	0.48
JSY1300			1 → 4/2 (P → A/B)	0.64	0.37
			4/2 → 3/5 (A/B → E)	0.66	0.46
JSY1E00			1 → 4 (P → A)	0.57	0.31
			3 → 2 (E → B)	0.78	0.20
JSY1P00	1 → 4 (P → A)	0.57	0.31		
	1 → 2 (P → B)	0.15	0.49		

Exhaust Characteristics/Flow Rate Characteristics

(Exhaust characteristics: Supply pressure 0.45 MPa)

JSY11M-EP-□A-07S□-□

Nominal Nozzle Size $\phi 0.7$ Specification: Exhaust Characteristics

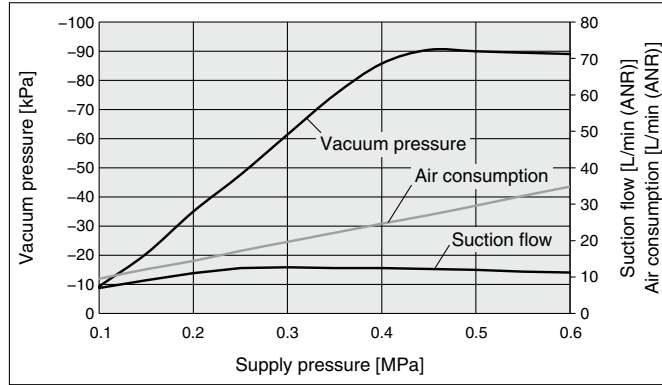

Nominal Nozzle Size $\phi 0.7$ Specification: Flow Rate Characteristics

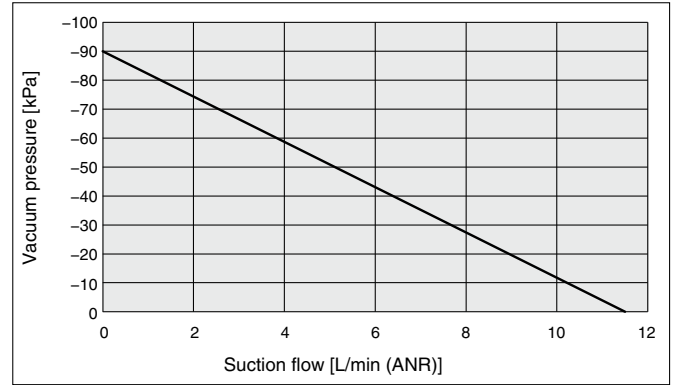

JSY11M-EP-□A-10S□-□

Nominal Nozzle Size $\phi 1.0$ Specification: Exhaust Characteristics

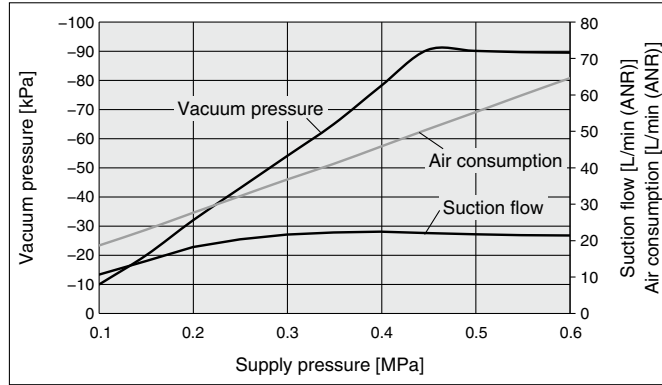

Nominal Nozzle Size $\phi 1.0$ Specification: Flow Rate Characteristics

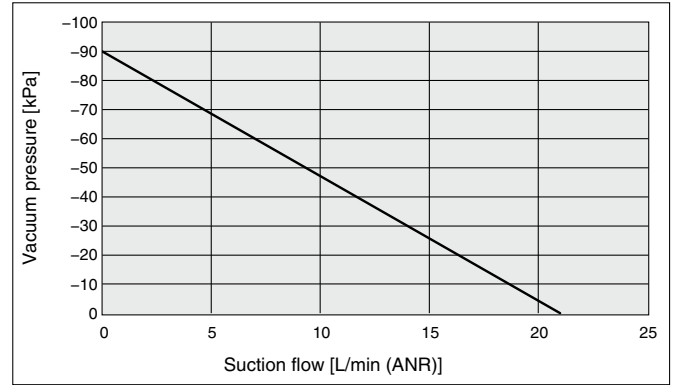

Release Flow Rate Characteristics

The graph when vacuum release flow adjusting needle is from fully closed to open in supply pressure 0.45 MPa.

Nominal Nozzle Size $\phi 0.7$ Specification

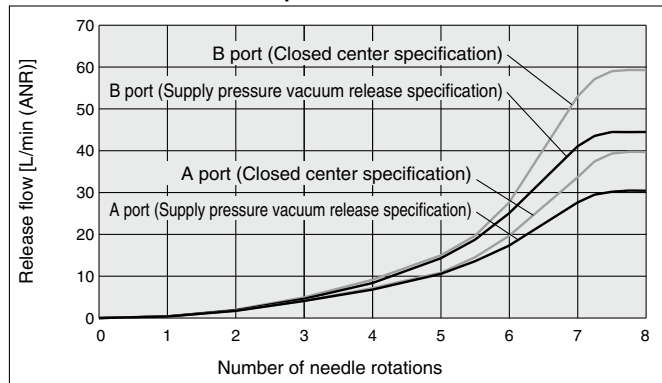

Nominal Nozzle Size $\phi 1.0$ Specification

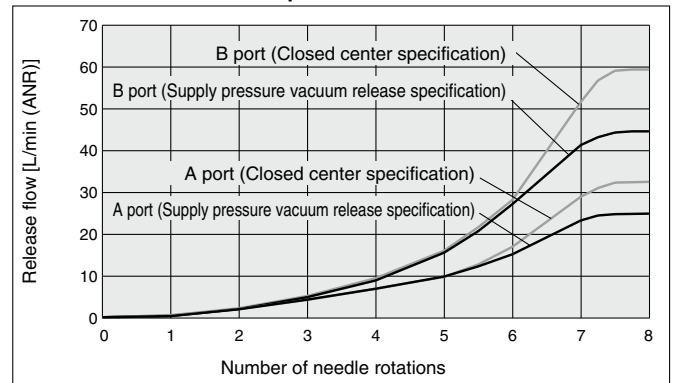

It is the vacuum release flow rate from one of the two vacuum port (A, B port). The other is turned plug.

Chart

Valve

Manifold

Spacer Type Ejector

Operation Diagrams

JSY1000-E

Manifold Exploded View

Fittings, Replacement Parts, Tools

Manifold Options

Made to Order

EX260

Specific Product Precautions

Construction

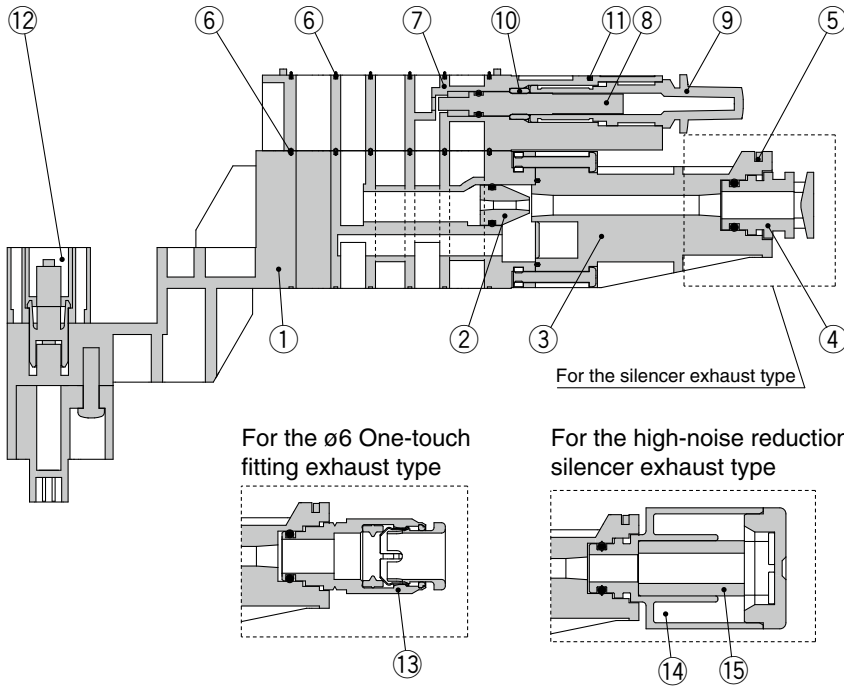

Component Parts

No.	Description	Material
1	Body	Resin
2	Nozzle	Resin
3	Diffuser	Resin
4	Silencer	Resin
5	Clip	Stainless steel
6	Base gasket	HNBR
7	Needle block	Resin
8	Needle	Resin
9	Knob	Resin
10	Needle guide	Brass
11	Lock pin	Stainless steel
12	Plug-in spacer	Resin
13	ø6 One-touch fitting	Stainless steel/Brass/ Resin/NBR/HNBR
14	High-noise reduction silencer	Resin
15	Sound absorbing material	Resin
—	O-ring	NBR/HNBR

Circuit Diagrams

JSY11M-EP-1A-□S□

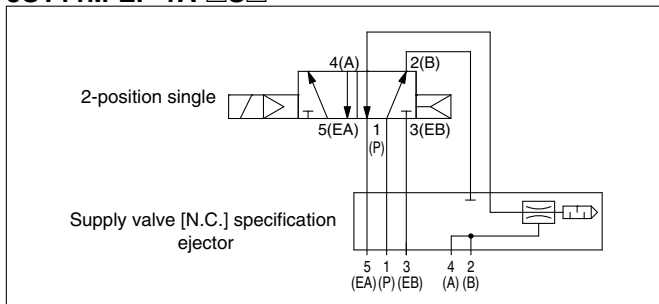

* The valves in the above circuit diagram are examples.

JSY11M-EP-2A-□S□

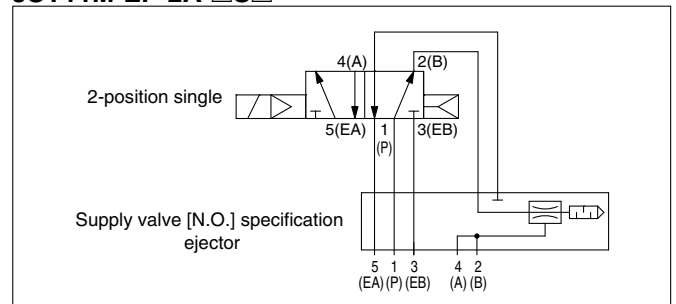

* The valves in the above circuit diagram are examples.

JSY11M-EP-3A-□S□-(N)

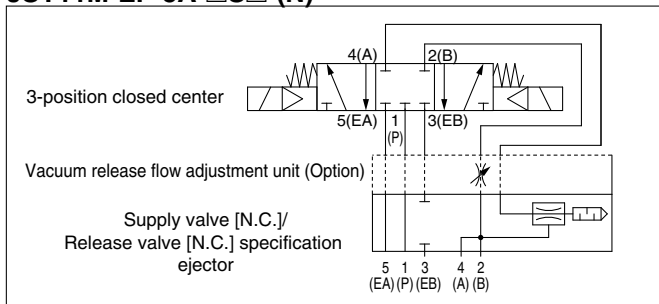

JSY11M-EP-3VA-□S□-(N)

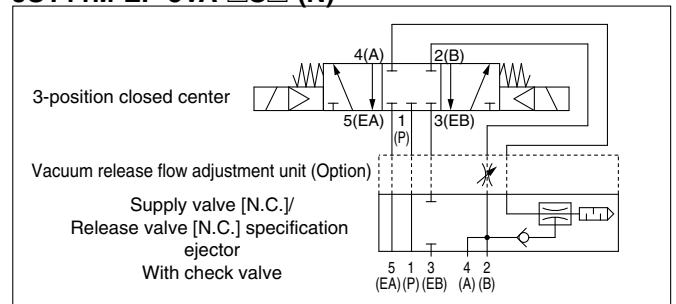

JSY11M-EP-4VA-□S□-(N)

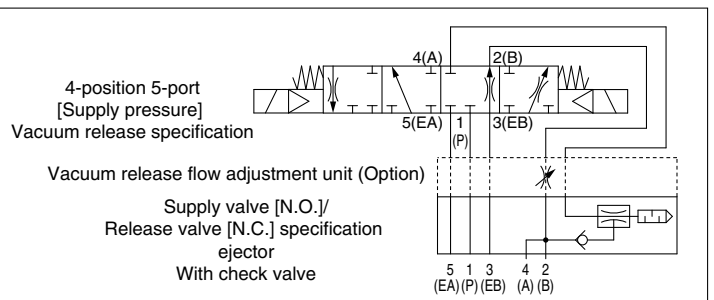
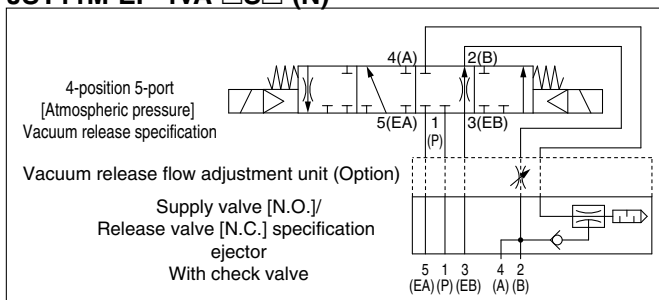

JSY1000-E Series

[Atmospheric Pressure] Vacuum Release Specification 4-Position 5-Port Valve/Spacer Type Ejector Operation Diagrams

Step	Pilot valve	Operation status	Description	Air circuit diagram
1	SOL.a: ON ↓ SOL.a: OFF	Vacuum generation	When electric power to the pilot valve A is turned ON in the standby state (B side is OFF) and then OFF, compressed air is supplied to the ① ejector and vacuum pressure is generated. As the generated vacuum pressure is supplied to the ② vacuum pad, the workpiece is suctioned, and it is possible to monitor the vacuum pad pressure value by means of the built-in ③ pressure sensor.	
2	SOL.a: ON	Vacuum holding (Energy saving)	After the workpiece is suctioned, when the vacuum pressure value in the ② vacuum pad exceeds the set threshold value, the control circuit of the SI Unit turns ON the power supply to the pilot valve A and stops the operation of the ① ejector. While the vacuum pressure in the ② vacuum pad is retained as the ④ check valve seals the pressure, if the vacuum pressure drops to the set threshold value due to air leakage from the ② vacuum pad or for other reason, the control circuit of the SI Unit turns OFF the power supply to the pilot valve A and the ① ejector generates the vacuum pressure again to retain the vacuum pressure necessary for suctioning. Repetition of the above actions can reduce wasteful air consumption. If the power supply is shut off due to power failure or for other reason, the power supply to the pilot valve A is turned OFF and the ejector generates vacuum pressure to prevent the workpiece from falling.	
3	SOL.b: ON	Vacuum release (Atmospheric pressure)	When the power supply to the pilot valve B is turned ON, atmospheric air (manifold exhaust port) is supplied to the ② vacuum pad to release the workpiece. Vacuum release by atmospheric pressure allows workpieces to be released without scattering.	
4	SOL.b: OFF	Vacuum release stop Atmospheric release (Standby)	After the workpiece is released, turning OFF the power supply to the pilot valve B stops vacuum release. As atmospheric pressure is supplied to the ② vacuum pad even in this state, in case where the workpiece is left suctioned because of insufficient vacuum release time or other reasons, it is possible to release the workpiece.	

[Supply Pressure] Vacuum Release Specification 4-Position 5-Port Valve/Spacer Type Ejector Operation Diagrams

Step	Pilot valve	Operation status	Description	Air circuit diagram
1	SOL.a: ON ↓ SOL.a: OFF	Vacuum generation	When electric power to the pilot valve A is turned ON in the standby state (B side is OFF) and then OFF, compressed air is supplied to the ① ejector and vacuum pressure is generated. As the generated vacuum pressure is supplied to the ② vacuum pad, the workpiece is suctioned, and it is possible to monitor the vacuum pad pressure value by means of the built-in ③ pressure sensor.	
2	SOL.a: ON	Vacuum holding (Energy saving)	After the workpiece is suctioned, when the vacuum pressure value in the ② vacuum pad exceeds the set threshold value, the control circuit of the SI Unit turns ON the power supply to the pilot valve A and stops the operation of the ① ejector. While the vacuum pressure in the ② vacuum pad is retained as the ④ check valve seals the pressure, if the vacuum pressure drops to the set threshold value due to air leakage from the ② vacuum pad or for other reason, the control circuit of the SI Unit turns OFF the power supply to the pilot valve A and the ① ejector generates the vacuum pressure again to retain the vacuum pressure necessary for suctioning. Repetition of the above actions can reduce wasteful air consumption. If the power supply is shut off due to power failure or for other reason, the power supply to the pilot valve A is turned OFF and the ejector generates vacuum pressure to prevent the workpiece from falling.	
3	SOL.b: ON	Vacuum release (Supply pressure)	When the power supply to the pilot valve B is turned ON, compressed air is supplied to the ② vacuum pad to release the workpiece. Narrowing the main valve opening through which vacuum release air passes (equivalent to $\phi 1.3$ orifice) restricts the flow rate and reduces the blow away of the workpiece. If the power supply is shut off due to power failure or for other reason, the power supply to the pilot valve B is turned OFF and the vacuum release air supply is stopped.	
4	SOL.b: OFF	Vacuum release stop Atmospheric release (Standby)	After the workpiece is released, turning OFF the power supply to the pilot valve B stops vacuum release. As atmospheric pressure is supplied to the ② vacuum pad even in this state, in case where the workpiece is left suctioned because of insufficient vacuum release time or other reasons, it is possible to release the workpiece.	

Chart

Valve

Manifold

Spacer Type Ejector

Operation Diagrams

JSY1000-E

Manifold Exploded View

Fittings, Replacement Parts, Tools

Manifold Options

Made to Order

EX260

Specific Product Precautions

Valve Manifold Integrated with Ejector System

Plug-in Connector Connecting Base EX260

Type 10
Side Ported

JSY1000-E Series



Internal Pilot

How to Order Manifolds

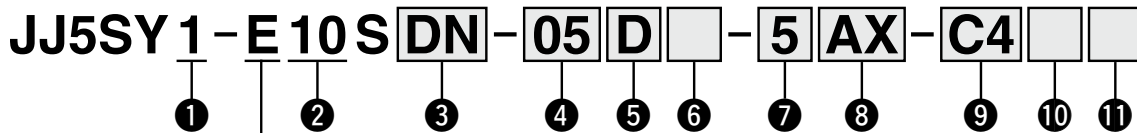

• Identification symbol for valve manifold integrated with ejector system

1 Series

1	JSY1000
---	---------

2 Type

10	Side ported
----	-------------

3 SI Unit

Symbol (Output polarity)	Protocol	Communication connector	Power supply connector
Negative common (PNP)			
0	Without SI Unit		
EN	EtherNet/IP™	M12: 2 pcs.	M12: 1 pc.
DN	EtherCAT	M8: 2 pcs.	M8: 2 pcs.
FN	PROFINET	M12: 2 pcs.	M12: 1 pc.
KN	IO-Link	M12: 1 pc.	

4 Valve stations

Symbol	Stations	Note
02	2 stations	Double wiring*1
⋮	⋮	
12	12 stations	
02	2 stations	Specified layout*2 (Up to 24 solenoids available)
⋮	⋮	
24	24 stations	

- *1 Double wiring: 2-position single, 2-position double, 3-position, and 4-position valves can be used on all manifold stations. However, the wiring of the pilot air control unit is single wiring. When a 2-position single valve is used with double wiring, there is an unused number of control signal. If this is not desired, order with a specified layout.
- *2 Specified layout: Indicate the wiring specifications on the manifold specification sheet. (Note that 2-position double, 3-position, and 4-position valves cannot be used where single wiring has been specified.)
- * This also includes the number of blanking plates.
- * The wiring of the pilot air control unit is single wiring specifications only.
- * For the maximum number of stations on which vacuum ejectors can operate simultaneously, refer to the ejector specifications on page 17.

5 P, E port entry

Symbol	P, E port entry
U	U side (2 to 10 stations)
D	D side (2 to 10 stations)
B	Both sides (2 to 24 stations)

6 SUP/EXH block assembly

Nil	Internal pilot
S	Internal pilot, Built-in silencer

- * The 3/5(E) port is plugged for the built-in silencer type.
- * When the built-in silencer type is used, keep the exhaust port from coming into direct contact with water or other liquids.
- * The external pilot specification should be ordered as Made to Order. For details, refer to page 37.

7 Number of pressure sensors

Symbol	Stations
1	1 station
⋮	⋮
5	5 stations

- * Select the sum number of stations of pilot air control block and block with built-in pressure sensor.

8 Pilot air control · block with built-in pressure sensor / pressure detection port

Symbol	Pressure detection port		
	Block with built-in pressure sensor		Pilot air control block
	A port (B port: Plug)	B port (A port: Plug)	X port
A	●	—	—
B*1	—	●	—
X*2	—	—	●
AX*2	●	—	●
BX*1, *2	—	●	●
M*3	Mixed specification		

- *1 With a 2-position 5-port valve, the A port flow rate decreases by approximately 9%.
- *2 Only one unit (first station) can be mounted on one manifold. For SUP/EXH block assembly specifications, select the internal pilot specifications. The wiring specification is single wiring only.
- *3 To specify position, select mixing specifications (symbol: M) and use Manifold Specifications Sheet.
- * The block incorporated with an A or B port pressure sensor is mounted at the a position closest to the U side. To specify its position, please specify it by means of the manifold specification sheet.
- * To specify the A and B port sensor specifications along with the pilot air control specifications, enter "AX" or "BX."

9 A, B port size (Metric/One-touch fitting)

Symbol	A, B port	Manifold pitch	
		Built-in pressure sensor	Without pressure sensor
C2	ø2 Straight*1	9 mm*1	6.5 mm
C4	ø4 Straight	9 mm	
C6	ø6 Straight		9 mm
CM	Straight port, mixed sizes*2	—	

- *1 The A/B port of a block incorporated with a pressure sensor is ø4 straight.
- *2 Indicate the sizes on the manifold specification sheet.

10 Mounting

Nil	Direct mounting
D	DIN rail mounting

11 DIN rail option*1

Symbol	DIN rail	Note
Nil	With	Only DIN rail mounting is available as the mounting method.
0	Without	
3	For 3 stations	Specify a length longer than that of the standard DIN rail. (The width of each additional station is equivalent to 9 mm pitch.)
⋮	⋮	
24	For 24 stations	

- *1 This can be only selected when the mounting method is DIN rail mounting.
- * If there is no SI Unit (S0), it is not possible to select a model with DIN rail (D and D3 to D24).

How to Order Valves (With mounting screw)

JSY1000 Series

JSY 1 2 0 0 [] T-5 NZ []

① ② ③ ④ ⑤ ⑥ ⑦

Base mounted • With power-saving circuit



① Series

1	JSY1000
---	---------

③ Pilot valve exhaust method

0	Pilot valve individual exhaust
---	--------------------------------

⑤ Rated voltage

5	24 VDC
---	--------

⑥ Light/surge voltage suppressor and common specification

Symbol	With light	Surge voltage suppressor	Common specification
NZ	●	●	Negative common

② Type of actuation

1	2-position	Single
2		Double
3	3-position	Closed center
4		Exhaust center
5		Pressure center
A	4-position dual 3-port	N.C./N.C.
B		N.O./N.O.
C		N.C./N.O.

④ Pilot type

Nil	Internal pilot
R	External pilot

* Select the external pilot specifications for a valve that is controlled by the pilot air control unit.

For other valves or when there is no pilot air control unit, select the internal pilot.

* External pilot specification is not applicable for 4-position dual 3-port valves.

⑦ Manual override

<p>Nil: Non-locking push type</p>	<p>D: Push-turn locking slotted type</p>
-----------------------------------	--

* **When ordering a valve individually, the base gasket is not included.**

Since the base gasket is attached to the manifold, please order the base gasket separately if it is needed for maintenance. Refer to page 30 for base gasket and mounting screw part numbers.

Pilot Air Control Unit

2-Position 3-Port Valve

JSY 1 1 0 T-5 NZ [] -B

① ② ③ ④ ⑤ ⑥ ⑦

With power-saving circuit • B port output



① Series

1	JSY1000 Base mounted
---	----------------------

④ Pilot type

Nil	Internal pilot
-----	----------------

⑥ Light/surge voltage suppressor and common specification

Symbol	With light	Surge voltage suppressor	Common specification
NZ	●	●	Negative common

② Type of actuation

1	N.C./Single solenoid
---	----------------------

③ Pilot valve exhaust method

0	Pilot valve individual exhaust
---	--------------------------------

⑤ Rated voltage

5	24 VDC
---	--------

⑦ Manual override

<p>Nil: Non-locking push type</p>	<p>D: Push-turn locking slotted type</p>
-----------------------------------	--

* **The 2-position 3-port valve is for the pilot air control unit.**

Be sure to use it by mounting it on a manifold block for pilot air control.

Chart

Valve

Manifold

Spacer Type Ejector

Operation Diagrams

JSY1000-E

Manifold Exploded View

Fittings, Replacement Parts, Tools

Manifold Options

Made to Order

EX260

Specific Product Precautions

JSY1000-E Series

How to Order Spacer Type Ejector (With mounting screw)

Spacer Type Ejector

JSY11M-EP-3VA-07SC6-N

① ② ③ ④ ⑤ ⑥

① Optional specifications

E	Spacer type ejector
---	---------------------

③ Nominal nozzle size

07	ø0.7
10	ø1.0

④ Achievable vacuum pressure

S	-90 kPa
---	---------

⑤ Exhaust type

Symbol	Exhaust type	
	Element	Element
Nil	Silencer	Without
H	High-noise reduction silencer	With
C6	ø6 One-touch fitting	—

② Body type and check valve for vacuum holding

Symbol	Body type	Check valve
1	Supply valve (N.C.)	Without
2	Supply valve (N.O.)	
3	Supply valve (N.C.)/Release valve (N.C.)	With
4V		

* For details on combinations of the ejector with energy saving function and supply valve/release valve, refer to the "Ejector Energy Saving Function Compatible Model and Combinations" section below.

⑥ Vacuum release flow adjustment unit

Nil	None
N	With (For body types "3," "3V," and "4V" * Types with a release valve only)

* When the JSY1000 series used for body type "4V" is the "JSY1P00," the release air is already restricted. However, select this option if further release air restriction is desired. In addition, note that for the "JSY1E00," the atmospheric pressure air for atmospheric pressure vacuum release is already restricted, which further reduces the vacuum release response speed.

Selectable With vacuum release flow adjustment unit

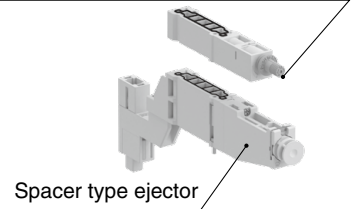

Selectable High-noise reduction silencer

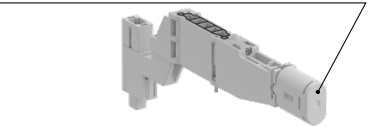

* Refer to "Ejector Specifications" on page 17 for the max. number of ejector stations that can operate simultaneously.

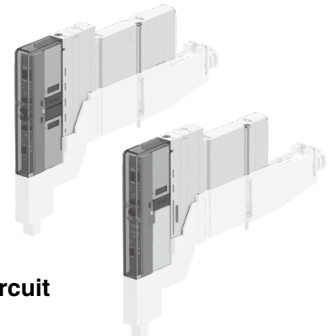

Ejector Supply Valve/Release Valve

JSY1000 Series

(Mounting of spacer type ejector is recommended)

JSY1P00T-5NZ

① ② ③ ④ ⑤ ⑥ ⑦

Base mounted With power-saving circuit

① Series

1	JSY1000
---	---------

④ Pilot type

Nil	Internal pilot
R	External pilot

* Select the external pilot specifications for a valve that is controlled by the pilot air control unit.

For other valves or when there is no pilot air control unit, select the internal pilot.

⑥ Light/surge voltage suppressor and common specification

Symbol	With light	Surge voltage suppressor	Common specification
NZ	●	●	Negative common

② Type of actuation

Symbol	Type of actuation	Applicable ejector body type symbol
1	2-position	Single
2		Double
3	3-position	Closed center
E	4-position 5-port	Atmospheric pressure vacuum release
P		Supply pressure vacuum release

* The 4-position 5-port valve is dedicated as a supply/release valve on the spacer type ejector. Therefore, do not use it for other usages.

* For details on combinations of the ejector with energy saving function and supply valve/release valve, refer to the "Ejector Energy Saving Function Compatible Model and Combinations" section below.

③ Pilot valve exhaust method

0	Pilot valve individual exhaust
---	--------------------------------

⑤ Rated voltage

5	24 VDC
---	--------

⑦ Manual override

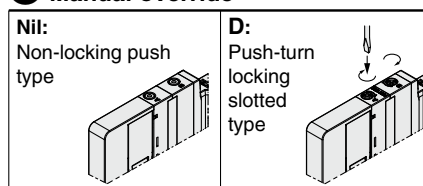

* When ordering a valve individually, the base gasket is not included.

Since the base gasket is attached to the ejector, please order the base gasket separately if it is needed for maintenance. Refer to page 30 for base gasket and mounting screw part numbers.

Ejector Energy Saving Function Compatible Model and Combinations

Supply valve specifications	N.C.		N.O.	
Vacuum release pressure specifications	Supply pressure		Atmospheric pressure	Supply pressure
Supply valve/release valve model	JSY1300T		JSY1E00T	JSY1P00T
Spacer type ejector model	JSY11M-EP-3VA-□□□□		JSY11M-EP-4VA-□□□□	
Manifold	Built-in pressure sensor			

How to Order Manifold Assembly

Example (JJ5SY1-E10SDN-□)

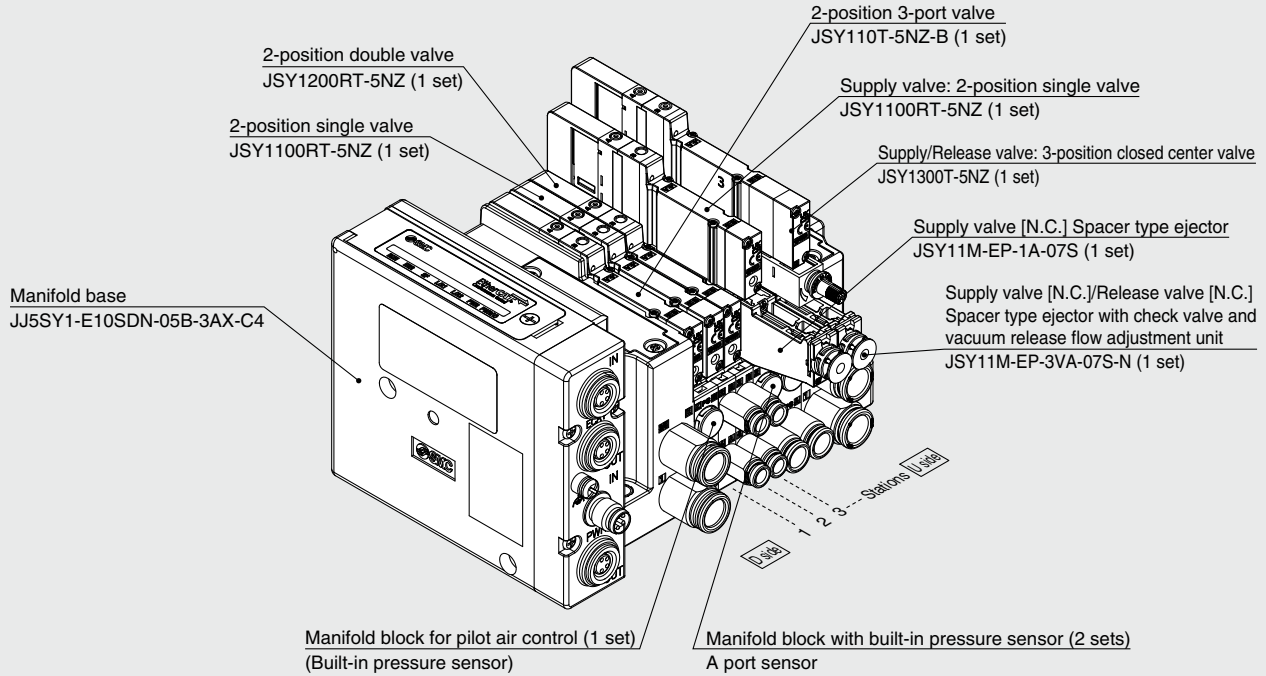

- JJ5SY1-E10SDN-05B-3AX-C4** 1 set (Type 10 5-station manifold base with 2 built-in pressure sensors and pilot air control unit part no.)
- * **JSY110T-5NZ-B** 1 set (2-position 3-port valve part no.)
 - * **JSY1100RT-5NZ** 1 set (2-position single valve part no.)
 - * **JSY1200RT-5NZ** 1 set (2-position double valve part no.)
 - * **JSY1100RT-5NZ** 1 set (Supply valve: 2-position single valve part no.)
 - * **JSY11M-EP-1A-07S** 1 set (Supply valve [N.C.] Spacer type ejector part no.)
 - * **JSY1300T-5NZ** 1 set (Supply/Release valve: 3-position closed center valve part no.)
 - * **JSY11M-EP-3VA-07S** 1 set (Supply valve [N.C.]/Release valve [N.C.] Spacer type ejector with check valve and vacuum release flow adjustment unit part no.)
- The asterisk denotes the symbol for the assembly.
 * Prefix the product number of the mounted valve or spacer type ejector with “*.”

- For the valve arrangement, the valves closest to the D side are considered the 1st stations respectively.
- Below the manifold part number, write down the valves and spacer type ejectors to be mounted in order from the first station as shown in the figure.
- Write down spacer type ejectors next to the valves they are to be combined with.
- If no layout is specified, the pilot air control block is mounted on the first station and the manifold block incorporated with a pressure sensor is mounted closest to the U side on the manifold.
- If the layout is complicated or you want to specify a desired layout, please specify it by means of the manifold specification sheet.
- On the manifold block for pilot air control, be sure to mount a 2-position 3-port valve to use it as a pilot air control unit.

Chart

Valve

Manifold

Spacer Type Ejector

Operation Diagrams

JSY1000-E

Manifold Exploded View

Fittings, Replacement Parts, Tools

Manifold Options

Made to Order

EX260

Specific Product Precautions

JSY1000-E Series

Type 10/Side Ported

Dimensions: JSY1000-E Series

Model integrated with ejector system

JJ5SY1-E10SDN- Stations $\frac{U}{D}$ - C2(C4)

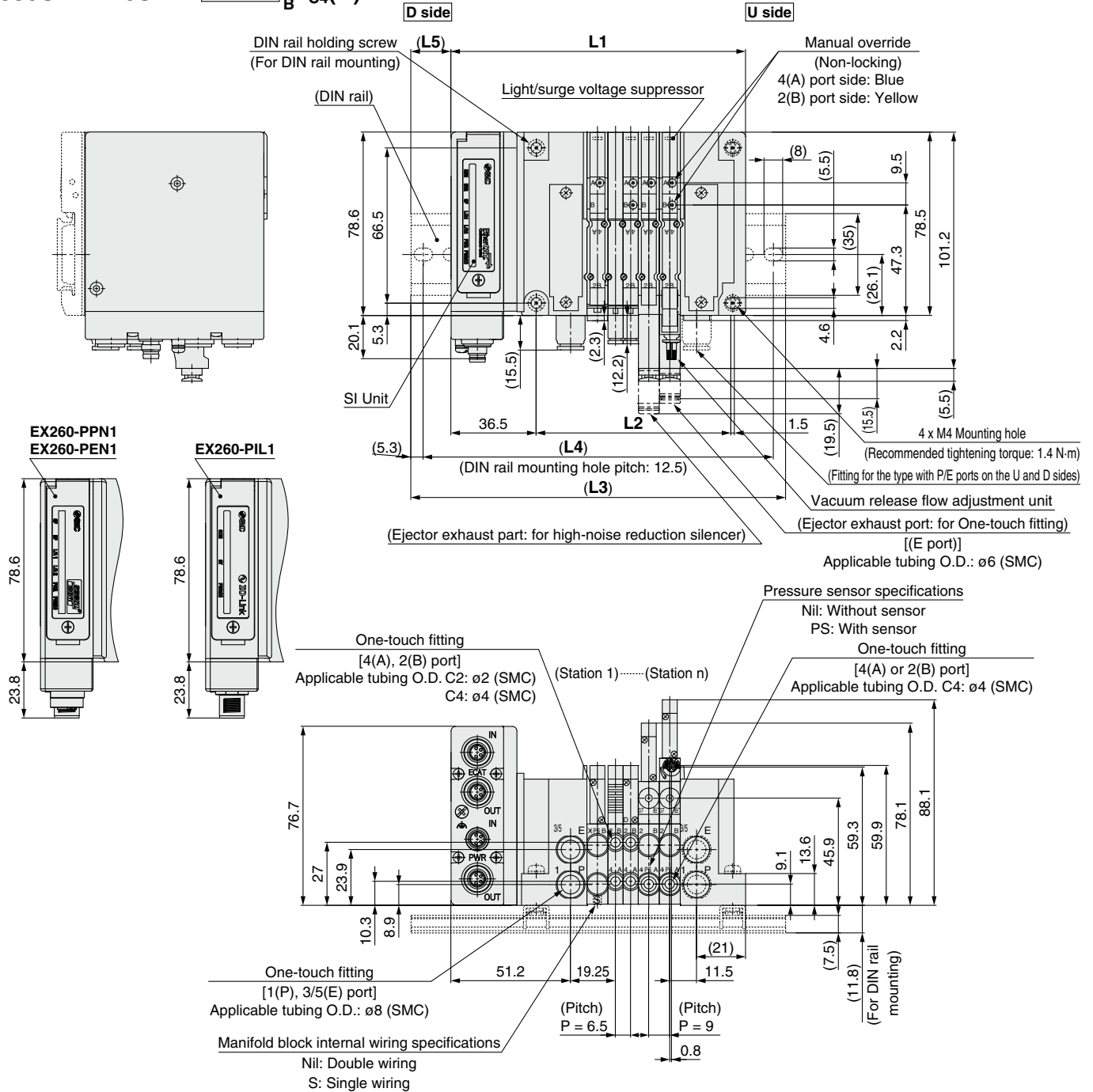

* These figures show the "JJ5SY1-E10SDN-05D-3AX-C4."
 * Refer to page 28 for dimensions of external pilot and built-in silencer.

$$L1 = 6.5 \times n1 + 9 \times n2 + 86.2$$

$$L2 = 6.5 \times n1 + 9 \times n2 + 43.4$$

$$M = L1 / 12.5 + 1 \quad \text{Decimal fractions are truncated.}$$

$$L3 = 12.5 \times M + 23$$

$$L4 = L3 - 10.5$$

$$L5 = (L3 - L1) / 2$$

n1: Number of 6.5 mm pitch manifold block stations (Without pressure sensor, Applicable fitting: $\phi 2$, $\phi 4$)
 n2: Number of 9 mm pitch manifold block stations (Built-in pressure sensor, Applicable fitting: $\phi 4$)

Type 10/Side Ported

Model integrated with ejector system

Dimensions: JSY1000-E Series

JJ5SY1-E10SDN- Stations $\frac{U}{D}$ - C6(D)

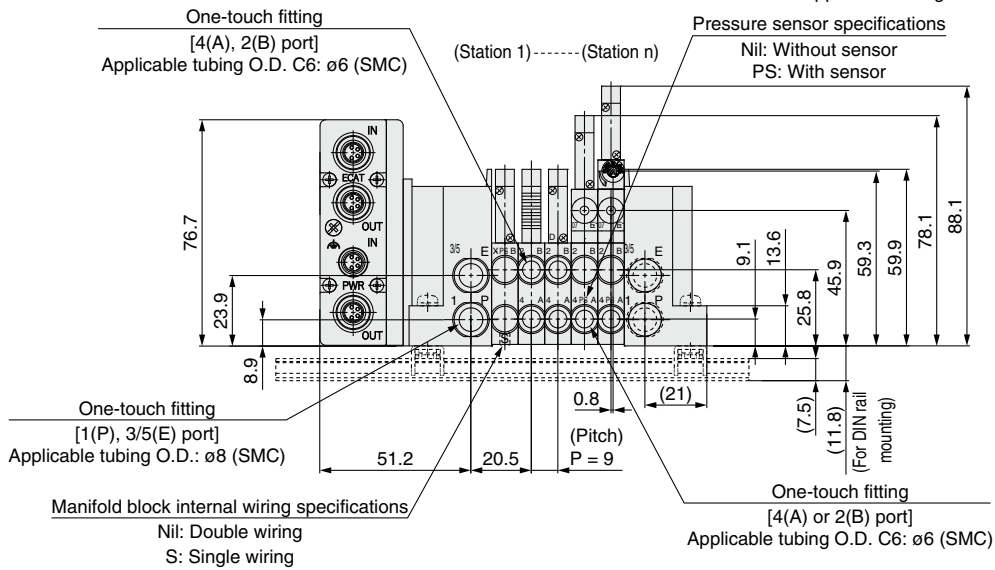
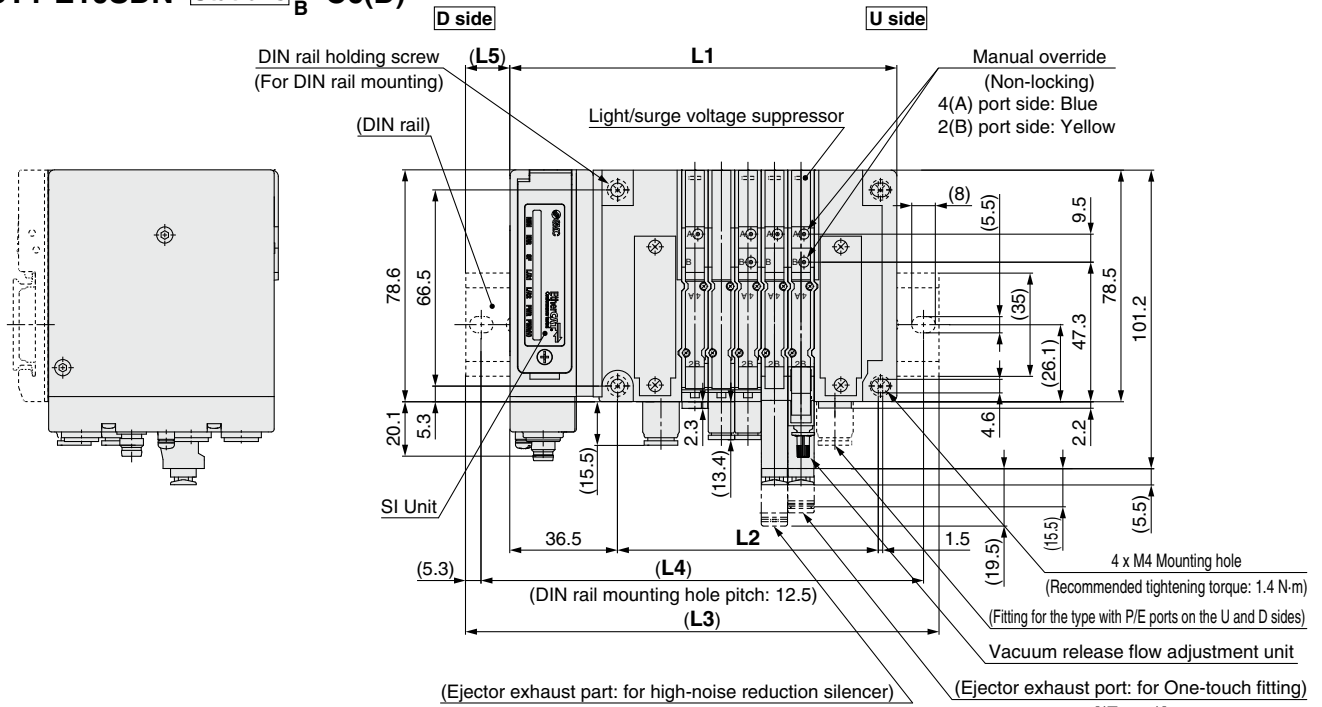

* These figures show the "JJ5SY1-E10SDN-05D-3AX-C6."
* Refer to page 28 for dimensions of external pilot and built-in silencer.

L: Dimensions

n: Stations

L \ n	2	3	4	5	6	7	8	9	10	11	12	13	14	15	16
L1	104.2	113.2	122.2	131.2	140.2	149.2	158.2	167.2	176.2	185.2	194.2	203.2	212.2	221.2	230.2
L2	61.4	70.4	79.4	88.4	97.4	106.4	115.4	124.4	133.4	142.4	151.4	160.4	169.4	178.4	187.4
L3	135.5	148	148	160.5	173	173	185.5	198	210.5	210.5	223	235.5	235.5	248	260.5
L4	125	137.5	137.5	150	162.5	162.5	175	187.5	200	200	212.5	225	225	237.5	250
L5	16	18	13	15	17	12	14	16	17	13	15	16	12	14	15

L \ n	17	18	19	20	21	22	23	24
L1	239.2	248.2	257.2	266.2	275.2	284.2	293.2	302.2
L2	196.4	205.4	214.4	223.4	232.4	241.4	250.4	259.4
L3	273	273	285.5	298	310.5	310.5	323	335.5
L4	262.5	262.5	275	287.5	300	300	312.5	325
L5	17	13	14	16	18	13	15	17

Chart

Valve

Manifold

Spacer Type Ejector

Operation Diagrams

JSY1000-E

Manifold Exploded View

Fittings, Replacement Parts, Tools

Manifold Options

Made to Order

EX260

Specific Product Precautions

JSY1000-E Series

Type 10/Side Ported

Dimensions: JSY1000-E Series

Model integrated with ejector system

JJ5SY1-E10SDN- $\frac{U}{B}$ -CM(D)

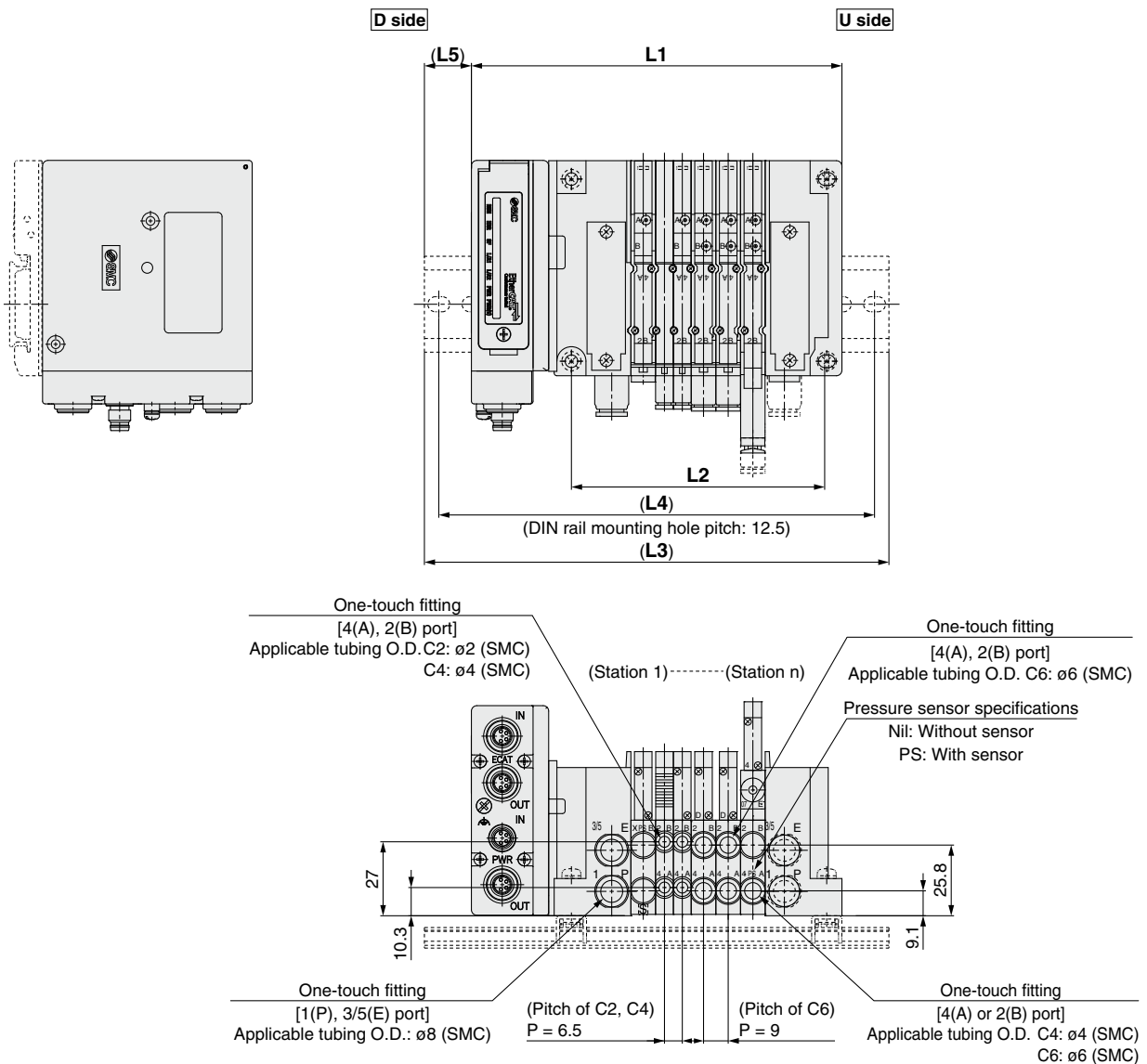

* These figures show the "JJ5SY1-E10SDN-05D-2AX-CM."
* Refer to page 28 for dimensions of external pilot and built-in silencer.

$$L1 = 6.5 \times n1 + 9 \times n2 + 86.2$$

$$L2 = 6.5 \times n1 + 9 \times n2 + 43.4$$

$$M = L1 / 12.5 + 1 \quad \text{Decimal fractions are truncated.}$$

$$L3 = 12.5 \times M + 23$$

$$L4 = L3 - 10.5$$

$$L5 = (L3 - L1) / 2$$

n1: Number of 6.5 mm pitch manifold block stations (Without pressure sensor, Applicable fitting: $\phi 2$, $\phi 4$)
n2: Number of 9 mm pitch manifold block stations (Built-in pressure sensor, Applicable fitting: $\phi 4$, $\phi 6$ /Without pressure sensor, Applicable fitting: $\phi 6$)

Type 10/Side Ported

External Pilot, Built-in Silencer

Dimensions: JSY1000-E Series

JJ5SY1-E10SDN - Stations $\frac{U}{D}(S,R) - \frac{C2}{C6}(D)$

External pilot (Made to Order)
 P, E port entry: D

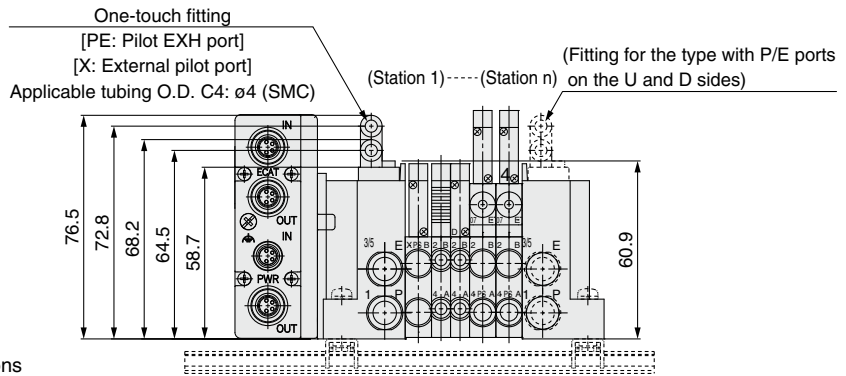
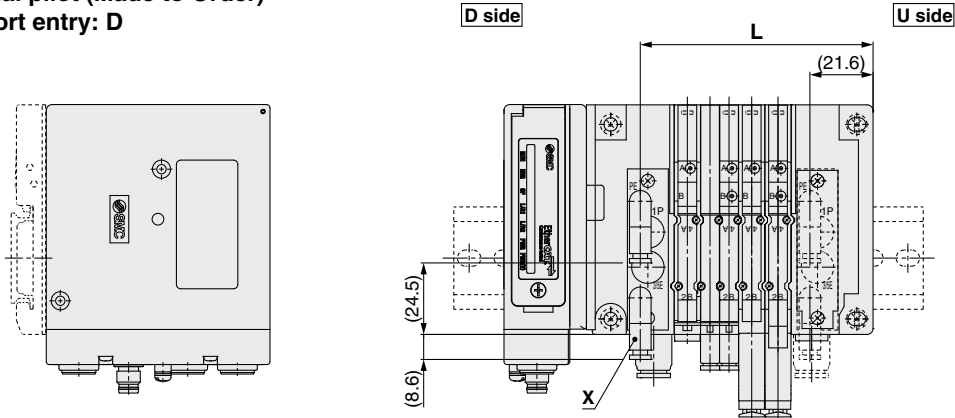

Calculation formula for L dimensions

$$L = 6.5 \times n1 + 9 \times n2 + 39.6$$

- n1: Number of 6.5 mm pitch manifold block stations (Without pressure sensor, Applicable fitting: ø2, ø4)
- n2: Number of 9 mm pitch manifold block stations (Built-in pressure sensor, Applicable fitting: ø4, ø6/Without pressure sensor, Applicable fitting: ø6)

* These figures show the "JJ5SY1-E10SDN-05DR-3AX-CM."

**Built-in silencer
 <Internal pilot>
 P, E port entry: D**

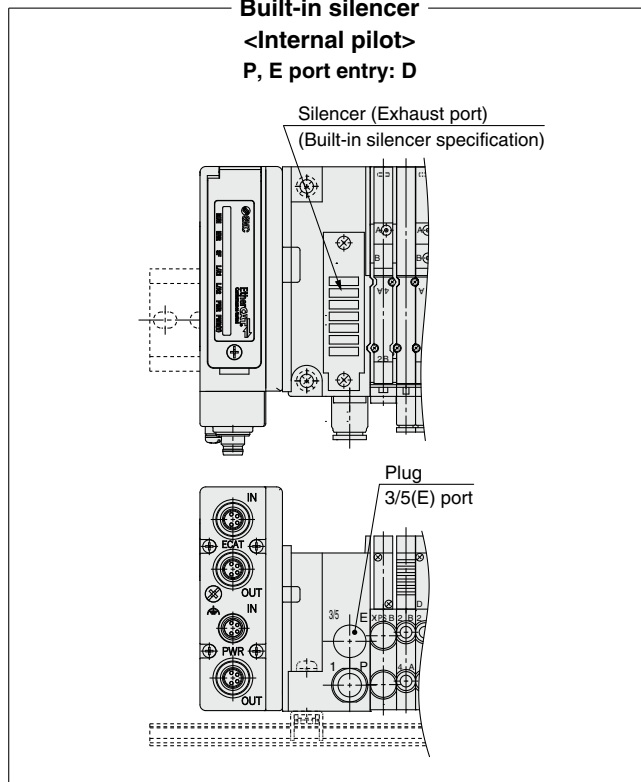

Chart

Valve

Manifold

Spacer Type
Ejector

Operation
Diagrams

JSY1000-E

Manifold
Exploded View

Fittings,
Replacement Parts,
Tools

Manifold
Options

Made to Order

EX260

Specific Product
Precautions

JSY1000-E Series Type 10 Manifold Exploded View

* Refer to page 30 for order numbers.

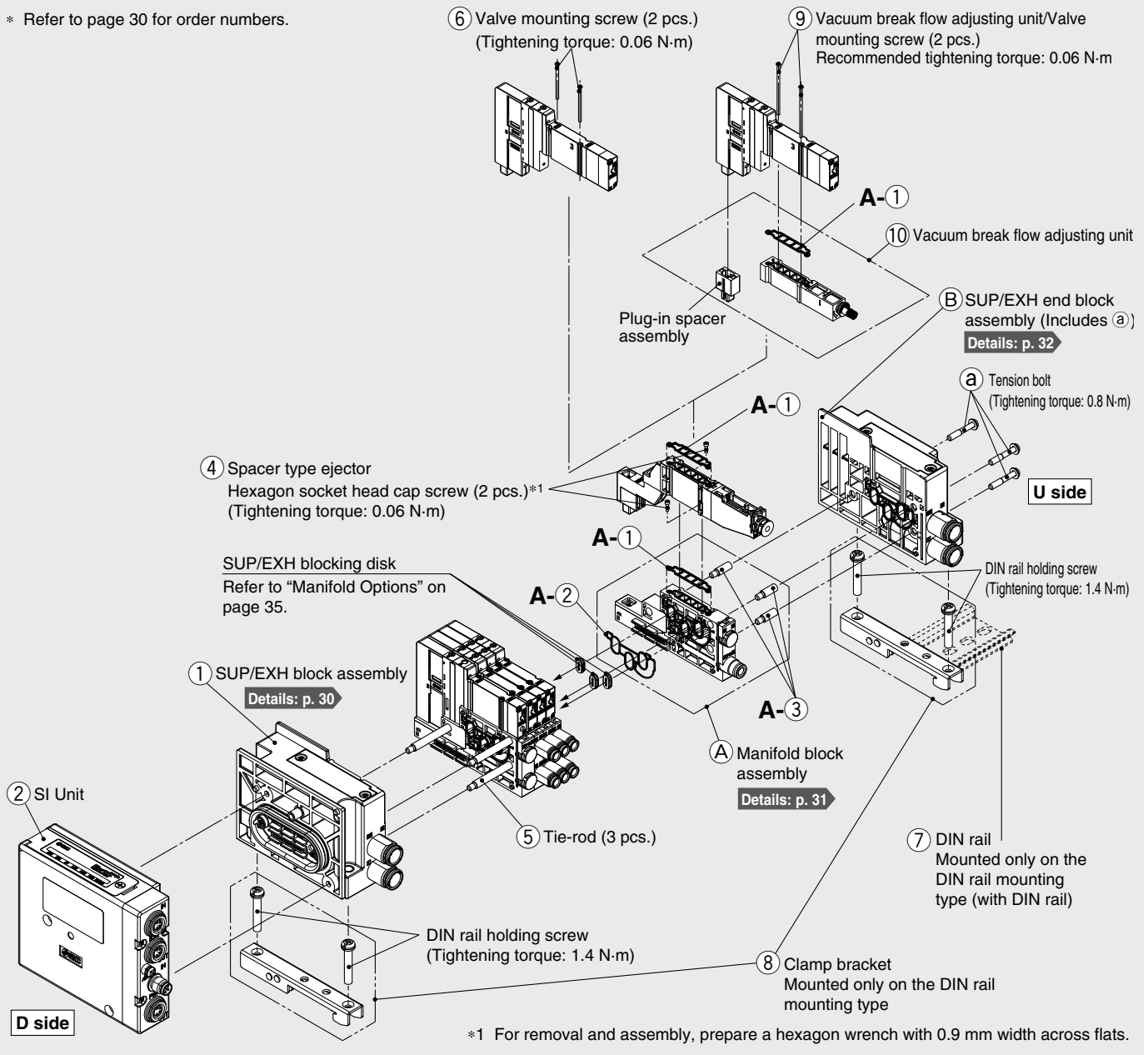

Type 10: How to Increase Connector Type Manifolds

1 Loosen the U-side tension bolt (a), and remove the (B) SUP/EXH end block assembly.

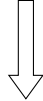

2 Screw in A-③ tie-rods for additional stations to the ⑤ tie-rod of the manifold.

(Screw them in until there is no gap between the tie-rods.)

3 Connect the (A) manifold block assembly to be added, and (B) SUP/EXH end block assembly and tighten the tension bolt (a).

Tightening torque for tension bolt (a) (M3): 0.8 N·m

⚠ Caution

1. Be sure to shut off the power and air supplies before disassembly. Furthermore, since air may remain inside the actuator, piping, and manifold, confirm that the air is completely exhausted before performing any work.
2. When disassembly and assembly are performed, air leakage may result if the tightening of the tension bolt is inadequate.

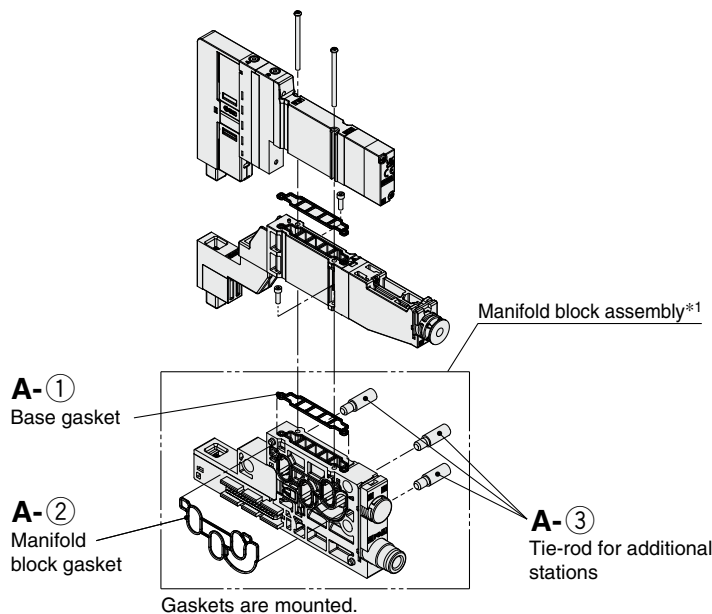

***1 Manifold block assembly**

No.	Description	Quantity	Note
A-①②	Gasket	1 pc. of each	For base and manifold block
A-③	Tie-rod for additional stations	3	

Refer to page 31 for ordering single unit.

Chart

Valve

Manifold

Spacer Type Ejector

Operation Diagrams

JSY1000-E

Manifold Exploded View

Fittings, Replacement Parts, Tools

Manifold Options

Made to Order

EX260

Specific Product Precautions

For the JJ5SY1-E10

No.	Description	JSY1000		Note	
		6.5 mm pitch	9 mm pitch		
A-①	Manifold block assembly	Base gasket (for connector connecting base)	JSY11M-9P-1A		Part numbers shown on the left are for 10 valves. (10 pcs.)
A-②		Manifold block gasket	JSY11M-9P-2		Supplied individually
A-③		Tie-rod for additional stations*1	JSY11M-49P-1-1-A (6.5 mm pitch)	JSY11M-49P-2-1-A (9 mm pitch)	3 pcs. supplied
④	Spacer type ejector mounting screw	Z2-SR1-A		10 pcs. (for 5 ejectors) Hexagon socket head cap screw (Width across flats: 0.9 mm)	
⑤	Tie-rod	JSY11M-49P-1-□-A (6.5 mm pitch)	JSY11M-49P-2-□-A (9 mm pitch)	□: Manifold stations (2 to 24 stations), 3 pcs. supplied	
⑥	Valve mounting screw	JSY11V-23-1A (M1.4 x 21.5)		Part numbers shown on the left are for 10 valves. (20 pcs.)	
⑦	DIN rail	VZ1000-11-1-□		Refer to page 34.	
⑧	Clamp bracket (for connector connecting base)	JSY11M-15P-1A		Supplied individually	
⑨	Valve/Unit mounting screw (M1.4 x 31.5)	JSY11V-23-2A		2 pcs. (1 unit).	
⑩	Vacuum release flow adjustment unit	Z2-NU1-A		Plug-in spacer assembly, ⑨mounting screw (2 pcs.) included	

*1 The manifold of the JSY1000 (JJ5SY1-E10) can be assembled by connecting the tie-rods for number of manifold stations.

Manifold Parts Nos.

① SUP/EXH block assembly **Dedicated to model integrated with ejector system**

JSY 1 1M-1P-15A □ - C8 □

Series

1	JSY1000
---	---------

Mounting

Nil	Direct mounting
D0	DIN rail mounting (Without DIN rail)

Pilot, Silencer type

Symbol	Pilot type		Built-in silencer
	Internal	External (Made to Order)	
Nil	●	—	—
S	●	—	●
R	—	●	—

* The 3/5(E) port is plugged for the built-in silencer type.

P, E port size (One-touch fittings)

Symbol	P, E port
C8	ø8 One-touch fitting
00*1	Plug

*1 Can be selected when the pilot, silencer type symbol is "Nil" or "S"
Not available for "R" type

⚠ Caution

As the SUP/EXH block and the manifold block for the valve manifold integrated with ejector system are dedicated components, do not combine them with other JSY1000 series product. Failure to follow this instruction may lead to a breakage. For the identification purpose, the substrate is colored in blue. As the substrates of other JSY1000 series products are colored in green, be sure to check the color before use.

As the SUP/EXH end block is not incorporated with any substrate, it can be used with other JSY1000 series products.

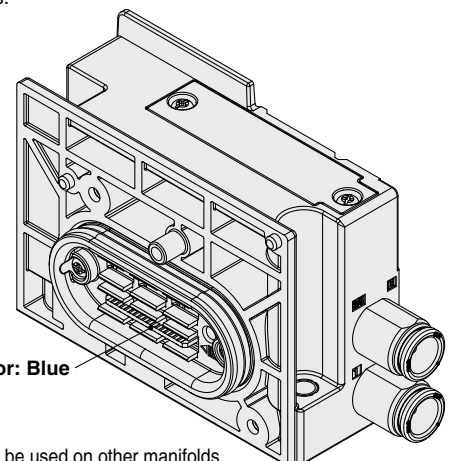

② EX260 SI Unit **Dedicated to model integrated with ejector system**

* Refer to page 38 for the part number and specifications.

⚠ Caution This product is dedicated for use with the valve manifold integrated with ejector system. It cannot be used on other manifolds.

⚠ Caution

- Be sure to shut off the power and air supplies before disassembly. Furthermore, since air may remain inside the actuator, piping and manifold, confirm that the air is completely exhausted before performing any work.
- When disassembly and assembly are performed, air leakage may result if the tightening of the cover and port block assemblies are inadequate.

JSY1000-E Series

Manifold Parts Nos.

Ⓐ Manifold block assembly Dedicated to model integrated with ejector system

JSY 1 1M-2P-4 D A- -C4

● **Series**

1	JSY1000
---	---------

● **Manifold block specifications**

Symbol	Pitch		Built-in pressure sensor
	6.5 mm	9 mm	
3	—	●	●
4	●	—	—
5	—	●	—

● **Wiring type**

S	Single wiring
D	Double wiring

● **Pressure sensor specifications**

Symbol	Pressure detection port	Applicable manifold block specification symbol
Nil	None	4, 5
1	A port	3 (Built-in pressure sensor)
2	B port (Option)*1	

*1 The flow rate at port A decreases by approximately 9%.
(When 2-position single/double solenoid valve is mounted)

● **A, B port size (One-touch fittings)**

Symbol	A, B port	Pitch	
		6.5 mm pitch	9 mm pitch
C2	ø2 One-touch fitting	●	—
C4	ø4 One-touch fitting	●	—
C6	ø6 One-touch fitting	—	●

⚠ Caution

As the SUP/EXH block and the manifold block for the valve manifold integrated with ejector system are dedicated components, do not combine them with other JSY1000 series product. Failure to follow this instruction may lead to a breakage. For the identification purpose, the substrate is colored in blue. As the substrates of other JSY1000 series products are colored in green, be sure to check the color before use. As the SUP/EXH end block is not incorporated with any substrate, it can be used with other JSY1000 series products.

Ⓐ Manifold (All parts inside ----- are included.) block assembly

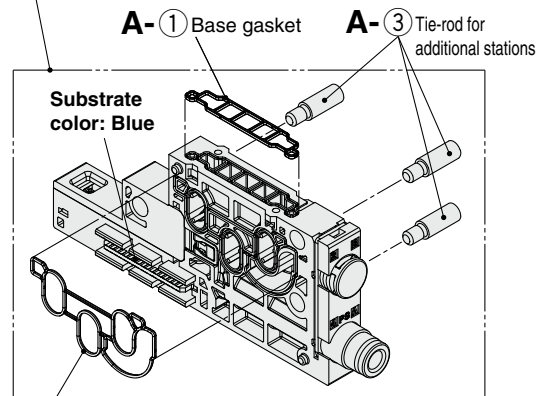

A-2 Manifold block gasket

Manifold block assembly accessories and the number of accessories

Accessories	Quantity
A-1 Base gasket	1 pc.
A-2 Manifold block gasket	1 pc.
A-3 Tie-rod for additional stations	3 pcs.

[For pilot air control] Manifold block assembly Dedicated to model integrated with ejector system

JSY 1 1M-2P-3 SA-3-00

● **Series**

1	JSY1000
---	---------

● **A, B port size**

Symbol	A, B port
00	Plug

● **Pressure sensor specifications**

Symbol	Pressure detection port
3	X port

● **Wiring type**

S	Single wiring
---	---------------

● **Manifold block specifications**

Symbol	Pitch		Built-in pressure sensor
	6.5 mm	9 mm	
3	—	●	●

* On a manifold block for pilot air control, be sure to mount a 2-position 3-port valve.

⚠ Caution

1. Be sure to shut off the power and air supplies before disassembly. Furthermore, since air may remain inside the actuator, piping and manifold, confirm that the air is completely exhausted before performing any work.
2. When disassembly and assembly are performed, air leakage may result if the tightening of the cover and port block assemblies are inadequate.

Manifold Parts Nos.

⑦ SUP/EXH end block assembly

JSY 1 1M-3P-1A [] - C8 []

● **Series**

1	JSY1000
---	---------

● **Mounting**

Nil	Direct mounting
D0	DIN rail mounting (Without DIN rail)

● **Pilot, Silencer type**

Symbol	Pilot type		Built-in silencer
	Internal	External (Made to Order)	
Nil	●	—	—
S	●	—	●
R	—	●	—

* The 3/5(E) port is plugged for the built-in silencer type.

● **P, E port size (One-touch fittings)**

Symbol	P, E port
C8	ø8 One-touch fitting
00*1	Plug

*1 Can be selected when the pilot, silencer type symbol is "Nil" or "S"
Not available for "R" type

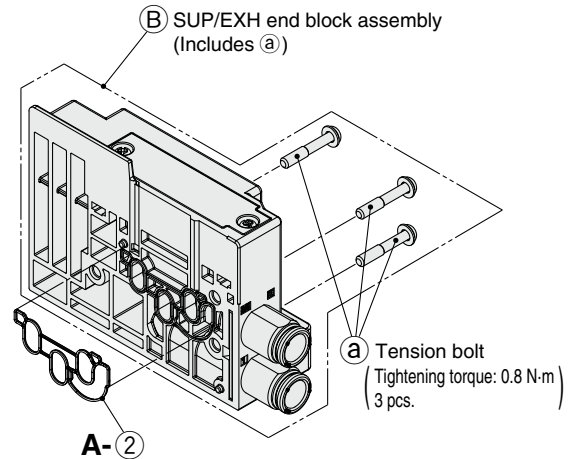

SUP/EXH end block assembly accessories and the number of accessories

Accessories	Quantity
a Tension bolt	3 pcs.
A-2 Manifold block gasket	1 pc.

* Gasket is mounted.

⑧ Clamp bracket

Series	Part no.
JSY1000	JSY11M-15P-1A

* The part number is for 1 piece.

⚠ Caution

As the SUP/EXH block and the manifold block for the valve manifold integrated with ejector system are dedicated components, do not combine them with other JSY1000 series product. Failure to follow this instruction may lead to a breakage. For the identification purpose, the substrate is colored in blue. As the substrates of other JSY1000 series products are colored in green, be sure to check the color before use. As the SUP/EXH end block is not incorporated with any substrate, it can be used with other JSY1000 series products.

■ Cover, Silencer cover, Port block for SUP/EXH (end) block assembly

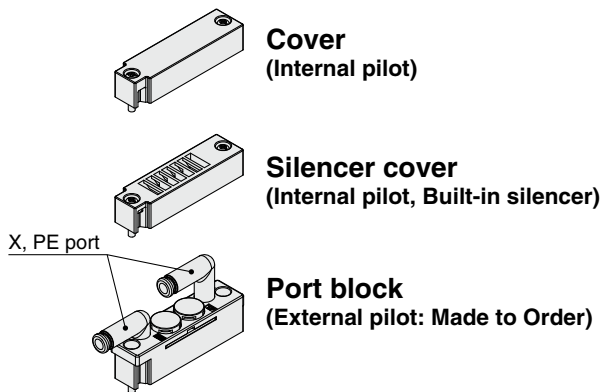

* Cover, silencer cover, and port block are included in the SUP/EXH (end) block assembly, but they need to be ordered for piping specification change.

* Mounting screws (2 pcs.) for SUP/EXH end block assembly are included.

**Tightening torque for mounting screw
JSY1000 (M2.5): 0.32 N·m**

JSY 1 1M-4P-1A

JSY 1 1M-5P-1A

JSY 1 1M-6P-1AR-00

● **Series**

1	JSY1000
---	---------

⚠ Caution

1. Be sure to shut off the power and air supplies before disassembly. Furthermore, since air may remain inside the actuator, piping and manifold, confirm that the air is completely exhausted before performing any work.
2. When disassembly and assembly are performed, air leakage may result if the tightening of the cover and port block assemblies are inadequate.

JSY1000-E Series

One-touch Fittings, Plug, Clip, Port Plate, Tube Releasing Tool

Refer to "How to Replace One-touch Fittings" on page 42 for the replacement method.

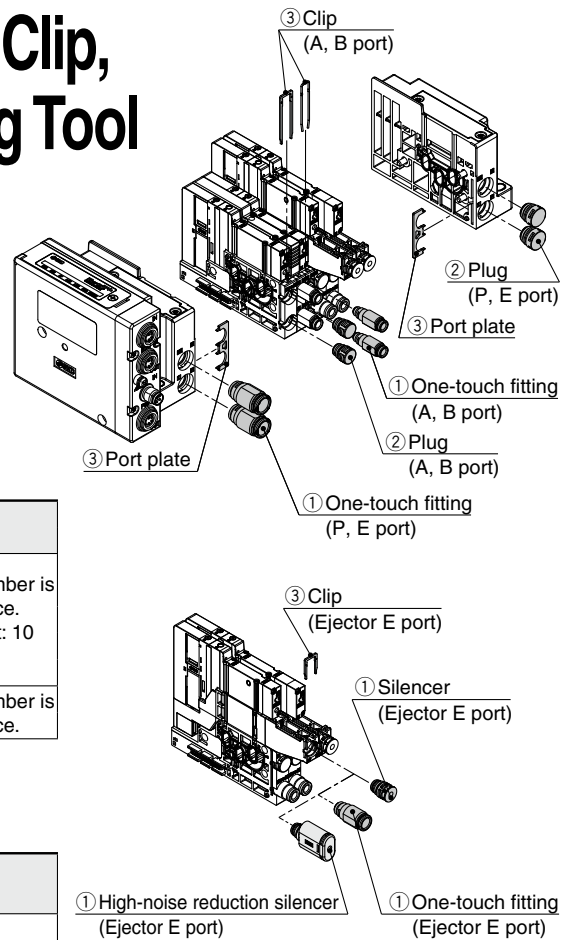

① One-touch Fittings and Silencer

Port size/Silencer	Series	JSY1000		Note
		6.5 mm pitch	9 mm pitch	
A, B port	ø2	KQSY10-C2	—	The part number is for 1 piece. (Sales unit: 10 pcs.)
	ø4	KQSY10-C4-X1336	KQSY11-C4	
	ø6	—	KQSY11-C6	
P, E port	ø8	KQSY30-C8		
Ejector E port	ø6	KQSY11-C6		
	Silencer	Z2-SC1-A		
High-noise reduction silencer	Z2-SC2-A			

* Refer to page 42 for assembling when a fitting is replaced.

② Plug

Piping port	Series	JSY1000	Note
P, E port		JSY11M-62P-1A	The part number is for 1 piece.
A, B port 9 mm pitch		JSY11M-62P-3A	

* As there is no plug for 6.5-mm pitch fitting for A and B ports, use the KQ2P series products.

③ Clip, Port Plate

Piping port	Series	JSY1000		Note
		For A, B port 6.5 mm pitch fittings	For A, B port 9 mm pitch fittings	
A, B port (Clip)		SJ1000-CL-1	JSY11M-19P-1A	The part number is for 10 pieces.
P, E port (Port plate)		JSY11M-10P-1		The part number is for 1 piece.
Ejector E port (Clip)		Z2-CL1-A		The part number is for 1 piece.

* Refer to page 42 for assembling when a fitting is replaced.

■ Tube Releasing Tool (This tool can be used to remove tubes from ports A and B.)

Series	For JSY1000	
Part no.	TG-0204	TG-0608
Applicable tubing O.D.	ø2/ø4	ø6

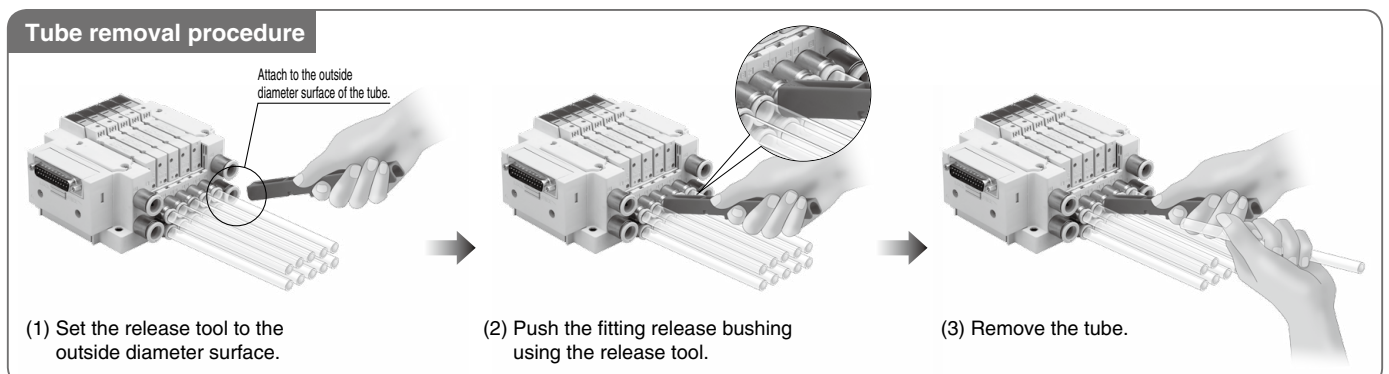

JSY1000-E Series Manifold Options

■ DIN rail dimensions/weight for the JSY1000 **Plug-in** connector connecting base

VZ1000-11-1-□

* After confirming the L3 dimension in the dimensions table of each series, refer to the DIN rail dimensions table below and specify the number in the box □.

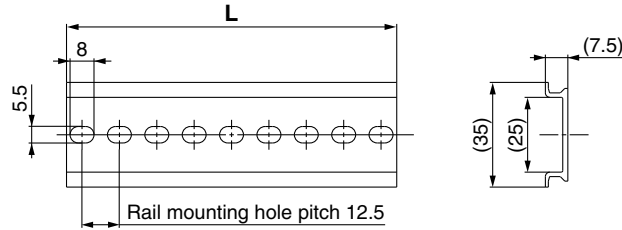

No.	0	1	2	3	4	5	6	7	8	9	10	11	12	13	14	15	16	17	18
L dimension	98	110.5	123	135.5	148	160.5	173	185.5	198	210.5	223	235.5	248	260.5	273	285.5	298	310.5	323
Weight [g]	17.6	19.9	22.1	24.4	26.6	28.9	31.1	33.4	35.6	37.9	40.1	42.4	44.6	46.9	49.1	51.4	53.6	55.9	58.1
No.	19	20	21	22	23	24	25	26	27	28	29	30	31	32	33	34	35	36	37
L dimension	335.5	348	360.5	373	385.5	398	410.5	423	435.5	448	460.5	473	485.5	498	510.5	523	535.5	548	560.5
Weight [g]	60.4	62.5	64.9	67.1	69.4	71.6	73.9	76.1	78.4	80.6	82.9	85.1	87.4	89.6	91.9	94.1	96.4	98.6	100.9
No.	38	39	40	41	42	43	44	45	46	47	48	49	50	51	52	53	54	55	56
L dimension	573	585.5	598	610.5	623	635.5	648	660.5	673	685.5	698	710.5	723	735.5	748	760.5	773	785.5	798
Weight [g]	103.1	105.4	107.6	109.9	112.1	114.4	116.6	118.9	121.1	123.4	125.6	127.9	130.1	132.4	134.6	136.9	139.1	141.4	143.6
No.	57	58	59	60	61	62	63	64	65	66	67	68	69	70	71				
L dimension	810.5	823	835.5	848	860.5	873	885.5	898	910.5	923	935.5	948	960.5	973	985.5				
Weight [g]	145.9	148.1	150.4	152.6	154.9	157.1	159.4	161.6	163.9	166.1	168.4	170.6	172.9	175.1	177.4				

⚠ Caution

Tightening torque for mounting screw
M1.4: 0.06 N·m

Manifold Options

* Refer to page 36 for dimensions.

■ Blanking plate

[With two mounting screws]

Used when valve additions are expected or for maintenance

JSY11M - 26P - 1A

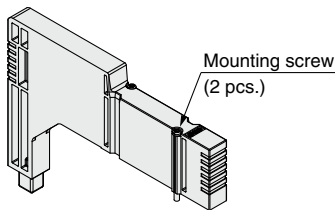

JSY11M-26P-1A

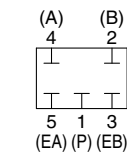

Circuit diagram

Chart

Valve

Manifold

Spacer Type
Ejector

Operation
Diagrams

JSY1000-E

Manifold
Exploded View

Fittings,
Replacement Parts,
Tools

Manifold
Options

Made to Order

EX260

Specific Product
Precautions

JSY1000-E Series

⚠ Caution

Tightening torque for mounting screw
M1.4: 0.06 N·m

Manifold Options

* Refer to page 36 for dimensions.

■ Individual SUP spacer

[With a plug-in spacer, a base gasket, and two mounting screws]
When the same manifold is to be used for different pressures, an individual SUP spacer assembly can be used to act as a supply port for different pressures.

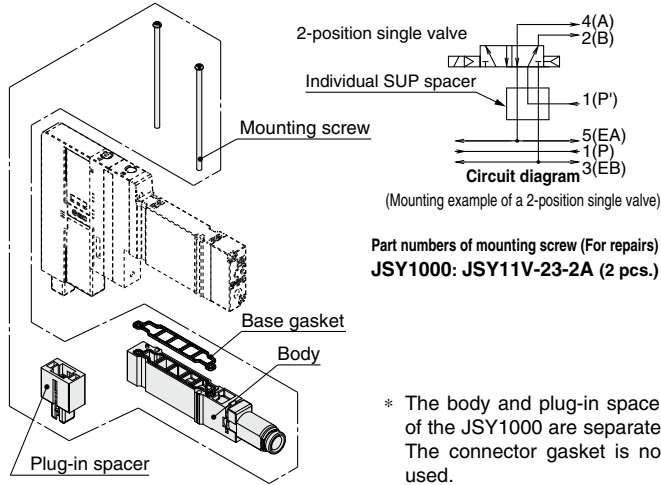

■ Individual EXH spacer

[With a plug-in spacer, a base gasket, and two mounting screws]
When valve exhaust affects other stations due to the circuit configuration, this spacer can be used for individual valve exhaust.

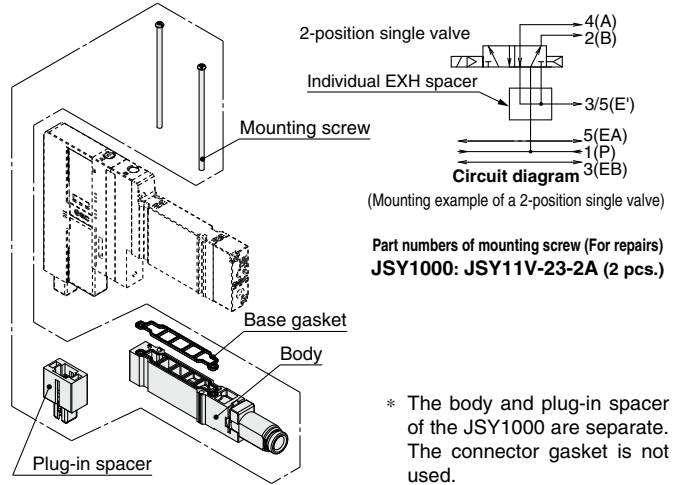

JSY 1 1M - 38 P - 1A - C4

Series

1 JSY1000

Spacer type

38 Individual SUP spacer
39 Individual EXH spacer

Port size (One-touch fitting)

Symbol	P, E port
C4	ø4 One-touch fitting

■ SUP/EXH blocking disk

[SUP blocking disk]

Inserting an SUP blocking disk in the pressure supply passage of a manifold valve can allow for the use of 2 different pressures (high and low) in 1 manifold.

[EXH blocking disk]

Inserting an EXH blocking disk in the exhaust passage of a manifold valve can separate the exhaust from the valve so it does not affect the other valves. It can also be used in positive pressure and vacuum pressure mixed manifolds. (2 pieces are required to block both the EA and EB sides of the EXH.)

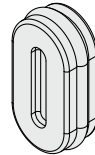

Series	SUP blocking disk	EXH blocking disk
JSY1000	JSY11M-40P-1A	JSY11M-40P-1A

■ Labels for blocking disks

These labels can be used to indicate and confirm where on the manifold the SUP/EXH blocking disk assemblies were inserted. (3 labels of each)

SUP/EXH blocking disk label

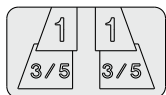

SUP blocking disk label

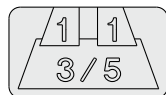

EXH blocking disk label

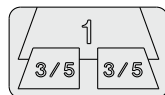

Series	Part no.
JSY1000	SJ3000-155-1A

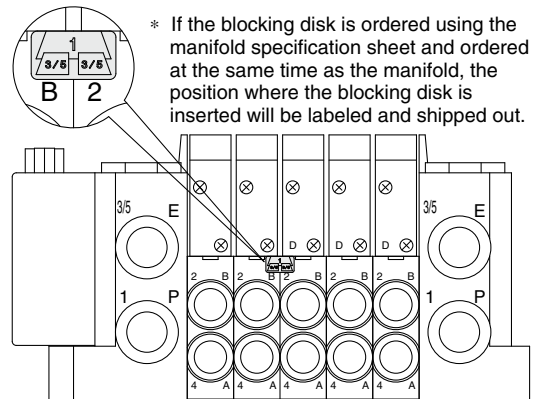

■ Silencer (One-touch fitting connection type)

This silencer can be mounted to the 3/5 (E: EXH) port of the manifold in one step.

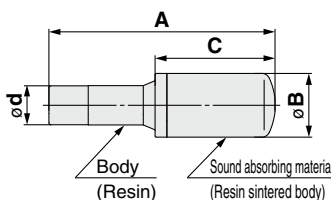

Series (ød)	Model	Effective area	A	B	C
For JSY1000 (ø8)	AN15-C08	20 mm ²	45	13	20

* Shipped together with the product

Dimensions: Manifold Options

■ Blanking plate

JSY1000 series

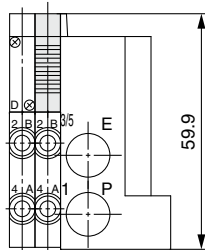
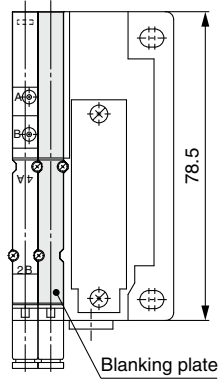

■ Individual SUP/EXH spacer

JSY1000 series

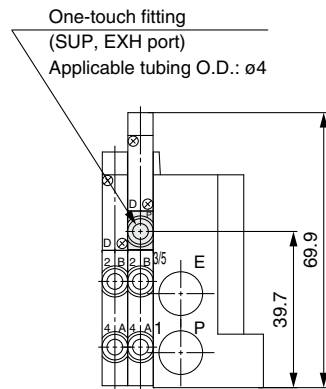
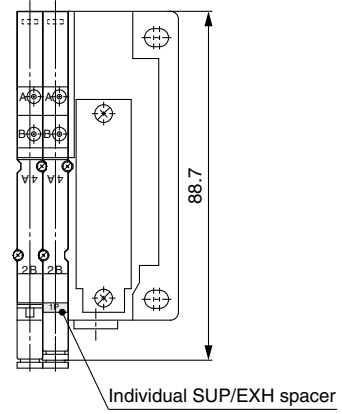

Chart

Valve

Manifold

Spacer Type
Ejector

Operation
Diagrams

JSY1000-E

Manifold
Exploded View

Fittings,
Replacement Parts,
Tools

Manifold
Options

Made to Order

EX260

Specific Product
Precautions

JSY1000-E Series

Made to Order

Please contact SMC for detailed dimensions, specifications, and delivery times.



1 External pilot

How to Order Manifolds

Refer to the How to Order manifolds.

JJ5SY1 - E10S - R - -

• SUP/EXH block assembly

R External pilot

* The combination of external pilot type "R" and silencer type "S" is not available.

How to Order Valves

JSY1 00 R T - 5

• Pilot type

R External pilot

- * External pilot specification is not applicable for 4-position dual 3-port valves and 2-position 3-port valves.
- * When "R" is selected for the pilot specification, select the external pilot type "R" for the manifold SUP/EXH block assembly specifications as well, or select a manifold with the pilot air control unit.

EX260 Series SI Unit/Pressure Sensor

How to Order SI Units

EX260 - P **EC1**

Model ●

Symbol	Protocol	Communication connector	Power supply connector	Manifold symbol	Applicable manifold
EN1	EtherNet/IP™	M12	M12	EN	JSY1000-E (Model integrated with ejector system)
EC1	EtherCAT	M8	M8	DN	
PN1	PROFINET	M12	M12	FN	
IL1	IO-Link	M12		KN	

SI Unit Specifications

Common Specifications

Power supply for control/sensor	Power supply voltage	24 VDC +20%, -15%
	Internal current consumption	100 mA or less
Power supply for solenoid valve	Power supply voltage	24 VDC +20%, -15%*1
Environmental resistance	Enclosure (Based on IEC 60529)	IP67*2
	Operating temperature range	-10 to +50°C
	Storage temperature range	-20 to +60°C
	Operating humidity range	35 to 85% RH (No condensation)
	Withstand voltage	500 VAC for 1 minute between external terminals and FE
	Insulation resistance	500 VDC, 10 MΩ or more between external terminals and FE
Standards	CE/UKCA marking, UL (CSA)	
Weight	200 g	
Input	Number of pressure sensors	Max. 5
	Connected load	Digital pressure sensor incorporated in manifold
Output	Number of outputs	Max. 24 outputs
	Connected load	Solenoid valve with surge voltage suppressor of 24 VDC and 0.5 W or less (manufactured by SMC)

*1 This is the SI Unit power supply voltage. Supply power according to the type of solenoid valve used.

*2 When connected with a JSY1000-E manifold, the rating will be IP40.

Specifications by Model

Model		EX260-PEC1
Applicable system	Protocol	EtherCAT*1
	Configuration file*2	ESI file
FoE	Yes	
CoE	Yes	
Communication speed	100 Mbps	
Communication connector specification	M8	
Accessories	Mounting screw	Hexagon socket head cap screw M3 x 30 (2 pcs.)
	Seal cap (for M8 connector socket)	EX9-AWES (2 pcs.)

*1 Use a CAT5 or higher communication cable for Ethernet/IP™, EtherCAT, and PROFINET.

*2 The configuration file can be downloaded from the SMC website: <https://www.smcworld.com>

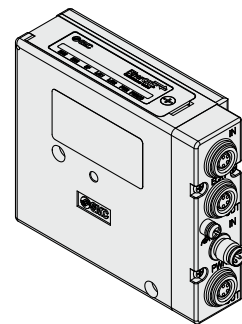

Chart

Valve

Manifold

Spacer Type Ejector

Operation Diagrams

JSY1000-E

Manifold Exploded View

Fittings, Replacement Parts, Tools

Manifold Options

Made to Order

EX260

Specific Product Precautions

EX260 Series SI Unit

Specifications by Model

Model		EX260-PPN1
Applicable system	Protocol	PROFINET*1
	Configuration file*2	GSD file
Fast Startup function		Yes
MRP function		Yes
MRPD function		Yes
Shared Device function		Yes
PROFenergy		Yes
System Redundancy S2 function		Yes
NET Load Class III		Yes
Communication speed		100 Mbps full duplex
Communication connector specification		M12
Accessories	Mounting screw	Hexagon socket head cap screw M3 x 30 (2 pcs.)
	Seal cap (for M12 connector socket)	EX9-AWTS (1 pc.)

Model		EX260-PIL1
Applicable system	Protocol	IO-Link
	Configuration file*2	IODD file
Version		1.1
IO-Link Port Class		Class B
Communication speed		COM2 (38.4 kbps)
Communication connector specification		M12
Accessories	Mounting screw	Hexagon socket head cap screw M3 x 30 (2 pcs.)

Model		EX260-PEN1
Applicable system	Protocol	EtherNet/IP™*1
	Configuration file*2	EDS file
Applicable functions		Quickconnect, DLR, Web server
Communication speed		100 Mbps
Communication connector specification		M12
Accessories	Mounting screw	Hexagon socket head cap screw M3 x 30 (2 pcs.)
	Seal cap (for M12 connector socket)	EX9-AWTS (1 pc.)

*1 Use a CAT5 or higher communication cable for Ethernet/IP™, EtherCAT, and PROFINET.

*2 The configuration file can be downloaded from the SMC website: <https://www.smcworld.com>

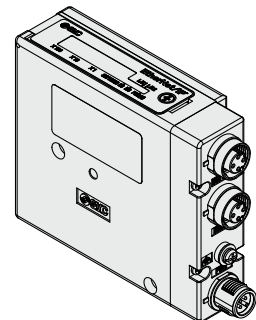
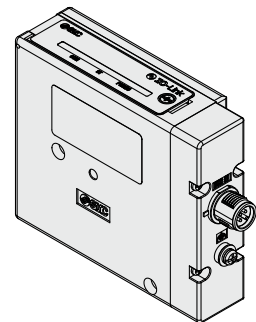
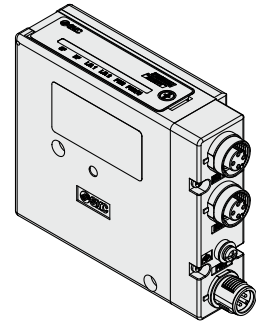

Pressure Sensor Specifications

Item	Specifications
Rated pressure range	-100 to 700 [kPa]
Withstand pressure	1.4 [MPa]
Accuracy	±1.5% F. S.

Accessory (Order separately)

Seal Cap (10 pcs.)

Be sure to mount a seal cap on any unused communication/power supply connectors. Otherwise, the specified enclosure cannot be maintained.



EX9-AWES
(For M8)



EX9-AWTS
(For M12)

Dimensions

M8 Communication/Power supply connector type

For EtherCAT

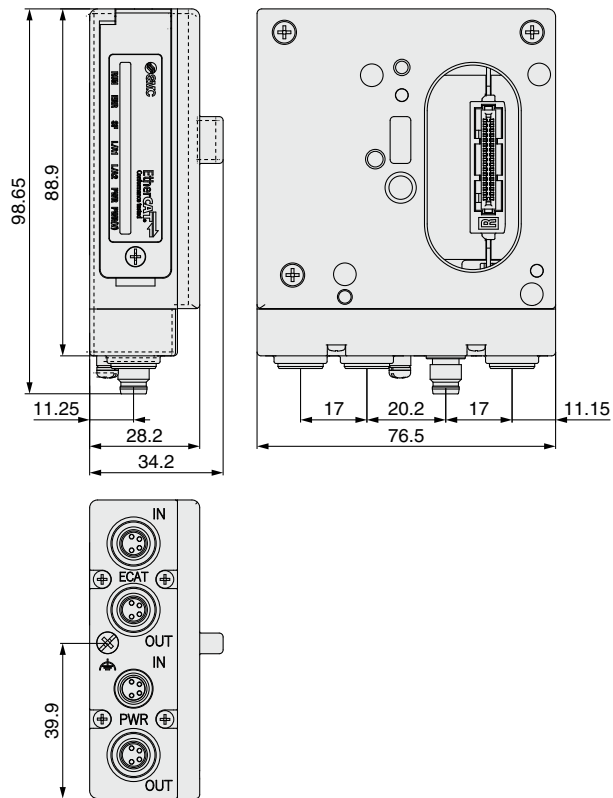

M12 Communication/Power supply connector type

For PROFINET

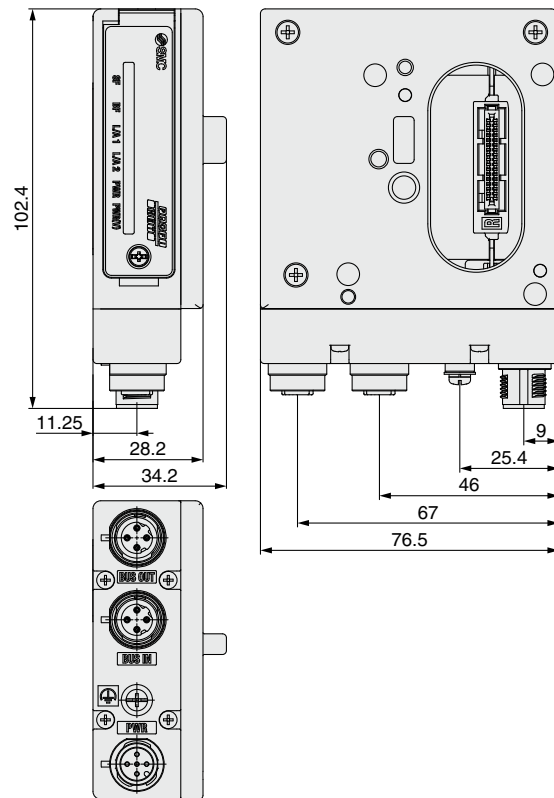

M12 communication connector type

For IO-Link

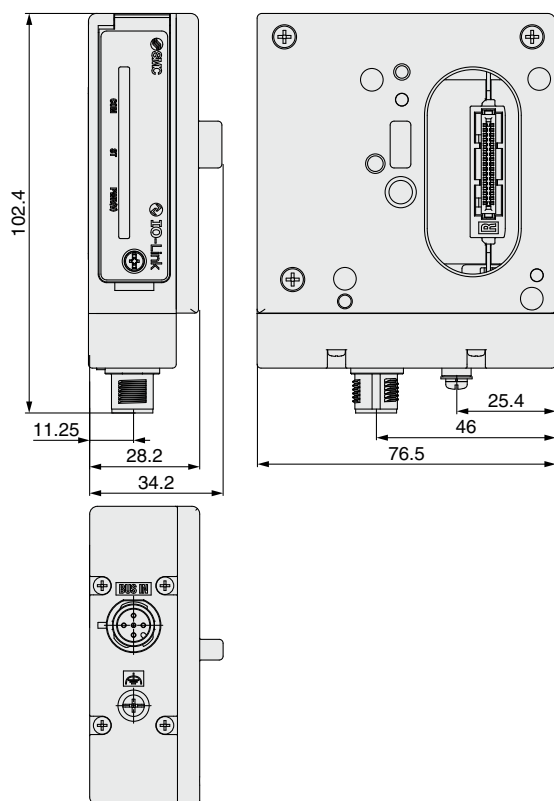

M12 communication connector type

For EtherNet/IP™

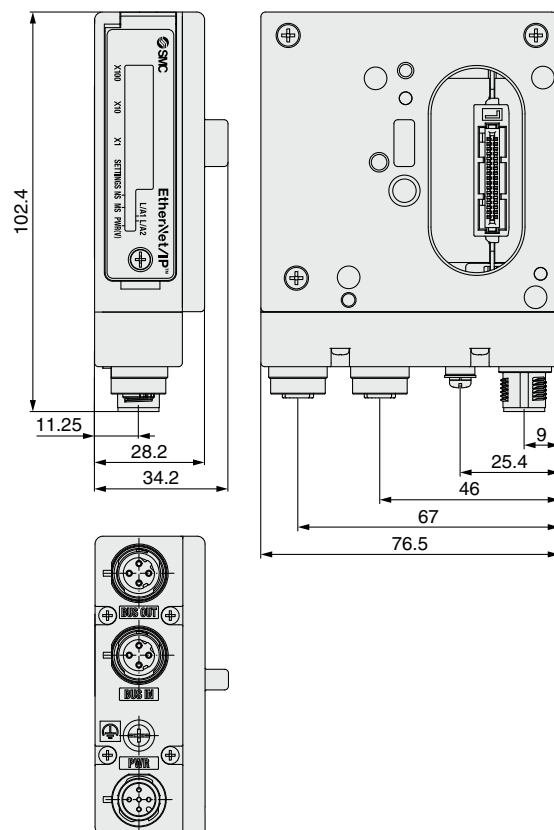

Parts Description

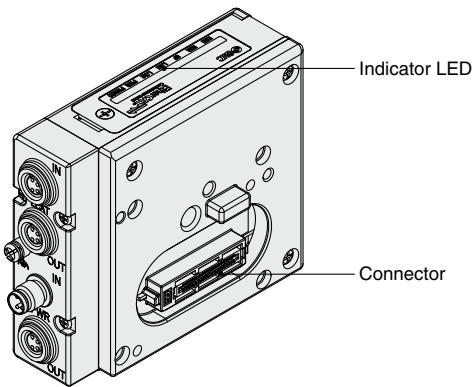

For EtherCAT

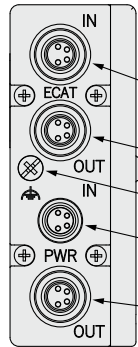

Part no.	EX260-PEC1
Protocol	EtherCAT
Communication connector (M8) Port 1	4 pins, socket, A code
Communication connector (M8) Port 2	4 pins, socket, A code
Ground terminal	M3
Power supply connector (M8) PWR IN	4 pins, plug, A code
Power supply connector (M8) PWR OUT	4 pins, socket, A code

For PROFINET

For EtherNet/IP™

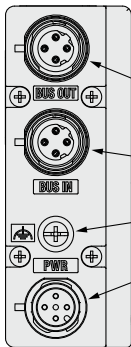

Part no.	EX260-PPN1, EX260-PEN1
Protocol	PROFINET, EtherNet/IP™
Communication connector (M12) Port 2	4 pins, socket, D code
Communication connector (M12) Port 1	4 pins, socket, D code
Ground terminal	M3
Power supply connector (M12) PWR	4 pins, plug, A code

For IO-Link

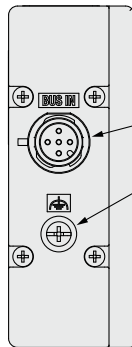

Part no.	EX260-PIL1
Protocol	IO-Link
Communication/Power supply connector (M12)	5 pins, plug, A code
Ground terminal	M3

* The communication line, control/sensor power supply line, and the valve power supply line are connected using the same cable.

LED Indicator

For EtherCAT EX260-PEC1

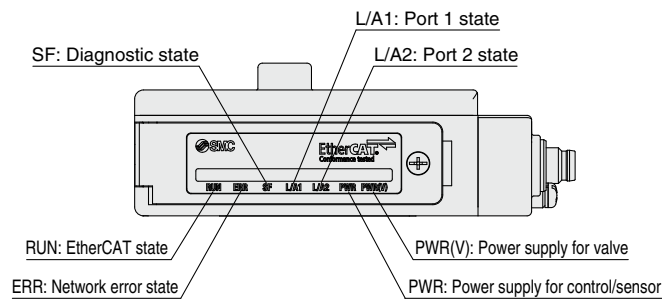

For EtherNet/IP™ EX260-PEN1

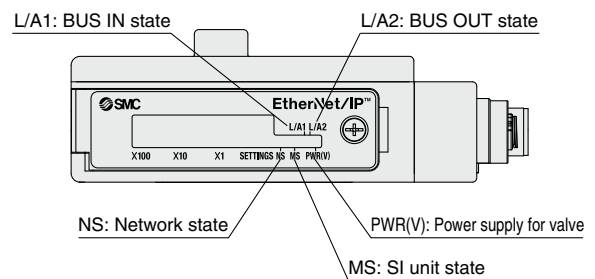

For PROFINET EX260-PPN1

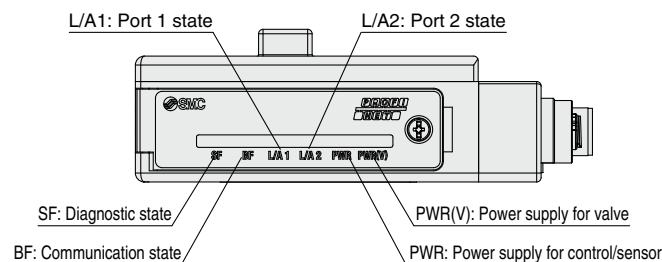

For IO-Link EX260-PIL1

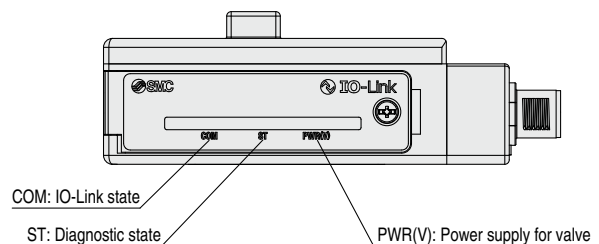

Communication Cable/Power Supply Cable

For details, refer to the [Web Catalog](#) (EX260 series).

* SMC does not provide cables for the EtherCAT compatible type (M8 connector). Order a cable from another cable manufacturer.

Chart
Valve
Manifold
Spacer Type Ejector
Operation Diagrams
JSY1000-E
Manifold Exploded View
Fittings, Replacement Parts, Tools
Manifold Options
Made to Order
EX260
Specific Product Precautions



JSY1000-E Series Specific Product Precautions 1

Be sure to read this before handling the products. Refer to the back cover for safety instructions. For 3/4-5-port solenoid valve and vacuum equipment precautions, refer to the "Handling Precautions for SMC Products" and the "Operation Manual" on the SMC website: <https://www.smcworld.com>

Environment

Warning

- Do not use valves in atmospheres of corrosive gases, chemicals, sea water, water, water vapor, or where there is direct contact with any of these.

Valve Mounting

Caution

Mount it so that there is no slippage or deformation in gaskets, and tighten with the tightening torque as shown on the right.

Series	Thread size	Tightening torque
JSY1000	M1.4	0.06 N·m

Manual Override

Warning

Without electric signals to the solenoid valve, the manual override is used for switching the main valve. Connected actuator is started by manual operation. Use the manual override after confirming that there is no danger.

Non-locking push type

Push down on the manual override button until it stops.

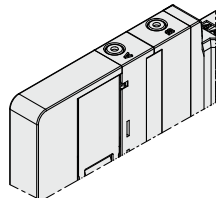

Push-turn locking slotted type [D type]

Push down on the manual override with a small flat head screwdriver until it stops, and then turn it 90° clockwise. The manual override is then locked. To release it, turn it counter-clockwise.

If it is not turned, it can be operated the same way as the non-locking push type.

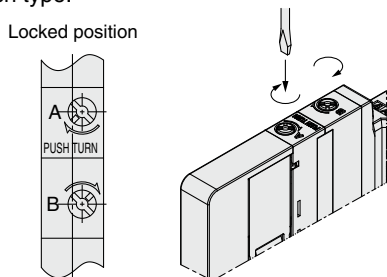

Caution

Do not apply excessive torque when turning the manual override. [0.1 N·m]

When locking the manual override, be sure to push it down before turning. Turning without first pushing it down can cause damage to the manual override and other trouble such as air leakage, etc.

Used as a 3-Port Valve

Caution

In case of using a 5-port valve as a 3-port valve

The JSY1000 series can be used as normally closed (N.C.) or normally open (N.O.) 3-port port valves by closing one of the cylinder ports 4(A) or 2(B) with a plug. However, they should be used with the exhaust ports kept open. Use them when a double solenoid type 3-port valve is required.

Plug position		B port	A port
Type of actuation		N.C.	N.O.
Number of solenoids	Single	(A)4 2(B) (EA)5 1 3(EB) (P)	(A)4 2(B) (EA)5 1 3(EB) (P)
	Double	(A)4 2(B) (EA)5 1 3(EB) (P)	(A)4 2(B) (EA)5 1 3(EB) (P)

Light/Surge Voltage Suppressor

Caution

With power-saving circuit

Power consumption is decreased to approx. 1/2.5 of the amount consumed at startup by reducing the wattage required to hold the valve in an energized state. (Effective energizing time is over 67 ms at 24 VDC.)

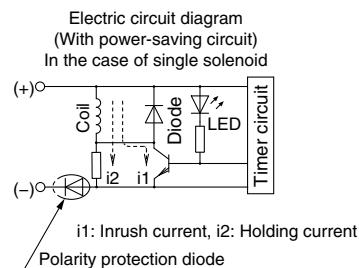

The circuit shown above reduces the power consumption for holding in order to save energy. Refer to the electrical power waveform as shown below.

<Electrical power waveform with power-saving circuit>

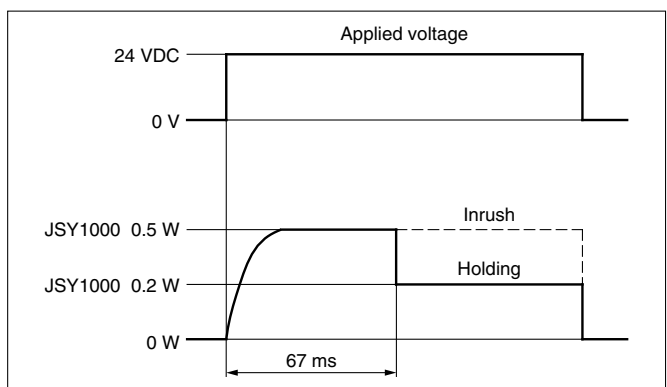

- Since the voltage will drop by approx. 0.5 V due to the transistor, pay attention to the allowable voltage fluctuation. (For details, refer to the solenoid specifications of each type of valve.)



JSY1000-E Series Specific Product Precautions 2

Be sure to read this before handling the products. Refer to the back cover for safety instructions. For 3/4/5-port solenoid valve and vacuum equipment precautions, refer to the "Handling Precautions for SMC Products" and the "Operation Manual" on the SMC website: <https://www.smcworld.com>

Light/Surge Voltage Suppressor

⚠ Caution

Residual voltage of the surge voltage suppressor

* If a diode surge voltage suppressor is used, there is some residual voltage to the protection element and rated voltage. Therefore, refer to the table below and pay attention to the surge voltage protection on the controller side.

Residual Voltage

Surge voltage suppressor	24 VDC
Z	Approx. 1 V

Energization of a 2-Position Double Solenoid Valve

⚠ Caution

To avoid operation failure, do not energize the A side and B side of 2-position double solenoid valve at the same time.

Light Indication

⚠ Caution

When equipped with indicator light and surge voltage suppressor, the light window turns orange when solenoid a is energized, and it turns green when solenoid b is energized.

<JSY1000 series>

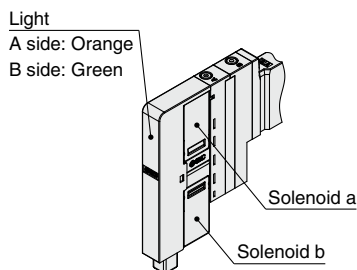

Manifold Indication Symbol

⚠ Caution

The letter "S" is indicated on manifold blocks for the JSY series as shown below. This indication refers to the type of substrate (single wiring) inside the manifold blocks. When there is no symbol, double wiring is used.

When the manifold specification sheet does not include a wiring specification, all stations will be double wiring specification. In this case, single and double solenoid valves can be mounted in any position, but when a single valve is used, there will be an unused control signal. To avoid this, indicate positions of manifold blocks for single wiring specification and double wiring specification on a manifold specification sheet. (Note that double, 3- or 4-position valves cannot be used for manifolds blocks with single wiring specification [S].)

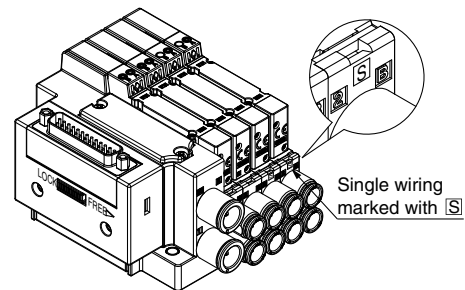

Substrate inside Manifolds

⚠ Caution

The substrate inside of manifolds cannot be taken apart. Attempting to do so may damage parts.

Securing the DIN Rail Mounting Type Manifold

⚠ Caution

1. When the manifold is secured with bolts on a mounting surface, etc., it can be operated just by securing both ends of the DIN rail if the bottom surface of the DIN rail is entirely in contact with the mounting surface when mounted horizontally. However, if it is used with other mounting or with side or reverse mounting, secure the DIN rail with bolts at regular intervals. As a guide, insert bolts in 2 locations for 2-5 stations, 3 locations for 6-10 stations, 4 locations for 11-15 stations, 5 locations for 16-20 stations, and 6 locations for 21-24 stations.
2. When using the manifold with DIN rail in an environment where any vibration or impact is applied to it, the DIN rail itself may be broken. In particular, if the installation surface vibrates when mounting the manifold on the wall or if a load is directly applied to the manifold, the DIN rail may be broken, causing the manifold to drop. When any vibration, impact, or load is applied to the manifold, be sure to use the direct mounting manifold.



JSY1000-E Series Specific Product Precautions 3

Be sure to read this before handling the products. Refer to the back cover for safety instructions. For 3/4-5-port solenoid valve and vacuum equipment precautions, refer to the "Handling Precautions for SMC Products" and the "Operation Manual" on the SMC website: <https://www.smcworld.com>

How to Replace One-touch Fittings

⚠ Caution

By replacing One-touch fittings of manifold base, it is possible to change the connection diameter of the 4(A), 2(B), 1(P), 3/5(E) ports. When replacing the One-touch fittings, remove the clip or the plate before pulling the One-touch fittings off. Mount the One-touch fittings by following the removal procedure in reverse.

Use caution as it may cause air leakage if the clip and the plate are not inserted securely enough when they are switched. Refer to page 33 for part numbers of One-touch fittings.

■ Connector connecting base

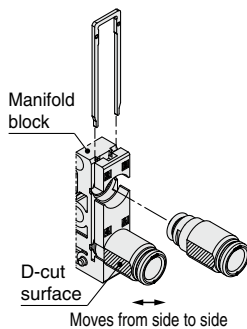

- * In order to replace C2 or C4 with C6 for the JSY1000 series, the manifold block assembly needs to be replaced. Please select the manifold block assembly on page 31.
- * Refer to page 33 for One-touch fitting, clip, and port plate part numbers.

<Assembly method>

· Manifold block

Assemble the fitting so that the D-cut surfaces of the fitting face sideways.

Fitting part no.: KQSY10-C4-X1336 (JSY1000)

Other Tube Brands

⚠ Caution

1. When using other than SMC brand tube, confirm that the following specifications are satisfied with respect to the tube outside diameter tolerance.

- | | |
|----------------------|---------------------------------------|
| 1) Nylon tube | within ± 0.1 mm |
| 2) Soft nylon tube | within ± 0.1 mm |
| 3) Polyurethane tube | within $+0.15$ mm
within -0.2 mm |

Do not use tube which do not meet these outside diameter tolerances. It may not be possible to connect them, or they may cause other trouble, such as air leakage or the tube pulling out after connection.

One-touch Fittings

⚠ Caution

■ Tube attachment/detachment for One-touch fittings

1) Tube attachment

1. Take a tube having no flaws on its periphery and cut it off at a right angle. When cutting the tube, use tube cutters TK-1, 2, or 3. Do not use pliers, nippers, scissors, etc. If cutting is done with tools other than tube cutters, the tube may be cut diagonally or become flattened, etc., making a secure installation impossible, and causing problems such as the tube pulling out after installation or air leakage. Allow some extra length in the tube.
2. Grasp the tube and push it in slowly, inserting it securely all the way into the fitting.
3. After inserting the tube, pull on it lightly to confirm that it will not come out. If it is not installed securely all the way into the fitting, this can cause problems such as air leakage or the tube pulling out.

2) Tube detachment

Use the release tool when the removal of tube is difficult due to the tube size. Refer to page 33 for releasing tools.

1. Push in the release button sufficiently, pushing its collar equally around the circumference.
2. Pull out the tube while holding down the release button so that it does not come out. If the release button is not pressed down sufficiently, there will be increased bite on the tube and it will become more difficult to pull it out.
3. When the removed tube is to be used again, cut off the portion which has been chewed before reusing it. If the chewed portion of the tube is used as is, this can cause trouble such as air leakage or difficulty in removing the tube.

Installation

⚠ Caution

Even though the inlet pressure is within the operating pressure range, when the piping diameter is restricted due to size reduction of supply port (P), the flow will be insufficient. In this case, the valve does not switch completely and the cylinder may malfunction.

Chart

Valve

Manifold

Spacer Type
EjectorOperation
Diagrams

JSY1000-E

Manifold
Exploded ViewFittings,
Replacement Parts,
ToolsManifold
Options

Made to Order

EX260

Specific Product
Precautions



JSY1000-E Series Specific Product Precautions 4

Be sure to read this before handling the products. Refer to the back cover for safety instructions. For 3/4/5-port solenoid valve and vacuum equipment precautions, refer to the "Handling Precautions for SMC Products" and the "Operation Manual" on the SMC website: <https://www.smcworld.com>

Spacer Type Ejector to Be Mounted

Design / Selection

⚠ Warning

1. Vacuum adsorption

At the time of vacuum adsorption, be sure to supply a constant supply of vacuum. Failure to do so may result in foreign matter sticking to the adsorption pad or air leakage, causing the workpiece to drop.

2. Ventilation

Provide ventilation when using a vacuum ejector in a confined area, such as in a closed control panel. For example, install a ventilation opening, etc., in order to prevent pressure from increasing inside of the confined area and to release the heat generated by the valve.

3. Mounting the suction filter

This product is not mounted with a suction filter. The vacuum ejector suctions surrounding dust and water droplets during suctioning of the workpiece. Therefore, it is necessary to avoid the entry of the dust and water droplets into the product. We recommend that you separately install a suction filter in the vacuum side piping. If water droplets or others could be suctioned, please consider installation of a drain separator for vacuum or the like.

4. Vacuum holding

Since valves are subject to air leakage, they cannot be used for applications such as holding vacuum in a pressure vessel. SMC can issue no guarantees regarding the maintenance of workpiece adsorption when using check valves. Take separate safety measures to prevent workpieces from dropping in the case of an electrical power outage, etc.

Supply Valve / Release Valve

⚠ Warning

Air leakage

Zero air leakage is not guaranteed for the supply valve or release valve. Be aware that because there is a chance of air and vacuum leakage, the pressure may change if the vacuum (A, B) port side is tightly sealed.

Ejector Exhaust / Exhaust Noise

⚠ Caution

1. Ejector exhaust

The exhaust resistance should be as small as possible to obtain the full ejector performance. There should be no shield around the exhaust slit for silencer exhaust type.

For port exhaust type, ensure that the back pressure does not exceed 5 kPa. Increased back pressure may lead to the reduction of suction flow and delays in the transport cycle time.

Do not operate the ejector or apply pressure to the exhaust port with the exhaust port closed. This increases the pressure in the product and can damage the vacuum ejector.

Ejector Exhaust / Exhaust Noise

⚠ Caution

2. Exhaust noise

When vacuum ejector generates vacuum, noise can be heard from the exhaust port when the standard supply pressure is close to the pressure that generates peak vacuum pressure making vacuum pressure unstable. If the vacuum pressure range is adequate for adsorption, there should not be a problem. If the noise causes a problem or affects the setting of the SI Unit, change the supply pressure slightly to avoid the pressure range of the noise.

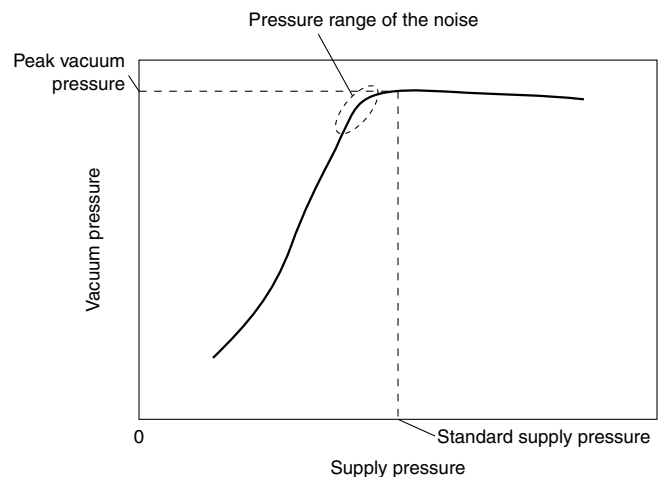

3. Vacuum ejector exhaust air

If solid substances are sucked in through the vacuum (A, B) port, they will be discharged from the exhaust port at a high speed if the exhaust (EXH) port is opened. Therefore, do not look into the exhaust port or direct the exhaust port toward a person when the ejector is operating.

How to Mount the Product

⚠ Caution

1. Do not drop, hit, or apply excessive impact to the product when handling it.

Even if the body looks undamaged, the internal components may be damaged, leading to a malfunction.

2. Load to the body

The product body is made of resin; therefore, do not apply load to the port after mounting. Prevent any kind of operation which generates moment as this may cause reduced performance or damage to the body.



JSY1000-E Series Specific Product Precautions 5

Be sure to read this before handling the products. Refer to the back cover for safety instructions. For 3/4/5-port solenoid valve and vacuum equipment precautions, refer to the “Handling Precautions for SMC Products” and the “Operation Manual” on the SMC website: <https://www.smcworld.com>

Spacer Type Ejector to Be Mounted

Piping

Caution

When piping to the product, be careful not to confuse the vacuum port (A, B port) with the exhaust port of the vacuum ejector. Otherwise this can result in damage or reduced performance. Apply compressed air after confirming that the piping is connected correctly.

If each exhaust piping for the port exhaust ejectors are connected and made into centralized piping, the exhausted air will flow back into the exhaust path which is not operating, and will then be exhausted from the vacuum port. Exhaust individually.

Ejector Air Consumption

Caution

When the ejector is generating vacuum, air is consumed. Therefore, if the air supply capacity is insufficient, the supply pressure may drop. As a guide for sufficient air supply capacity, we recommend that you secure a supply capacity three times or more the air consumption of the ejector.

SI Unit / Fieldbus System

Caution

For details on the SI Unit/Fieldbus system, refer to the Operation Manual on the SMC website.

Chart

Valve

Manifold

Spacer Type
Ejector

Operation
Diagrams

JSY1000-E

Manifold
Exploded View

Fittings,
Replacement Parts,
Tools

Manifold
Options

Made to Order

EX260

Specific Product
Precautions

■ Trademark

EtherCAT® is registered trademark and patented technology, licensed by Beckhoff Automation GmbH, Germany.

Safety Instructions

These safety instructions are intended to prevent hazardous situations and/or equipment damage. These instructions indicate the level of potential hazard with the labels of “**Caution**,” “**Warning**” or “**Danger**.” They are all important notes for safety and must be followed in addition to International Standards (ISO/IEC)*1), and other safety regulations.

 **Caution:** **Caution** indicates a hazard with a low level of risk which, if not avoided, could result in minor or moderate injury.

 **Warning:** **Warning** indicates a hazard with a medium level of risk which, if not avoided, could result in death or serious injury.

 **Danger :** **Danger** indicates a hazard with a high level of risk which, if not avoided, will result in death or serious injury.

*1) ISO 4414: Pneumatic fluid power – General rules relating to systems.
ISO 4413: Hydraulic fluid power – General rules relating to systems.
IEC 60204-1: Safety of machinery – Electrical equipment of machines.
(Part 1: General requirements)
ISO 10218-1: Manipulating industrial robots – Safety.
etc.

Warning

1. The compatibility of the product is the responsibility of the person who designs the equipment or decides its specifications.

Since the product specified here is used under various operating conditions, its compatibility with specific equipment must be decided by the person who designs the equipment or decides its specifications based on necessary analysis and test results. The expected performance and safety assurance of the equipment will be the responsibility of the person who has determined its compatibility with the product. This person should also continuously review all specifications of the product referring to its latest catalog information, with a view to giving due consideration to any possibility of equipment failure when configuring the equipment.

2. Only personnel with appropriate training should operate machinery and equipment.

The product specified here may become unsafe if handled incorrectly. The assembly, operation and maintenance of machines or equipment including our products must be performed by an operator who is appropriately trained and experienced.

3. Do not service or attempt to remove product and machinery/equipment until safety is confirmed.

1. The inspection and maintenance of machinery/equipment should only be performed after measures to prevent falling or runaway of the driven objects have been confirmed.
2. When the product is to be removed, confirm that the safety measures as mentioned above are implemented and the power from any appropriate source is cut, and read and understand the specific product precautions of all relevant products carefully.
3. Before machinery/equipment is restarted, take measures to prevent unexpected operation and malfunction.

4. Contact SMC beforehand and take special consideration of safety measures if the product is to be used in any of the following conditions.

1. Conditions and environments outside of the given specifications, or use outdoors or in a place exposed to direct sunlight.
2. Installation on equipment in conjunction with atomic energy, railways, air navigation, space, shipping, vehicles, military, medical treatment, combustion and recreation, or equipment in contact with food and beverages, emergency stop circuits, clutch and brake circuits in press applications, safety equipment or other applications unsuitable for the standard specifications described in the product catalog.
3. An application which could have negative effects on people, property, or animals requiring special safety analysis.
4. Use in an interlock circuit, which requires the provision of double interlock for possible failure by using a mechanical protective function, and periodical checks to confirm proper operation.

Caution

1. The product is provided for use in manufacturing industries.

The product herein described is basically provided for peaceful use in manufacturing industries.
If considering using the product in other industries, consult SMC beforehand and exchange specifications or a contract if necessary.
If anything is unclear, contact your nearest sales branch.

Limited warranty and Disclaimer/ Compliance Requirements

The product used is subject to the following “Limited warranty and Disclaimer” and “Compliance Requirements”.

Read and accept them before using the product.

Limited warranty and Disclaimer

1. The warranty period of the product is 1 year in service or 1.5 years after the product is delivered, whichever is first.*2)
Also, the product may have specified durability, running distance or replacement parts. Please consult your nearest sales branch.
2. For any failure or damage reported within the warranty period which is clearly our responsibility, a replacement product or necessary parts will be provided.
This limited warranty applies only to our product independently, and not to any other damage incurred due to the failure of the product.
3. Prior to using SMC products, please read and understand the warranty terms and disclaimers noted in the specified catalog for the particular products.

*2) Vacuum pads are excluded from this 1 year warranty.

A vacuum pad is a consumable part, so it is warranted for a year after it is delivered.
Also, even within the warranty period, the wear of a product due to the use of the vacuum pad or failure due to the deterioration of rubber material are not covered by the limited warranty.

Compliance Requirements

1. The use of SMC products with production equipment for the manufacture of weapons of mass destruction (WMD) or any other weapon is strictly prohibited.
2. The exports of SMC products or technology from one country to another are governed by the relevant security laws and regulations of the countries involved in the transaction. Prior to the shipment of a SMC product to another country, assure that all local rules governing that export are known and followed.

Caution

SMC products are not intended for use as instruments for legal metrology.

Measurement instruments that SMC manufactures or sells have not been qualified by type approval tests relevant to the metrology (measurement) laws of each country. Therefore, SMC products cannot be used for business or certification ordained by the metrology (measurement) laws of each country.

Safety Instructions

Be sure to read the “Handling Precautions for SMC Products” (M-E03-3) and “Operation Manual” before use.

SMC Corporation

Akihabara UDX 15F,
4-14-1, Sotokanda, Chiyoda-ku, Tokyo 101-0021, JAPAN
Phone: 03-5207-8249 Fax: 03-5298-5362
<https://www.smcworld.com>
© 2023 SMC Corporation All Rights Reserved

Specifications are subject to change without prior notice and any obligation on the part of the manufacturer.

D-G